

Maintenance Manual

VNA Master™

Handheld Vector Network Analyzer plus Spectrum Analyzer

MS2026C

Vector Network Analyzer 5 kHz to 6 GHz

MS2028C

Vector Network Analyzer 5 kHz to 20 GHz

MS2036C

**Vector Network Analyzer 5 kHz to 6 GHz
Spectrum Analyzer 9 kHz to 9 GHz**

MS2038C

**Vector Network Analyzer 5 kHz to 20 GHz
Spectrum Analyzer 9 kHz to 20 GHz**

The Anritsu logo is located in the bottom right corner of the page. It consists of the word "Anritsu" in a bold, sans-serif font. The letter "A" is stylized with a diagonal slash through it.

Safety Symbols

To prevent the risk of personal injury or loss related to equipment malfunction, Anritsu Company uses the following symbols to indicate safety-related information. For your own safety, please read the information carefully *before* operating the equipment.

Symbols Used in Manuals

Danger



This indicates a very dangerous procedure that could result in serious injury or death, and possible loss related to equipment malfunction, if not performed properly.

Warning



This indicates a hazardous procedure that could result in light-to-severe injury or loss related to equipment malfunction, if proper precautions are not taken.

Caution



This indicates a hazardous procedure that could result in loss related to equipment malfunction if proper precautions are not taken.

Safety Symbols Used on Equipment and in Manuals

The following safety symbols are used inside or on the equipment near operation locations to provide information about safety items and operation precautions. Ensure that you clearly understand the meanings of the symbols and take the necessary precautions *before* operating the equipment. Some or all of the following five symbols may or may not be used on all Anritsu equipment. In addition, there may be other labels attached to products that are not shown in the diagrams in this manual.



This indicates a prohibited operation. The prohibited operation is indicated symbolically in or near the barred circle.



This indicates a compulsory safety precaution. The required operation is indicated symbolically in or near the circle.



This indicates a warning or caution. The contents are indicated symbolically in or near the triangle.



This indicates a note. The contents are described in the box.



These indicate that the marked part should be recycled.

For Safety

Warning



Always refer to the operation manual when working near locations at which the alert mark, shown on the left, is attached. If the operation, etc., is performed without heeding the advice in the operation manual, there is a risk of personal injury. In addition, the equipment performance may be reduced.

Moreover, this alert mark is sometimes used with other marks and descriptions indicating other dangers.

Warning

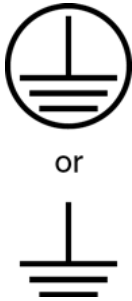

When supplying power to this equipment, connect the accessory 3-pin power cord to a 3-pin grounded power outlet. If a grounded 3-pin outlet is not available, use a conversion adapter and ground the green wire, or connect the frame ground on the rear panel of the equipment to ground. If power is supplied without grounding the equipment, there is a risk of receiving a severe or fatal electric shock.

Warning



This equipment can not be repaired by the operator. Do not attempt to remove the equipment covers or to disassemble internal components. Only qualified service technicians with a knowledge of electrical fire and shock hazards should service this equipment. There are high-voltage parts in this equipment presenting a risk of severe injury or fatal electric shock to untrained personnel. In addition, there is a risk of damage to precision components.

Caution



Electrostatic Discharge (ESD) can damage the highly sensitive circuits in the instrument. ESD is most likely to occur as test devices are being connected to, or disconnected from, the instrument's front and rear panel ports and connectors. You can protect the instrument and test devices by wearing a static-discharge wristband. Alternatively, you can ground yourself to discharge any static charge by touching the outer chassis of the grounded instrument before touching the instrument's front and rear panel ports and connectors. Avoid touching the test port center conductors unless you are properly grounded and have eliminated the possibility of static discharge.

Repair of damage that is found to be caused by electrostatic discharge is not covered under warranty.

Table of Contents

Chapter 1—General Information

1-1	Introduction	1-1
1-2	Description	1-1
	Key Features	1-1
	Frequency Ranges	1-2
	Standard Accessories	1-2
1-3	Related Documents	1-2
1-4	Options	1-3
1-5	Anritsu Customer Service Centers	1-3
1-6	Recommended Test Equipment	1-3
1-7	Recommended Tools and Supplies	1-7
1-8	Replaceable Parts and Assemblies	1-8
1-9	Performance Verification Procedures	1-12

Chapter 2—Vector Network Analyzer Performance Verification

2-1	Introduction	2-1
2-2	Frequency Accuracy	2-1
	Equipment Required	2-1
	Procedure	2-1
2-3	Transmission Dynamic Range	2-3
	Equipment Required	2-3
	Procedure	2-3
2-4	S-Parameter Measurements Verification	2-5
	Equipment Required	2-5
	Special Precautions	2-6
	Procedure	2-6
	If Verification Fails	2-7

Chapter 3—Spectrum Analyzer Performance Verification

3-1	Introduction	3-1
3-2	Residual Spurious Response	3-1
	Equipment Required	3-1
	Procedure	3-1
3-3	Displayed Average Noise level (DANL)	3-4
	Equipment Required	3-4
	Procedure	3-4
3-4	Frequency Accuracy	3-6
	Equipment Required	3-6
	Procedure	3-6
3-5	Single Side Band (SSB) Phase Noise	3-8
	Equipment Required	3-8
	Procedure	3-8

Table of Contents (Continued)

3-6	Spurious Response (Second Harmonic Distortion)	3-11
	Equipment Required	3-11
	Procedure	3-11
3-7	Input Related Spurious (IRS) Signals	3-14
	Equipment Required	3-14
	Procedure	3-14
3-8	Resolution Bandwidth Accuracy	3-18
	Equipment Required	3-18
	Procedure	3-18
3-9	Amplitude Accuracy	3-21
	Equipment Required	3-21
	50 MHz Amplitude Accuracy Verification Procedure	3-21
	Amplitude Accuracy Across Frequency Verification Procedure	3-25
3-10	Third Order Intercept (TOI)	3-27
	Equipment Required	3-27
	Procedure	3-27

Chapter 4—Options Performance Verification

4-1	Introduction	4-1
4-2	Power Monitor (Option 5) Verification	4-1
	Equipment Required	4-1
	Procedure	4-1
4-3	Bias Tee (Option 10) Operational Check	4-4
	Equipment Required	4-4
	Procedure	4-4
	Voltage and Current Test	4-4
	Fault Test	4-5
4-4	GPS (Option 31) Operational Check	4-6
	Equipment Required	4-6
	Procedure	4-6
4-5	Spectrum Analyzer Frequency Accuracy with GPS On	4-8
	Equipment Required	4-8
	Procedure	4-9

Chapter 5—Battery Information and Replacement

5-1	Introduction	5-1
5-2	Replaceable Parts and Assemblies	5-1
5-3	Battery Information	5-1
	Approved Batteries Only	5-1
	Recharging	5-2
	Analyzer Not In Use	5-2
	Physical Handling of Batteries	5-2
	Battery Disposal	5-2
5-4	Battery Pack Removal and Replacement	5-3

Chapter 6—Assembly Removal and Replacement, MS202xC

Table of Contents (Continued)

6-1	Introduction	6-1
6-2	Electrostatic Discharge Prevention	6-1
6-3	Real Time Clock (RTC) Battery	6-1
6-4	Replaceable Parts, Assemblies, and Accessories	6-1
6-5	Front Panel Components for VNA Master MS202xC	6-2
6-6	Main Keypad Bezel for VNA Master MS202xC	6-3
6-7	Main Menu Keypad Bezel for VNA Master MS202xC	6-5
6-8	Internal Anatomy of the VNA Master MS2026C	6-6
	MS2026C View from Top Connector Strip	6-6
	MS2026C View from Bottom	6-7
6-9	Internal Anatomy of the VNA Master MS2028C	6-8
	MS2028C View from Top Connector Strip	6-8
	MS2028C View from Bottom	6-9
6-10	Disassembly Sequence Overview	6-10
	Outside Replacements	6-10
	Inside Replacements	6-10
	Overview of Replaceable Component Parts	6-11
6-11	Replacing Main Keypad Components – 3-61362, 3-71027-3	6-12
	Part Numbers	6-12
	Procedure	6-12
6-12	Replacing Main Menu Keypad Rubber Membrane – 3-61361	6-15
	Part Numbers	6-15
	Procedure	6-15
6-13	Replacing Main Menu Keypad Components	6-17
	Part Numbers	6-17
	Procedure	6-17
6-14	Replacing Hand Strap – 3-61470	6-21
	Part Numbers	6-21
	Procedure	6-21
6-15	Replacing Rotary Knob – 3-61360-2	6-22
	Part Numbers	6-22
	Procedure	6-22
6-16	Opening the Instrument Case	6-23
	Procedure	6-23
	Closing the Case	6-24
6-17	Replacing Power Monitor PCB Assembly, Option 5 – ND67197	6-25
	Part Number	6-25
	Procedure	6-25
	Replacing Case Rear Assembly and Battery	6-27
6-18	Replacing VNA PCB Assembly	6-28
	Part Numbers	6-28
	Removal Procedure	6-28

Table of Contents (Continued)

6-19	Replacing GPS Receiver Module (Option 31) – ND70320	6-35
	Part Numbers	6-35
	Procedure	6-35
6-20	Replacing Rotary Encoder – 3-410-101	6-39
	Part Numbers	6-39
	Procedure	6-39
6-21	Removing Main PCB Assembly	6-42
	Procedure	6-42
6-22	Replacing Main PCB Assembly – ND72084, ND72085	6-45
	Part Numbers	6-45
	Procedure	6-45
6-23	Replacing LCD Display – 3-15-154	6-48
	Part Numbers	6-48
	Procedure	6-48
6-24	Replacing Clear Plastic LCD Protector – 3-61368	6-49
	Part Numbers	6-49
	Procedure	6-49
6-25	Installing Main PCB and Reassembling Instrument	6-50
	Procedure	6-50
6-26	Replacing Fan Assembly – ND70948	6-55
	Part Numbers	6-55
	Procedure	6-55

Chapter 7—Assembly Removal and Replacement, MS203xC

7-1	Introduction	7-1
7-2	Electrostatic Discharge Prevention	7-1
7-3	Real Time Clock (RTC) Battery	7-1
7-4	Replaceable Parts, Assemblies, and Accessories	7-1
7-5	Front Panel Components for VNA Master MS203xC	7-2
7-6	Main Keypad Bezel for VNA Master MS203xC	7-3
7-7	Main Menu Keypad Bezel for VNA Master MS203xC	7-4
7-8	Internal Anatomy of the VNA Master MS2036C	7-5
	MS2036C View from Top Connector Panel	7-5
	MS2036C Connections Front to Back	7-6
7-9	Internal Anatomy of the VNA Master MS2038C	7-7
	MS2038C View from Top Connector Panel	7-7
	MS2038C Connections Front to Back	7-8
	MS203xC Case and Back Screws	7-9
7-10	Disassembly Sequence Overview	7-10
	Outside Replacements	7-10
	Inside Replacements	7-10
	Overview of Replaceable Component Parts	7-11

Table of Contents (Continued)

7-11	Replacing Main Keypad Components – 3-61362, 65027-3	7-12
	Part Numbers	7-12
	Procedure	7-12
	Replacement Options	7-13
7-12	Removing Main Keypad Rubber Membrane	7-14
7-13	Replacing Main Menu Keypad Rubber Membrane – 3-61361	7-16
	Part Numbers	7-16
	Procedure	7-16
7-14	Replacing Main Menu Keypad Components – 3-61361, 61333-3	7-18
	Part Numbers	7-18
	Procedure	7-18
7-15	Replacing Hand Strap – 3-61470	7-22
	Part Numbers	7-22
	Procedure	7-22
7-16	Replacing Rotary Knob – 3-61360-2	7-23
	Part Numbers	7-23
	Procedure	7-23
7-17	Opening the Instrument Case	7-24
	Procedure	7-24
	Closing the Case	7-27
7-18	Replacing SPA Module Assembly	7-28
	Part Numbers	7-28
	Procedure	7-29
7-19	Replacing VNA PCB Assembly	7-33
	Part Numbers	7-33
	Procedure	7-34
7-20	Replacing GPS Receiver Module (Option 31) – ND70320	7-41
	Part Numbers	7-41
	Procedure	7-41
7-21	Replacing Rotary Encoder – 3-410-101	7-45
	Part Numbers	7-45
	Procedure	7-45
7-22	Removing Main PCB Assembly	7-50
	Procedure	7-51
7-23	Replacing Main PCB Assembly – ND72086, ND72087	7-56
	Part Numbers	7-56
	Procedure	7-56
7-24	Replacing LCD Display – 3-15-154	7-59
	Part Numbers	7-59
	Procedure	7-59
7-25	Replacing Clear Plastic LCD Protector – 3-61368	7-61
	Part Numbers	7-61
	Procedure	7-61

Table of Contents (Continued)

7-26	Installing Main PCB and Reassembling Instrument	7-62
	Procedure	7-62
7-27	Replacing Fan Assembly – ND70948	7-72
	Part Numbers	7-72
	Procedure	7-72

Chapter 8—Troubleshooting

8-1	Introduction	8-1
8-2	Turn-on Problems	8-1
	Unit Cannot Boot Up (Battery Powered)	8-1
	Unit Cannot Boot Up (AC Powered)	8-1
	Unit Cannot Complete Boot-Up	8-1
	Unit Boots with No Display	8-1
	Boot-up Self Test Fails	8-2
8-3	Operating Problems	8-2
	IF Out of Range Message (Vector Network Analyzer Mode)	8-2
	Lock Error Message	8-2
	Inaccurate Amplitude Measurements (Spectrum Analyzer Mode)	8-2
	Option 5, Power Monitor Problems	8-2
	Option 10, VNA Bias Tee Problems	8-2
	Option 31, GPS Problems	8-2

Appendix A—Test Records

A-1	Introduction	A-1
	Instrument Information	A-2
A-2	MS2026C VNA Master Test Record	A-2
	VNA Frequency Accuracy – MS2026C	A-2
	VNA Transmission Dynamic Range – MS2026C	A-2
	VNA S-Parameter Measurements Verification – MS2026C	A-2
	Power Monitor Measurement Accuracy (For instruments with Option 5) – MS2026C	A-2
A-3	MS2028C VNA Master Test Record	A-3
	VNA Frequency Accuracy – MS2028C	A-3
	VNA Transmission Dynamic Range – MS2028C	A-3
	VNA S-Parameter Measurements Verification – MS2028C	A-3
	Power Monitor Measurement Accuracy (For instruments with Option 5) – MS2028C	A-3

Table of Contents (Continued)

A-4	MS2036C VNA Master Test Record	A-4
	VNA Frequency Accuracy – MS2036C	A-4
	VNA Transmission Dynamic Range – MS2036C	A-4
	VNA S-Parameter Measurements Verification – MS2036C	A-4
	Spectrum Analyzer Residual Spurious Response – MS2036C	A-5
	Spectrum Analyzer Displayed Average Noise Level (DANL) – MS2036C	A-6
	Spectrum Analyzer Frequency Accuracy – MS2036C	A-6
	Spectrum Analyzer Frequency Accuracy (Option 31, GPS) – MS2036C	A-6
	Spectrum Analyzer Single Side Band (SSB) Phase Noise – MS2036C	A-7
	Spectrum Analyzer Spurious Response (Second Harmonic Distortion) – MS2036C	A-7
	Spectrum Analyzer Input Related Spurious (IRS) Signals – MS2036C	A-7
	Spectrum Analyzer Resolution Bandwidth Accuracy – MS2036C	A-8
	Spectrum Analyzer Amplitude Accuracy – MS2036C	A-9
	Spectrum Analyzer Third Order Intercept – MS2036C	A-13
A-5	MS2038C VNA Master Test Record	A-14
	VNA Frequency Accuracy – MS2038C	A-14
	VNA Transmission Dynamic Range – MS2038C	A-14
	VNA S-Parameter Measurements Verification – MS2038C	A-14
	Spectrum Analyzer Residual Spurious Response – MS2038C	A-15
	Spectrum Analyzer Displayed Average Noise Level (DANL) – MS2038C	A-16
	Spectrum Analyzer Frequency Accuracy – MS2038C	A-17
	Spectrum Analyzer Frequency Accuracy (Option 31, GPS) – MS2038C	A-17
	Spectrum Analyzer Single Side Band (SSB) Phase Noise – MS2038C	A-17
	Spectrum Analyzer Spurious Response (Second Harmonic Distortion) – MS2038C	A-17
	Spectrum Analyzer Input Related Spurious (IRS) Signals – MS2038C	A-18
	Spectrum Analyzer Resolution Bandwidth Accuracy – MS2038C	A-18
	Spectrum Analyzer Amplitude Accuracy – MS2038C	A-19
	Spectrum Analyzer Third Order Intercept – MS2038C	A-27

Appendix B—Test Fixture Schematics

B-1	Introduction	B-1
B-2	T2904 Test Fixture Schematic	B-1
B-3	T3377 Test Fixture Schematic	B-2
B-4	T3536 Test Fixture Schematic	B-3

Index

Table of Contents (Continued)

Chapter 1 — General Information

1-1 Introduction

This manual provides service and maintenance information for the Anritsu MS2026C, MS2028C, MS2036C and MS2038C models of the handheld VNA Master. The information includes product descriptions, replaceable parts information, performance verification procedures, parts removal and replacement procedures, and troubleshooting information.

Throughout this manual, the following terms apply:

- VNA Master refers to the MS2026C, MS2028C, MS2036C, or MS2038C
- MS202xC refers to either the MS2026C or MS2028C
- MS203xC refers to either the MS2036C or MS2038C

1-2 Description

The MS202xC VNA Master is a broadband Vector Network Analyzer that offers true 2-Port 12-term error correction calibration in a handheld, battery-operated, rugged multi-function instrument.

The MS203xC VNA Master is portable and handheld with integrated vector network analysis and spectrum analysis capabilities in a single instrument. It offers the same vector network analysis capability as the MS202xC VNA Master as well as spectrum analysis capability with performance and features that rival bench-top alternatives for simplifying spectrum monitoring, interference analysis, and other general purpose signal measurements in the field.

Key Features

Vector Network Analyzer

- Frequency coverage from 5 kHz to 20 GHz
- Full-reversing 2-port Vector Network Analyzer architecture
- Dynamic Range of 100 dB to 3 GHz, 90 dB to 6 GHz, and 85 dB to 20 GHz
- IF Bandwidth selections of 10 Hz to 100 kHz
- Arbitrary data points of 2 to 4001
- Frequency resolution of 1 Hz to 375 MHz, 10 Hz to 6 GHz, and 100 Hz to 20 GHz
- Available options for Vector Voltmeter, Integrated Bias Tee, Differential S-parameters, and Distance Domain

Spectrum Analyzer

- Frequency coverage from 9 kHz to 20 GHz
- Dynamic Range of >104 dB
- Displayed Average Noise Level (with preamp) of -160 dBm in 1 Hz RBW
- Dynamic Range of >104 dB in 1 Hz RBW
- SSB Phase Noise of < -100 dBc/Hz at 10 kHz offset
- Resolution Bandwidth (RBW) selections of 1 Hz to 10 MHz
- Built-in signal standards and channel numbers
- Available options for Channel Scanner, and Interference Analyzer

Frequency Ranges

Table 1-1. Frequency Range Values

Instrument	Frequency Ranges
MS2026C	VNA, 5 kHz to 6 GHz, N Connectors
MS2028C	VNA, 5 kHz to 20 GHz, N Connectors or K Connectors
MS2036C	VNA, 5 kHz to 6 GHz, N Connectors SPA, 9 kHz to 9 GHz, N Connectors
MS2038C	VNA, 5 kHz to 20 GHz, N Connectors or K Connectors SPA, 9 kHz to 20 GHz, N Connectors or K Connectors

Standard Accessories

Table 1-2. Part Numbers for Standard Accessories

Anritsu Part Number	Description
10580-00305	MS2026C/MS2028C and MS2036C/MS2038C User Guide
2300-498	Master Software Tools CD ROM
633-44	Rechargeable battery, Lithium-Ion
40-168-R	AC to DC Power Adapter
806-141-R	Automotive 12 Volt DC Adapter
3-2000-1498	USB A-mini B Cable, 3 meters (10 feet)
2000-1371-R	Cat 5 Ethernet Cable
3-806-152	Cat 5 Ethernet Crossover Cable
2000-1520-R	2 GB USB Memory Drive
65729	Soft Carrying Case for MS202xC VNA Master
65681	Soft Carrying Case for MS203xC VNA Master

1-3 Related Documents

Other documents are available for the MS2026C, MS2028C, MS2036C and MS2038C at the Anritsu web site at: www.anritsu.com

- VNA Master MS2026C/MS2028C and MS2036C/MS2038C User Guide – PN 10580-00305
- VNA Master MS2026C/MS2028C and MS2036C/MS2038C Programming Manual – PN 10580-00306

1-4 Options

Table 1-3. Option Numbers and Descriptions

Option Number	Option Description
Option 2	Time Domain Analysis (Includes Distant Domain functionality)
Option 5	Power Monitor (requires external detector, MS2026C and MS2028C Only)
Option 7	Secure Data Operation
Option 10	Built-in Variable Bias-Tee (+12 V to +32 V in 0.1 V steps)
Option 11	K(f) Test Port Connectors (MS2028C and MS2038C Only)
Option 15	Vector Voltmeter
Option 19	High Accuracy Power Meter (requires external USB Sensor)
Option 25	Interference Analysis (MS2036C and MS2038C Only)
Option 27	Channel Scanner (MS2036C and MS2038C Only)
Option 31	GPS Receiver (requires GPS antenna, 2000-1528-R, sold separately)
Option 77	Balanced/Differential S-parameters, 1-Port
Option 501	Distance Domain (Do not order concurrently with Option 2)

1-5 Anritsu Customer Service Centers

For the latest service and sales information in your area, please visit the following URL:

<http://www.anritsu.com/contact.asp>

Choose a country for regional contact information.

1-6 Recommended Test Equipment

The following test equipment is recommended for use in testing and maintaining the VNA Master.

Table 1-4. Recommended Test Equipment for Vector Network Analyzer Verification (1 of 2)

Equipment	Critical Specification	Recommended Manufacturer/Model
Frequency Counter	Frequency: 2 GHz to 3 GHz	Anritsu Model MF2412B or MF2412C
Frequency Reference	Frequency: 10 MHz	Symmetricom Model RubiSource T&M
Open/Short/Load	Frequency: DC to 18 GHz Connector: N(m)	Anritsu Model OSLN50
Open/Short/Load	Frequency: DC to 18 GHz Connector: N(f)	Anritsu Model OSLNF50
RF Coaxial Cable	Frequency: DC to 18 GHz Impedance: 50 ohm Connector: N(m) to N(m)	Anritsu Model 3670NN50-2
Verification Kit	Connector: N Type	Anritsu Model SC7858 (Includes 2300-533-R software)
Torque Wrench	3/4 in. (0.75 in.) Open End Wrench 12 lbf·in (1.35 N·m)	Anritsu Model 01-200

Table 1-4. Recommended Test Equipment for Vector Network Analyzer Verification (2 of 2)

Equipment	Critical Specification	Recommended Manufacturer/Model
Open/Short/Load (for Option 11)	Frequency: DC to 20 GHz Connector: K(m)	Anritsu Model OSLK50
Open/Short/Load (for Option 11)	Frequency: DC to 20 GHz Connector: K(f)	Anritsu Model OSLKF50
RF Coaxial Cable (for Option 11)	Frequency: DC to 40 GHz Impedance: 50 ohm Connector: K(f) to K(m)	Anritsu Model 3670K50-2
Verification Kit (for Option 11)	Connector: K Type	Anritsu Model SC7859 (includes 2300-533-R software)
Adapter (for Option 11)	Frequency: DC to 40 GHz Connector: K(m) to K(m)	Anritsu Model 33KK50B
Adapter (for Option 11)	Frequency: DC to 18 GHz Connector: N(f) to K(m)	Anritsu Model 34NFK50
Torque Wrench (for Option 11)	5/16 in. (0.325 in.) Open End Wrench 8 lbf·in (0.90 N·m)	Anritsu Model 01-201
Personal Computer	Operating System: Windows XP Interface: Ethernet, RJ-48 Software: National Instruments VISA version 4.4.1 or later	Any
System Verification Software		Anritsu Part Number 2300-533-R
Test Software		Anritsu Part Number 2300-535

Table 1-5. Recommended Test Equipment for Spectrum Analyzer Verification - For MS203xC Only (1 of 2)

Equipment	Critical Specification	Recommended Manufacturer/Model
Frequency Reference	Frequency: 10 MHz	Symmetricom Model RubiSource T&M
Synthesized Signal Generator	Frequency: 0.1 Hz to 20 GHz Power Output: +16 dBm Step attenuator installed	Anritsu Model MG3692B or MG3692C with Options 2A, 4 and 22 (Quantity 2)
Power Meter	Power Range: (-70 to +20) dBm	Anritsu Model ML2438A
Power Sensor	Frequency: 100 kHz to 18 GHz Power Range: -67 to +20 dBm	Anritsu Model SC7400 (Quantity 2)
Power Sensor	Frequency: 10 MHz to 18 GHz Power Range: -67 to +20 dBm	Anritsu Model MA2442D
RF Coaxial Cable	Frequency: DC to 18 GHz Impedance: 50 ohm Connector: N(m) to N(m)	Anritsu Model 15NN50-1.0B (Quantity 2)
Power Splitter	Frequency: DC to 18 GHz Connector: N(f)	Aeroflex/Weinschel Model 1870A
Fixed Attenuator	Frequency: DC to 18 GHz Attenuation: 10 dB	Aeroflex/Weinschel Model 44-10
Fixed Attenuator	Frequency: DC to 18 GHz Attenuation: 2 dB	Aeroflex/Weinschel Model 44-2 (Quantity 2)
Fixed Attenuator	Frequency: DC to 18 GHz Attenuation: 6 dB	Aeroflex/Weinschel Model 44-6 (Quantity 2)
Fixed Attenuator	Frequency: DC to 18 GHz Attenuation: 20 dB	Aeroflex/Weinschel Model 44-20 (Quantity 2)
Adapter	Frequency: DC to 18 GHz Connector: K(m) to N(f)	Anritsu Model 34RKNF50 (Quantity 2)
Adapter	Frequency: DC to 18 GHz Connector: N(m) to N(m)	Anritsu Model 34NN50A
Tee Adapter	BNC(m) to BNC(f)/BNC(f)	Anritsu Part Number 3-2600-2
Low Pass Filter	Frequency: 50 MHz Connector: N(m) to N(f)	Anritsu Part Number 1030-96
Termination	Frequency: DC to 18 GHz Impedance: 50 ohm Connector: N(m)	Anritsu Model 28N50-2
Coaxial Cable	Impedance: 50 ohm Connector: BNC(m) to BNC(m)	Anritsu part number 2000-1627-R (Quantity 3)
Power Sensor (for Option 11)	Frequency: 100 kHz to 40 GHz Power Range: -67 to +20 dBm	Anritsu Model SC7413 (Quantity 2)
RF Coaxial Cable (for Option 11)	Frequency: DC to 20 GHz Connector: K(m) to K(f)	Anritsu Model 15KKF50-1.0A
Power Splitter (for Option 11)	Frequency: DC to 40 GHz Connector: K Type	Anritsu Model K241C
Fixed Attenuator (for Option 11)	Frequency: DC to 40 GHz Connector: K Type	Anritsu Model 41KC-10

Table 1-5. Recommended Test Equipment for Spectrum Analyzer Verification - For MS203xC Only (2 of 2)

Equipment	Critical Specification	Recommended Manufacturer/Model
Adapter (for Option 11)	Frequency: DC to 18 GHz Connector: N(f) to K(m)	Anritsu Model 34NFK50
Adapter (for Option 11)	Frequency: DC to 40 GHz Connector: K(m) to K(m)	Anritsu Model 33KK50B
Termination (for Option 11)	Frequency: DC to 40 GHz Impedance: 50 ohm Connector: K(m)	Anritsu Model 28K50

Table 1-6. Recommended Test Equipment for Options Verification

Equipment	Critical Specification	Recommended Manufacturer/Model
Synthesized Signal Generator (for Option 5)	Frequency: 1 GHz Power Level: -40 dBm to +13 dBm	Anritsu Model MG3692B or MG3692C with Options 2A and 4 (or 5)
RF Detector (for Option 5)	Frequency: 10 MHz to 20 GHz	Anritsu Model 560-7N50B
Adapter (for Option 5)	Frequency: DC to 40 GHz Connector: K(m) to N(f)	Anritsu Model 34RKNF50
Power Meter (for Option 5)	Power Range: (-70 to +20) dBm	Anritsu Dual Channel Model ML2438A
Power Sensor (for Option 5)	Frequency: 10 MHz to 18 GHz, Range: -67 to +20 dB	Anritsu Model MA2442D
Power Splitter (for Option 5)	Frequency: DC to 18 GHz	Aeroflex/Weinschel Model 1870A
Load Test Fixture (for Option 10)	Resistance: 40 ohm Power: 5 Watts	Anritsu Model T2904
Load Test Fixture (for Option 10)	Resistance: 105 ohm Power: 1 watt	Anritsu Model T3377
Load Test Fixture (for Option 10)	Resistance: 78 ohm Power: 20 Watts	Anritsu Model T3536
GPS Antenna (for Option 31)	Connector: SMA male Bias: 3 V or 5 V	Anritsu Part Number 2000-1528-R or Trimble Part Number 57861-00 [TNC(f) to SMA(m) Adapter required]
Adapter (for Option 31)	Connector: SMA(m) to BNC(f)	Pomona Part Number 4290
Terminator (for Option 31)	Connector: BNC(m) Impedance: 93 ohm	Amphenol Part Number B1004A1-ND3G-93R-0.05-1W

1-7 Recommended Tools and Supplies

- Castellated Socket with 1/4 inch hex drive – For Castellated (Slotted) BNC Connector Dress Nuts
 - Anritsu Part Number T1451
- Hex driver handle – For Anritsu Part Number T1451
- Medium Phillips-head Screwdriver
- 7.5 lbf ·in (0.85 N ·m) Torque Limiting Phillips-head Screwdriver
Felo brand Series Nm adjustable torque screwdriver set, 0.6 Nm to 1.5 Nm
- Small Flat Blade Screwdriver, with tip width of less than 3.5 mm – For Front Panel Keypad Bezels
- Small square of rubber or similar non-scratch material approximately 25 mm x 25 mm (1 inch x 1 inch) – For Front Panel Keypad Bezels
- 5.5 mm Angled-Head Open End Wrench
- 5/16 inch (~8 mm) Open End Wrench, 2 each recommended – For SMA Connectors
- 5/16 inch and 8 lbf ·in (0.9 N ·m) Open End Torque Wrench – For Option 11
 - Anritsu Model 01-201
- 7/16 inch (~12 mm) Nut Driver – For Rotary Encoder
- 3/4 inch and 12 lbf ·in (1.35 N ·m) Open End Torque Wrench, Anritsu Model 01-200
- Needle-Nose Pliers
- Small Cable Ties
- Scraper Tool – For removing RTV from connectors
- Room Temperature Vulcanizing (RTV) Silicon Sealant – For Keypad Flex PCB Replacement
Anritsu Part Number 3-783-1102
- Approved cleaning supplies – For LCD Display, Clear Plastic LCD Protector, and instrument Case

1-8 Replaceable Parts and Assemblies

To ensure that the correct options are provided on the replacement assembly when ordering a VNA Module Assembly, a Main PCB Assembly, or a SPA Assembly, all installed instrument options must be declared on the order.

The installed options are listed on a label on the top of the MS202xC and MS203xC. They can also be viewed in the System Status display.

Table 1-7 summarizes the available replaceable parts and assemblies with links to [Chapter 6, “Assembly Removal and Replacement, MS202xC”](#) detailed procedures

Table 1-7. Replaceable Parts and Assemblies (1 of 4)

Part Number	Description
ND72084	Main PCB Assembly for MS2026C instruments – VNA Module not included – LCD Display not included – Section 6-22 “Replacing Main PCB Assembly – ND72084, ND72085” on page 6-45
ND72085	Main PCB Assembly for MS2028C instruments – VNA Module not included – LCD Display not included – Section 6-22 “Replacing Main PCB Assembly – ND72084, ND72085” on page 6-45
ND72086	Main PCB Assembly for MS2036C instruments – VNA Module not included – SPA Assembly not included – LCD Display not included – Section 7-22 “Removing Main PCB Assembly” on page 7-50
ND72087	Main PCB Assembly for MS2038C instruments – VNA Module not included – SPA Assembly not included – LCD Display not included – Section 7-22 “Removing Main PCB Assembly” on page 7-50
ND72088	VNA Module Assembly with N(f) connectors for MS2026C Instruments – Section 6-18 “Replacing VNA PCB Assembly” on page 6-28
ND72089	VNA Module Assembly with N(f) connectors for MS2028C Instruments – For MS2028C instruments equipped with standard N(f) Test Ports – Section 6-18 “Replacing VNA PCB Assembly” on page 6-28
ND72090	VNA Module Assembly with K(f) connectors for MS2028C Instruments – For MS2028C instruments equipped with Option 11 K(f) Test Ports – Section 6-18 “Replacing VNA PCB Assembly” on page 6-28
ND72091	VNA Module Assembly with N(f) connectors for MS2036C Instruments – Section 7-19 “Replacing VNA PCB Assembly” on page 7-33
ND72092	VNA Module Assembly with N(f) connectors for MS2038C Instruments – For MS2038C instruments equipped with standard N(f) Test Ports – Section 7-19 “Replacing VNA PCB Assembly” on page 7-33
ND72093	VNA Module Assembly with K(f) connectors for MS2038C Instruments – For MS2038C instruments equipped with Option 11 K(f) Test Ports – Section 7-19 “Replacing VNA PCB Assembly” on page 7-33
ND72094	SPA Assembly with N(f) connector for MS2036C Instruments – Section 7-18 “Replacing SPA Module Assembly” on page 7-28
ND72095	SPA Assembly with N(f) connector for MS2038C Instruments – For MS2038C instruments equipped with standard N(f) Test Ports – Section 7-18 “Replacing SPA Module Assembly” on page 7-28

Table 1-7. Replaceable Parts and Assemblies (2 of 4)

Part Number	Description
MD72096	SPA Assembly with K(f) connector for MS2038C Instruments – For MS2038C instruments equipped with Option 11 K(f) Test Ports – Section 7-18 “Replacing SPA Module Assembly” on page 7-28
ND67197	Power Monitor PCB Assembly, Option 5 – For MS2026C and MS2028C instruments equipped with Option 5 Power Monitor – Section 6-18 “Replacing VNA PCB Assembly” on page 6-28
ND70320	GPS Receiver Module, Option 31 – Does not include GPS Antenna 2000-1528-R – For MS2026C and MS2028C instruments equipped with Option 31 GPS Receiver – Section 6-19 “Replacing GPS Receiver Module (Option 31) – ND70320” on page 6-35 – For MS2036C and MS2038C instruments equipped with Option 31 GPS Receiver – Section 7-20 “Replacing GPS Receiver Module (Option 31) – ND70320” on page 7-41
3-15-154	LCD Display – For all MS202xC and MS203xC instruments – Section 6-23 “Replacing LCD Display – 3-15-154” on page 6-48 – Section 7-24 “Replacing LCD Display – 3-15-154” on page 7-59
3-61368	Clear Plastic LCD Protector – For all MS202xC and MS203xC instruments – Section 6-24 “Replacing Clear Plastic LCD Protector – 3-61368” on page 6-49 – Section 7-25 “Replacing Clear Plastic LCD Protector – 3-61368” on page 7-61
3-61362	Main Keypad Rubber Membrane – For all MS202xC and MS203xC instruments – Section 6-11 “Replacing Main Keypad Components – 3-61362, 3-71027-3” on page 6-12 – Section 7-11 “Replacing Main Keypad Components – 3-61362, 65027-3” on page 7-12
3-71027-3	Main Keypad PCB – For all MS202xC and MS203xC instruments – Section 6-11 “Replacing Main Keypad Components – 3-61362, 3-71027-3” on page 6-12 – Section 7-11 “Replacing Main Keypad Components – 3-61362, 65027-3” on page 7-12
3-61363-1	Main Keypad Plastic Bezel – For all MS202xC and MS203xC instruments – Section 6-11 “Replacing Main Keypad Components – 3-61362, 3-71027-3” on page 6-12 – Section 7-11 “Replacing Main Keypad Components – 3-61362, 65027-3” on page 7-12
3-61361	Main Menu Keypad Rubber Membrane – For all MS202xC and MS203xC instruments – Section 6-12 “Replacing Main Menu Keypad Rubber Membrane – 3-61361” on page 6-15 – Section 7-14 “Replacing Main Menu Keypad Components – 3-61361, 61333-3” on page 7-18
3-71030-3	Main Menu Keypad Flex PCB – For all MS202xC and MS203xC instruments – Section 6-13 “Replacing Main Menu Keypad Components” on page 6-17 – Section 7-14 “Replacing Main Menu Keypad Components – 3-61361, 61333-3” on page 7-18
3-61378-1	Main Menu Keypad Plastic Bezel – For all MS202xC and MS203xC instruments – Section 6-13 “Replacing Main Menu Keypad Components” on page 6-17 – Section 7-14 “Replacing Main Menu Keypad Components – 3-61361, 61333-3” on page 7-18
3-410-101	Rotary Encoder – For all MS202xC and MS203xC instruments – Does not include the Rotary Knob 3-61360-2 – Section 6-20 “Replacing Rotary Encoder – 3-410-101” on page 6-39 – Section 7-21 “Replacing Rotary Encoder – 3-410-101” on page 7-45

Table 1-7. Replaceable Parts and Assemblies (3 of 4)

Part Number	Description
3-61360-2	Encoder Rotary Knob (excluding encoder) – For all MS202xC and MS203xC instruments – Does not include the Rotary Encoder 3-410-101 – Section 6-15 “Replacing Rotary Knob – 3-61360-2” on page 6-22 – Section 7-16 “Replacing Rotary Knob – 3-61360-2” on page 7-23
ND70948	Fan Assembly – For all MS202xC and MS203xC instruments – Section 6-26 “Replacing Fan Assembly – ND70948” on page 6-55 – Section 7-27 “Replacing Fan Assembly – ND70948” on page 7-72
790-625	Speaker – For all MS202xC and MS203xC instruments The replacement procedure is not described separately. The speaker is attached to the Main Keypad PCB. Refer to: – Section 6-11 “Replacing Main Keypad Components – 3-61362, 3-71027-3” on page 6-12 – Section 7-11 “Replacing Main Keypad Components – 3-61362, 65027-3” on page 7-12
3-61470	Hand Strap – For all MS202xC and MS203xC instruments – Section 6-14 “Replacing Hand Strap – 3-61470” on page 6-21 – Section 7-15 “Replacing Hand Strap – 3-61470” on page 7-22
3-61571	Hand Strap Ring Holder – For all MS202xC and MS203xC instruments – Two each per instrument – The replacement procedure is not described separately. Refer to: – Section 6-14 “Replacing Hand Strap – 3-61470” on page 6-21 – Section 7-15 “Replacing Hand Strap – 3-61470” on page 7-22
3-905-2685	Hand Strap Ring Holder Mounting Screw – For all MS202xC and MS203xC instruments – Two each per instrument – The replacement procedure is not described separately. Refer to: – Section 6-14 “Replacing Hand Strap – 3-61470” on page 6-21 – Section 7-15 “Replacing Hand Strap – 3-61470” on page 7-22
3-68100-2	Top Case – For all MS202xC and MS203xC instruments – Does not include Model ID Label and keypad items
ND68809	Bottom Case with Tilt Bail – For all MS202xC instruments
ND71717	Bottom Case with Tilt Bail – For all MS203xC instruments
3-68110	Model ID Label for MS2026C instruments
3-68111	Model ID Label for MS2028C instruments
3-68168	Model ID Label for MS2036C instruments
3-68182	Model ID Label for MS2038C instruments
61379-2	Battery Door – For all MS202xC instruments – Refer to Chapter 5 for replacement of the battery door

Table 1-7. Replaceable Parts and Assemblies (4 of 4)

Part Number	Description
3-67151-2	Battery Door – For all MS203xC instruments – Refer to Chapter 5 for replacement of the battery door
633-44	Rechargeable Battery, Lithium-Ion – For all MS202xC and MS203xC instruments
3-806-195	Battery Connector Harness – For all MS202xC and MS203xC instruments – The replacement procedure is not described separately. Refer to: – Figure 6-14 on page 6-30 , Figure 6-16 on page 6-32 , or Figure 7-21 on page 7-37
40-168-R	AC to DC Power Adapter – For all MS202xC and MS203xC instruments
65729	Soft Carrying Case – For all MS202xC instruments
65681	Soft Carrying Case – For all MS203xC instruments
806-141	Automotive 12 Volt DC Adapter – For all MS202xC and MS203xC instruments
3-2000-1498	USB Type 2 A to Mini B Cable, 3 meters (10 feet) – For all MS202xC and MS203xC instruments
2000-1371-R	Category 5 (Cat5) Ethernet Cable – For all MS202xC and MS203xC instruments
3-806-152	Category 5 (Cat5) Crossover Cable – For all MS202xC and MS203xC instruments

1-9 Performance Verification Procedures

Performance verification procedures are in the following Chapters:

- Chapter 2, “Vector Network Analyzer Performance Verification”
- Chapter 3, “Spectrum Analyzer Performance Verification”
- Chapter 4, “Options Performance Verification”

Refer to [Table 1-8](#) for the list of performance verification procedures that are required for each instrument model. Perform all of the procedures with an “x” in the **Std** column. Also perform the procedures with a “x” in the **Opt 5**, **Opt 10** and **Opt 31** columns when these options are installed in the instrument.

Table 1-8. Required Performance Verification Procedures for each model of VNA Master (1 of 2)

Model	Performance Verification Procedure	Std	Opt 5	Opt 10	Opt 31	Procedure Sections
MS2026C	VNA Frequency Accuracy	x				2-2 on page 2-1
	VNA Transmission Dynamic Range	x				2-3 on page 2-3
	VNA S-Parameters Measurements Accuracy	x				2-4 on page 2-5
	Power Monitor Measurement Accuracy		x			4-2 on page 4-1
	VNA Bias Tee Operational Check			x		4-3 on page 4-4
	GPS Operational Check				x	4-4 on page 4-6
MS2028C	VNA Frequency Accuracy	x				2-2 on page 2-1
	VNA Transmission Dynamic Range	x				2-3 on page 2-3
	VNA S-Parameters Measurements Accuracy	x				2-4 on page 2-5
	Power Monitor Measurement Accuracy		x			4-2 on page 4-1
	VNA Bias Tee Operational Check			x		4-3 on page 4-4
	GPS Operational Check				x	4-4 on page 4-6
MS2036C	VNA Frequency Accuracy	x				2-2 on page 2-1
	VNA Transmission Dynamic Range	x				2-3 on page 2-3
	VNA S-Parameters Measurements Accuracy	x				2-4 on page 2-5
	VNA Bias Tee Operational Check			x		4-3 on page 4-4
	GPS Operational Check				x	4-4 on page 4-6
	Spectrum Analyzer Residual Spurious Response	x				3-2 on page 3-1
	Spectrum Analyzer Displayed Average Noise Level (DANL)	x				3-3 on page 3-4
	Spectrum Analyzer Frequency Accuracy	x				3-4 on page 3-6
	Spectrum Analyzer Frequency Accuracy with GPS On				x	4-5 on page 4-8
	Spectrum Analyzer Single Side Band (SSB) Phase Noise	x				3-5 on page 3-8
	Spectrum Analyzer Spurious Response (Second Harmonic Distortion)	x				3-6 on page 3-11
	Spectrum Analyzer Input Related Spurious (IRS) Signals	x				3-7 on page 3-14
	Spectrum Analyzer Resolution Bandwidth Accuracy	x				3-8 on page 3-18
	Spectrum Analyzer Amplitude Accuracy	x				3-9 on page 3-21
Spectrum Analyzer Third Order Intercept (TOI)	x				3-10 on page 3-27	

Table 1-8. Required Performance Verification Procedures for each model of VNA Master (2 of 2)

Model	Performance Verification Procedure	Std	Opt 5	Opt 10	Opt 31	Procedure Sections
MS2038C	VNA Frequency Accuracy	x				2-2 on page 2-1
	VNA Transmission Dynamic Range	x				2-3 on page 2-3
	VNA S-Parameters Measurements Accuracy	x				2-4 on page 2-5
	VNA Bias Tee Operational Check			x		4-3 on page 4-4
	GPS Operational Check				x	4-4 on page 4-6
	Spectrum Analyzer Residual Spurious Response	x				3-2 on page 3-1
	Spectrum Analyzer Displayed Average Noise Level (DANL)	x				3-3 on page 3-4
	Spectrum Analyzer Frequency Accuracy	x				3-4 on page 3-6
	Spectrum Analyzer Frequency Accuracy with GPS On				x	4-5 on page 4-8
	Spectrum Analyzer Single Side Band (SSB) Phase Noise	x				3-5 on page 3-8
	Spectrum Analyzer Spurious Response (Second Harmonic Distortion)	x				3-6 on page 3-11
	Spectrum Analyzer Input Related Spurious (IRS) Signals	x				3-7 on page 3-14
	Spectrum Analyzer Resolution Bandwidth Accuracy	x				3-8 on page 3-18
	Spectrum Analyzer Amplitude Accuracy	x				3-9 on page 3-21
	Spectrum Analyzer Third Order Intercept (TOI)	x				3-10 on page 3-27

Chapter 2 — Vector Network Analyzer Performance Verification

2-1 Introduction

This chapter contains tests that can be used to verify the performance or operation of VNA Master models MS2026C, MS2028C, MS2036C, and MS2038C. The tests include:

- “Frequency Accuracy” on page 2-1
- “Transmission Dynamic Range” on page 2-3
- “S-Parameter Measurements Verification” on page 2-5

2-2 Frequency Accuracy

The following test can be used to verify the CW frequency accuracy of the vector network analyzer in MS2026C, MS2028C, MS2036C, and MS2038C. Measurement calibration of the VNA is not required for this test.

Equipment Required

- Frequency Counter, Anritsu Model MF2412B
- RF Coaxial Cable, Anritsu Model 3670NN50-2
- Adapter, Anritsu Model 34NFK50 (For units with Option 11)

Procedure

1. Press the **On/Off** key to turn on the VNA Master.
2. For an MS203xC VNA Master, press the **Shift** key and then the **Mode (9)** key. Use the rotary knob to highlight Vector Network Analyzer, and then press the **Enter** key to switch to Vector Network Analyzer mode.
3. Press the **Shift** key, the **Preset (1)** key, and then the **Preset** soft key to reset the instrument to the default starting conditions.

Note Before continuing, allow a 30-minute warm up for the internal circuitry to stabilize.

4. Press the **Measure** hard key and then the S-Parameter soft key. Press S21 and then press the **Enter** key to accept the selection.
5. Press the Number of Traces soft key and then press 1.
6. Press the Graph Type soft key. Then select Log Mag, and press **Enter** key to accept the selection.
7. Press the **Sweep** hard key and change the Data Points to 1000.
8. Press the **Freq/Time/Dist** hard key, and then press the Start Freq soft key.
9. Enter 2.6 and press the GHz soft key to set the Start Frequency to 2.6 GHz.
10. Press the Stop Freq soft key.
11. Enter 2.6 and press the GHz soft key to set the Stop Frequency to 2.6 GHz.
12. Attach the RF cable from the VNA Master Port 1 to the RF Input 1 connector on the Frequency Counter.
13. Turn on the Frequency Counter and press the **Preset** key.

14. Verify that the Frequency Counter reading is $2.6 \text{ GHz} \pm 3.9 \text{ kHz}$.
15. Record the result to the test record in [Appendix A](#):
 - MS2026C – [Table A-1, “VNA Frequency Accuracy” on page A-2.](#)
 - MS2028C – [Table A-3, “VNA Frequency Accuracy” on page A-3](#)
 - MS2036C – [Table A-5, “VNA Frequency Accuracy” on page A-4](#)
 - MS2038C – [Table A-26, “VNA Frequency Accuracy” on page A-14](#)

2-3 Transmission Dynamic Range

The following test is used to verify the transmission dynamic range of the vector network analyzer in the MS2026C, MS2028C, MS2036C, and MS2038C. The procedures are automated by selecting the Transmission Dynamic Range Test in the VNA Master Test software, part number 2300-535.

The VNA Master Verification software guides you to perform multiple, full 12-Term calibrations for different frequency bands on the VNA Master by using the appropriate calibration tees, to measure the transmission noise floor, and to calculate the Transmission Dynamic Range.

Equipment Required

- Calibration Tee, N male, Anritsu Model OSLN50
- Calibration Tee, N female, Anritsu Model OSLNF50
- RF Coaxial Cable, Anritsu Model 3670NN50-2
- Calibration Tee, K male, Anritsu Model OSLK50 (For units with Option 11)
- Calibration Tee, K female, Anritsu Model OSLKF50 (For units with Option 11)
- RF Coaxial Cable, Anritsu Model 3670K50-2 (For units with Option 11)
- Adapter, Anritsu Model 33KK50B (For units with Option 11)
- VNA Master Test Software, Anritsu part number 2300-535
- Personal Computer with Windows XP Operating System, Ethernet interface, and National Instruments VISA software version 4.4.1 or later

Procedure

1. Use a Cat5-E Ethernet cable to connect the VNA Master to a Local Area Network port that is close to the PC controller. Alternatively, use a Cat5-E Ethernet Crossover cable to connect the VNA Master directly to the PC Controller Ethernet port. Refer to the MS202xC and MS203xC User Guide, PN 10580-00305 for setup procedures.
2. Connect the RF cable to the VNA Master Port 2. Refer to [Figure 2-1](#) for the general hookup configuration. For MS2028C and MS2038C instruments with Option 11, install the 33KK50B Adapter to Port 2 and then to the RF cable.
3. Press the **On/Off** key to turn on the VNA Master.
4. Press the **Shift** key, the **Preset (1)** key, and then the **Preset** soft key to reset the instrument to the default starting conditions.

Note Before continuing, allow a 30-minute warm up for the internal circuitry to stabilize.

5. Turn on power to the PC and allow it complete the boot up process.
6. Run the VNA Master Test software.
7. Select Begin VNA Verification Button.
8. Follow the instructions of the software to connect the Open, Short, and Load of the calibration tees to Port 1 and to the open end of the RF cable (extended Port 2) for the measurement calibration. [Figure 2-1](#) shows the general calibration setup.

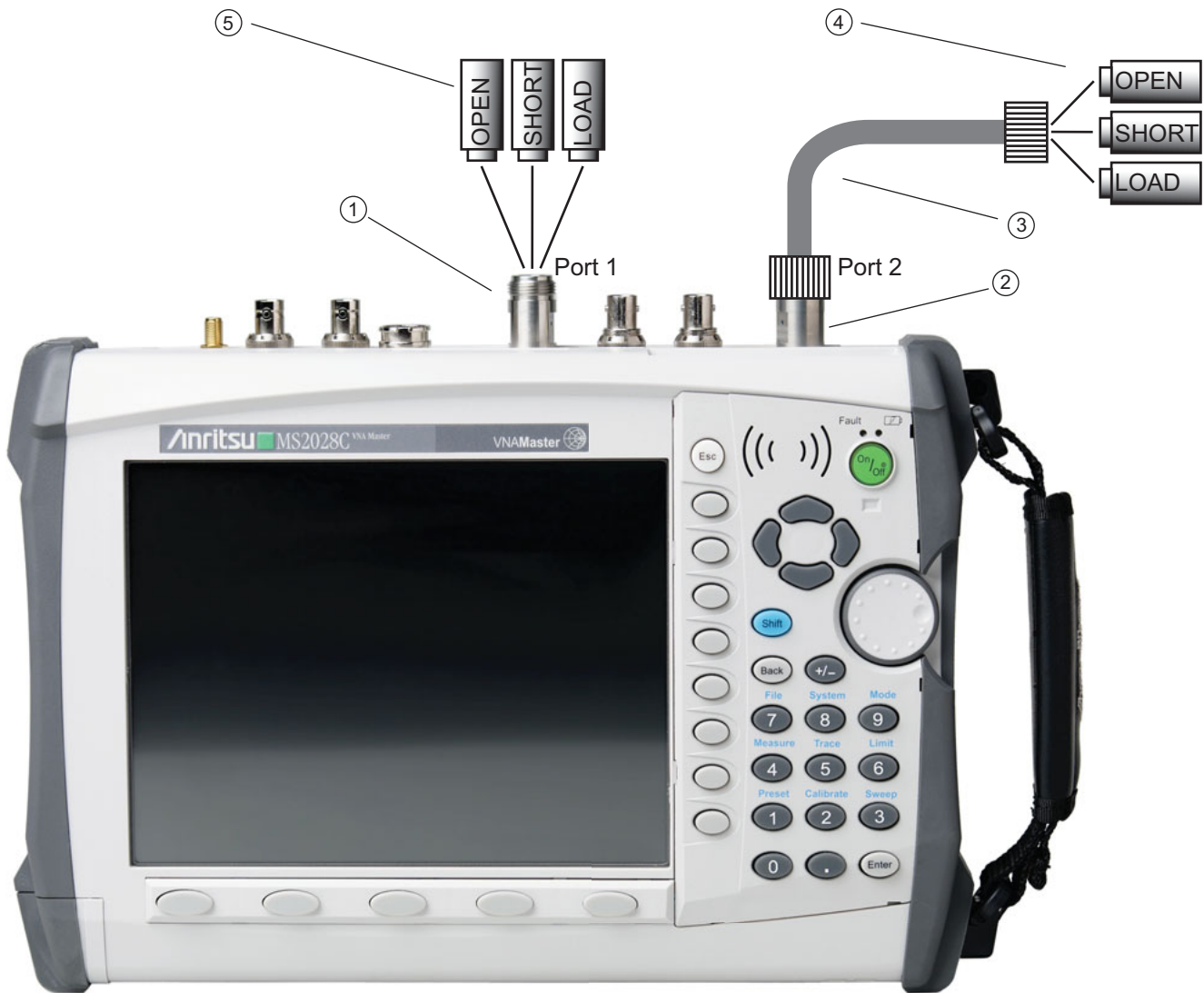

1. Test Port 1
2. Test Port 2
3. RF Test Cable
4. Open, Short, and Load of female OSL Calibration Tee
5. Open, Short, and Load of male OSL Calibration Tee

Figure 2-1. Calibration Setup

9. Follow the instructions of the software to perform measurements of the Transmission Noise Floor.
10. Pass/Fail status of the test is displayed on the computer. The software can also provide a hard copy (printout) of the test result, if desired.
11. Attach the printout of the test results to the test record in [Appendix A](#):
 - MS2026C – [Section “VNA Transmission Dynamic Range – MS2026C”](#) on page A-2.
 - MS2028C – [Section “VNA Transmission Dynamic Range – MS2028C”](#) on page A-3
 - MS2036C – [Section “VNA Transmission Dynamic Range – MS2036C”](#) on page A-4
 - MS2038C – [Section “VNA Transmission Dynamic Range – MS2038C”](#) on page A-14

2-4 S-Parameter Measurements Verification

The following test verifies S-parameter measurement capabilities of the VNA Master, calibration tees, test port cable, and any required adapters as a system by analyzing the measurement of artifacts that are traceable to national standards laboratories. The procedures are automated by selecting the S-parameter Measurement Verification Test in the VNA Master Verification software, which is supplied with each SC7858 or SC7859 Verification Kit.

The VNA Master Verification software guides you to perform a full 12 Term calibration on the VNA Master by using the appropriate calibration tees, to measure the S-parameters of the impedance transfer standards in the verification kit, and to verify that the measured values are within the specified measurement uncertainty limits.

The impedance transfer standards that are contained in the verification kit are:

- 20 dB Attenuation Standard
- 50 dB Attenuation Standard
- 50 ohm Air Line Standard
- 25 ohm Mismatch (Beatty) Standard

The devices in the verification kit are selected based on their ability to stress the envelope of possible measurement parameters while still providing a very stable and repeatable behavior. The key attribute of the devices is that of long term stability.

The quality of the verification result is dependent on the degree of care taken by the user in maintaining, calibrating, and using the system. The most critical factors are:

- The stability and quality of the devices in the calibration tee and the verification kit.
- The condition of the VNA test port connectors and test port cables.
- The pin depths of all connectors.
- The proper torquing of connections.

Caution The use of non-Anritsu calibration tees or verification kits is not supported.

Equipment Required

- Calibration Tee, N male, Anritsu Model OSLN50
- Calibration Tee, N female, Anritsu Model OSLNF50
- RF Coaxial Cable, Anritsu Model 3670NN50-2
- N Connector Verification Kit, Anritsu Model SC7858
- 3/4 inch and 12 lbf · in (1.35 N · m). Open End Torque Wrench, Anritsu 01-200
- Calibration Tee, K male, Anritsu Model OSLK50 (for units with Option 11)
- Calibration Tee, K female, Anritsu Model OSLKF50 (for units with Option 11)
- RF Coaxial Cable, Anritsu Model 3670K50-2 (for units with Option 11)
- Adapter, Anritsu Model 33KK50B (for units with Option 11)
- K Connector Verification Kit, Anritsu Model SC7859 (for units with Option 11)
- 5/16 inch and 8 lbf · in (0.9 N · m). Open End Torque Wrench, Anritsu 01-201 (for units with Option 11)
- Personal Computer with Microsoft Windows XP Operating System, USB port, Ethernet interface, and National Instruments VISA software version 4.4.1 or later

Special Precautions

When performing the procedures, observe the following precautions:

- Minimize vibration and movement of the system, attached components, and test cable.
- Clean and check the pin depth and condition of all adapters, test port cables, calibration components, and impedance transfer standards.
- Pre-shape the test cable so as to minimize its movement during calibration and measurement activities.

Procedure

1. Use a Cat5-E Ethernet cable to connect the VNA Master to a Local Area Network port that is close to the PC controller. Alternatively, use a Cat5-E Ethernet Crossover cable to connect the VNA Master directly to the PC Controller Ethernet port. Refer to the MS202xC and MS203xC User Guide, PN 10580-00305, for setup procedures.
2. Turn on power to the PC controller and the VNA Master.
3. Install the RF Coaxial Cable to Port 2 of the VNA Master. Install the 33KK50B Adapter to the open end of the cable if verifying the instrument with Option 11.
4. Run the VNA Master Verification software on the PC and select System Verification.
5. Verify that the PC controller is communicating with the VNA Master.
6. Insert the USB flash drive that is supplied with the verification kit to an available USB port on the PC controller. Set the data location of the verification software to the USB flash drive when prompted.
7. Follow the directions that are displayed on the computer to perform calibration with the appropriate calibration kit.

Caution	Use an appropriate torque wrench to insure proper connection of calibration devices during calibration.
----------------	---

8. Follow the directions on the computer to perform measurements of impedance transfer standards of the appropriate verification kit.

Caution	Use an appropriate torque wrench to insure proper connection of verification standard devices prior to starting verification measurements.
----------------	--

9. Pass/Fail status of the measurements is displayed on the computer. The software can also provide a hard copy (printout) of the measured data, the measurement uncertainties, and the impedance transfer standards that have been used.
10. Attach the printout of the test results to the test record in [Appendix A](#):
 - MS2026C – [Section “VNA S-Parameter Measurements Verification – MS2026C”](#) on page A-2.
 - MS2028C – [Section “VNA S-Parameter Measurements Verification – MS2028C”](#) on page A-3
 - MS2036C – [Section “VNA S-Parameter Measurements Verification – MS2036C”](#) on page A-4
 - MS2038C – [Section “VNA S-Parameter Measurements Verification – MS2038C”](#) on page A-14

If Verification Fails

If the verification fails, then check the quality, cleanliness, and installation methods for the calibration and verification components. Specifically, check:

- The VNA test port connectors
- The calibration tee
- The impedance transfer standards
- The test port cables, for damage and cleanliness
- The test port cables, for proper connection and torquing
- The test port cables, for phase stability

These are the most common causes for verification failures.

Chapter 3 — Spectrum Analyzer Performance Verification

3-1 Introduction

This chapter contains tests that can be used to verify the performance or operation of the spectrum analyzer in VNA Master models MS2036C and MS2038C. The tests include:

- “Residual Spurious Response”
- “Displayed Average Noise level (DANL)”
- “Frequency Accuracy”
- “Single Side Band (SSB) Phase Noise”
- “Spurious Response (Second Harmonic Distortion)”
- “Input Related Spurious (IRS) Signals”
- “Resolution Bandwidth Accuracy”
- “Amplitude Accuracy”
- “Third Order Intercept (TOI)”

3-2 Residual Spurious Response

The following test is used to verify the residual spurious response of the spectrum analyzer in VNA Master models MS2036C and MS2038C and is performed by using the positive peak detection mode.

Equipment Required

- 50 ohm Termination, Anritsu Model 28N50-2
- 50 ohm Termination, Anritsu Model 28K50 (For MS2038C with Option 11 Only)

Procedure

1. Connect the 50 ohm Termination to the Spectrum Analyzer RF In connector of the MS203xC.
2. Press the **On/Off** key to turn on the MS203xC.
3. Press the **Shift** key and then the **Mode (9)** key. Use the rotary knob to highlight Spectrum Analyzer, and then press the **Enter** key to switch to Spectrum Analyzer mode.
4. Press the **Shift** key, the **Preset (1)** key, and then the Preset soft key to reset the instrument to the default starting conditions
5. Press the **Shift** key, the **Sweep (3)** key. Press the Sweep Mode soft key, and then press the Performance soft key to set the instrument to Performance Sweep mode.

Note Before continuing, allow a 30-minute warm up for the internal circuitry to stabilize.

Residual Spurious Response with Preamp Off

6. Press the **Amplitude** hard key and then the Reference Level soft key.
7. Enter -40 and press the dBm soft key to set Reference Level to -40 dBm.
8. Press the Atten Lvl soft key.
9. Enter 0 and press the dB soft key to set Atten Lvl to 0 dB.

10. Ensure that the Pre Amp soft key is in the Off position. If the preamp is On, then press the Pre Amp soft key to turn it Off.
11. Press the Detection soft key and ensure that Peak is selected.
12. Press the **Freq** hard key and then the Start Freq soft key.
13. Enter 9 and then press the kHz soft key to set Start Frequency to 9 kHz.
14. Press the Stop Freq soft key.
15. Enter 100 and then press the kHz soft key to set Stop Frequency to 100 kHz.
16. Press the **BW** hard key and then the RBW soft key.
17. Enter 300 and then press the Hz soft key to set RBW to 300 Hz.
18. Press the VBW soft key.
19. Enter 10 and then press the Hz soft key to set VBW to 10 Hz.
20. Wait until one sweep is completed.
21. Press the **Marker** hard key and then the Peak Search soft key.
22. Record the Marker 1 amplitude reading in [Table A-6, "Spectrum Analyzer Residual Spurious Response with Preamp Off" on page A-5](#) for MS2036C, or in [Table A-27, "Spectrum Analyzer Residual Spurious Response with Preamp Off" on page A-15](#) for MS2038C in [Appendix A](#) and verify that the amplitude is within specification.

Note

If a spurious signal with amplitude exceeding specification occurs, then wait another full sweep and observe whether the spurious signal occurs at the same point on the second sweep. If the spurious signal does not occur at the same point on the second sweep, then the spurious signal on the first sweep was not real.

23. Repeat [Step 12](#) through [Step 22](#) for the other Start and Stop frequencies with the RBW and VBW settings as listed in [Table A-6](#) for MS2036C or in [Table A-27](#) for MS2038C.

Residual Spurious Response with Preamp On

24. Press the **Amplitude** hard key and then the Reference Level soft key.
25. Enter -50 and press the dBm soft key to set Reference Level to -50 dBm.
26. Ensure that Atten Lvl is set to 0 dB.
27. Press the Pre Amp soft key to turn Pre Amp to On.
28. Press the **Freq** hard key and then the Start Freq soft key.
29. Enter 1 and then press the MHz soft key to set Start Frequency to 1 MHz.
30. Press the Stop Freq soft key.
31. Enter 10 and then press the MHz soft key to set Stop Frequency to 10 MHz.
32. Press the **BW** hard key and then the RBW soft key.
33. Enter 3 and then press the kHz soft key to set RBW to 3 kHz.
34. Press the VBW soft key.
35. Enter 300 and then press the Hz soft key to set VBW to 300 Hz.
36. Wait until one sweep is completed.
37. Press the **Marker** hard key and then the Peak Search soft key.
38. Record the Marker 1 amplitude reading in [Table A-7, "Spectrum Analyzer Residual Spurious Response with Preamp On" on page A-5](#) for the MS2036C, or in [Table A-28, "Spectrum Analyzer Residual Spurious Response with Preamp On" on page A-15](#) for the MS2038C in [Appendix A](#) and verify that the amplitude is within specification.

Response with Preamp On” on page A-16 for the MS2038C in Appendix A and verify that it is within specification.

Note

If a spurious signal with amplitude exceeding specification occurs, then wait another full sweep and observe whether the spurious signal occurs at the same point on the second sweep. If the spurious signal does not occur at the same point on the second sweep, then the spurious signal on the first sweep was not real.

39. Repeat Step 28 through Step 38 for the other Start and Stop frequencies with the RBW and VBW settings as listed in Table A-7 for MS2036C or in Table A-28 for MS2038C.

3-3 Displayed Average Noise level (DANL)

The following test is used to verify the displayed average noise level (DANL) of the spectrum analyzer in VNA Master models MS2036C and MS2038C and is performed using the RMS/Avg detection mode.

Equipment Required

- 50 ohm Termination, Anritsu Model 28N50-2
- 50 ohm Termination, Anritsu Model 28K50 (For MS2038C with Option 11 Only)

Procedure

1. Connect the 50 ohm Termination to the Spectrum Analyzer RF In connector of the MS203xC.
2. Press the **On/Off** key to turn on the MS203xC.
3. Press the **Shift** key and then the **Mode (9)** key. Use the rotary knob to highlight Spectrum Analyzer and then press the **Enter** key to switch to Spectrum Analyzer mode.
4. Press the **Shift** key, the **Preset (1)** key, and then the **Preset** soft key to reset the instrument to the default starting conditions.
5. Press the **Shift** key, the **Sweep (3)** key, press the **Sweep Mode** soft key. Then press the **Performance** soft key to set the instrument to Performance Sweep mode.

Note Before continuing, allow a 30-minute warm up for the internal circuitry to stabilize.

Displayed Average Noise Level with Preamp Off

6. Press the **Amplitude** hard key and then the **Reference Level** soft key.
7. Enter -20 and press the **dBm** soft key to set Reference Level to -20 dBm.
8. Press the **Atten Lvl** soft key.
9. Enter 0 and press the **dB** soft key to set Atten Lvl to 0 dB.
10. Ensure that the **Pre Amp On/Off** soft key is in the **Off** position. If the preamp is **On**, then press the **Pre Amp On/Off** soft key to turn it **Off**.
11. Press the **Detection** soft key and then the **RMS/Avg** soft key.
12. Press the **BW** hard key and then the **RBW** soft key.
13. Enter 100 and then press the **kHz** soft key to set RBW to 100 kHz.
14. Press the **VBW** soft key.
15. Enter 1 and then press the **kHz** soft key to set VBW to 1 kHz.
16. Press the **VBW/Average Type** soft key and ensure that **Log** is selected.
17. Press the **Freq** hard key and then the **Start Freq** soft key.
18. Enter 10 and then press the **MHz** soft key to set Start Frequency to 10 MHz.
19. Press the **Stop Freq** soft key.
20. Enter 4 and then press the **GHz** soft key to set Stop Frequency to 4 GHz.
21. Wait until one sweep is completed.
22. Press the **Marker** hard key and then the **Peak Search** soft key.
23. Record the Marker 1 amplitude reading into the Measured Value (100 kHz RBW) column of [Table A-8, "Spectrum Analyzer DANL with Preamp Off" on page A-6](#) for MS2036C or in [Table A-29, "Spectrum Analyzer DANL with Preamp Off" on page A-16](#) for MS2038C in [Appendix A](#).
24. Repeat [Step 17](#) through [Step 23](#) for the other Start and Stop frequencies that are listed in [Table A-8](#) for MS2036C or in [Table A-29](#) for MS2038C.

25. For each measured 100 kHz RBW value in [Table A-8](#) for MS2036C or in [Table A-29](#) for MS2038C in [Appendix A](#), normalize the value to 1 Hz RBW by subtracting 50 dB. For example, if the marker shows a value of -100 dBm at 100 kHz RBW, then the calculated value at 1 Hz RBW is -150 dBm.

Example equation:

$$-100 \text{ dBm} - (50 \text{ dB}) = -150 \text{ dBm}$$

26. Record the calculated values in the Calculated Value (1 Hz RBW) column in [Table A-8](#) for MS2036C or in [Table A-29](#) for MS2038C in [Appendix A](#). Verify that the calculated value is within specification.

Displayed Average Noise Level with Preamp On

27. Press the **Amplitude** hard key and then the Reference Level soft key.
28. Enter -50 and press the dBm soft key to set Reference Level to -50 dBm.
29. Ensure that Atten Lvl is set to 0 dB.
30. Press the Pre Amp On/Off soft key to turn Pre Amp On.
31. Press the **Freq** hard key and then the Start Freq soft key.
32. Enter 10 and then press the MHz soft key to set Start Frequency to 10 MHz.
33. Press the Stop Freq soft key.
34. Enter 4 and then press the GHz soft key to set Stop Frequency to 4 GHz.
35. Wait until one sweep is completed.
36. Press the **Marker** hard key and then the Peak Search soft key.
37. Record the Marker 1 amplitude reading into the Measured Value (100 kHz RBW) column of [Table A-9](#), “Spectrum Analyzer DANL with Preamp On” on page A-6 for MS2036C or in [Table A-30](#), “Spectrum Analyzer DANL with Preamp On” on page A-16 for MS2038C in [Appendix A](#).
38. Repeat [Step 31](#) through [Step 37](#) for the other Start and Stop frequencies listed in [Table A-9](#) for MS2036C or in [Table A-30](#) for MS2038C.
39. For each measured 100 kHz RBW value in [Table A-9](#) for MS2036C or in [Table A-30](#) for MS2038C in [Appendix A](#), normalize the value to 1 Hz RBW by subtracting 50 dB. For example, if the marker shows a value of -110 dBm at 100 kHz RBW, then the calculated value at 1 Hz RBW is -160 dBm.

Example equation:

$$-110 \text{ dBm} - (50 \text{ dB}) = -160 \text{ dBm}$$

40. Record the calculated values into the Calculated Value (1 Hz RBW) column in [Table A-9](#) for MS2036C or in [Table A-30](#) for MS2038C in [Appendix A](#). Verify that the calculated value is within specification.

3-4 Frequency Accuracy

The following test can be used to verify the frequency accuracy of the spectrum analyzer in VNA Master models MS2036C and MS2038C.

Equipment Required

- 10 MHz Frequency Reference Standard, Symmetricom Model Rubisource T&M
- Synthesized Signal Generator, Anritsu Model MG3692X
- K(m) to N(f) Adapter, Anritsu Model 34RKNF50
- N(m) to N(m) RF Coaxial Cable, Anritsu Model 15NN50-1.0B
- BNC(m) to BNC(m) RF Coaxial Cable, Anritsu part number 2000-1627-R
- N(f) to K(m) Adapter, Anritsu 34NFK50 (for MS2038C with Option 11 Only)

Procedure

1. Connect the 10 MHz Reference to the Anritsu MG3692X Synthesized Signal Generator.

Caution Do not connect the 10 MHz Reference to the VNA Master.

2. Turn on the 10 MHz Reference Standard and the Anritsu MG3692X Synthesized Signal Generator.
3. Press the **On/Off** key to turn on the MS203xC VNA Master.
4. On the MS203xC VNA Master, press the **Shift** key and then the **Mode (9)** key. Use the rotary knob to highlight Spectrum Analyzer, and then press the **Enter** key to switch to Spectrum Analyzer mode.
5. Press the **Shift** key, the **Preset (1)** key, and then the **Preset** soft key to reset the instrument to the default starting conditions.
6. Press the **Shift** key, the **Sweep (3)** key, and the **Sweep Mode** soft key, and then press the **Performance** soft key to set the instrument to Performance Sweep mode.

Note Before continuing, allow a 30-minute warm up for the internal circuitry to stabilize.

7. Set the MG3692X output to 1 GHz CW, with an RF Output Level of -30 dBm.
8. Connect the output of the Synthesized Signal Generator to the Spectrum Analyzer RF Input of the VNA Master.
9. On the MS203xC VNA Master, press the **Amplitude** hard key and then the **Reference Level** soft key.
10. Enter -10 and then press the **dBm** soft key to set Reference Level to -10 dBm.
11. Press the **Span** hard key.
12. Enter 10 and then press the **kHz** soft key to set Span to 10 kHz.
13. Press the **BW** hard key and then the **RBW** soft key.
14. Enter 100 and then press the **Hz** soft key to set RBW to 100 Hz.
15. Press the **VBW** soft key.
16. Enter 30 and then press the **Hz** soft key to set VBW to 30 Hz.
17. Press the **Freq** hard key and then the **Center Freq** soft key.
18. Enter 1 and then press the **GHz** soft key to set Center Frequency to 1 GHz.
19. Press the **Marker** hard key and then the **More** soft key.
20. Press the **Counter Marker** soft key to turn it On.
21. Press the **Back** soft key and then the **Peak Search** soft key.

22. Record the marker frequency value into [Table A-10](#), “Spectrum Analyzer Frequency Accuracy” on page A-6 for MS2036C or into [Table A-31](#), “Spectrum Analyzer Frequency Accuracy” on page A-17 for MS2038C in [Appendix A](#).
23. Verify that the value is $1 \text{ GHz} \pm 300 \text{ Hz}$ ($\pm 0.3 \text{ ppm}$).
24. Set the MS3692X output to 7 GHz CW.
25. On the MS203xC VNA Master, press the **Freq** hard key and then the Center Freq soft key.
26. Enter 7 and then press the GHz soft key to set Center Frequency to 7 GHz.
27. Press the **Marker** hard key and then Peak Search soft key.
28. Record the marker frequency value into [Table A-10](#) for MS2036C or into [Table A-31](#) for MS2038C in [Appendix A](#).
29. Verify that the value is $7 \text{ GHz} \pm 2.1 \text{ kHz}$ ($\pm 0.3 \text{ ppm}$).

3-5 Single Side Band (SSB) Phase Noise

This test is used to verify the single side band (SSB) phase noise of the spectrum analyzer in VNA Master models MS2036C and MS2038C.

Equipment Required

- 10 MHz Frequency Reference Standard, Symmetricom Model Rubisource T&M
- Synthesized Signal Generator, Anritsu Model MG3692X
- K(m) to N(f) Adapter, Anritsu Model 34RKNF50
- N(m) to N(m) RF Coaxial Cable, Anritsu Model 15NN50-1.0B
- BNC(m) to BNC(m) RF Coaxial Cable, Anritsu part number 2000-1627-R
- N(f) to K(m) Adapter, Anritsu Model 34NFK50 (for MS2038C with Option 11 Only)

Procedure

1. Connect the 10 MHz Reference to the Anritsu MG3692X Synthesized Signal Generator.
2. Turn on the 10 MHz Reference Standard and the Anritsu MG3692X Synthesized Signal Generator.
3. Press the **On/Off** key to turn on the MS203xC VNA Master.
4. Press the **Shift** key and then the **Mode (9)** key. Use the rotary knob to highlight Spectrum Analyzer, and then press the **Enter** key to switch to Spectrum Analyzer mode.
5. Press the **Shift** key, the **Preset (1)** key, and then the **Preset** soft key to reset the instrument to the default starting conditions.
6. Press the **Shift** key, the **Sweep (3)** key, press the **Sweep Mode** soft key and then press the **Performance** soft key to set the instrument to Performance Sweep mode.

Note Before continuing, allow a 30-minute warm up for the internal circuitry to stabilize.

7. Set the MG3692X output to 1 GHz CW, with an RF Output Level of 4 dBm.
8. Connect the output of the Synthesized Signal Generator to the Spectrum Analyzer RF Input of the VNA Master.
9. On the MS203xC VNA Master, press the **Amplitude** hard key and then the **Reference Level** soft key.
10. Enter 5 and then press the **dBm** soft key to set Reference Level to 5 dBm.
11. Press the **Atten Lvl** soft key.
12. Enter 15 and then press the **dB** soft key to set Atten Lvl to 15 dB.
13. Press the **Freq** hard key and then the **Center Freq** soft key.
14. Enter 1 and then press the **GHZ** soft key to set Center Freq to 1 GHz.
15. Press the **Span** hard key/
16. Enter 110 and then press the **kHz** soft key to set Span to 110 kHz.
17. Press the **BW** hard key and then the **RBW** soft key.
18. Enter 1 and then press the **kHz** soft key to set RBW to 1 kHz.
19. Press the **VBW** soft key.
20. Enter 3 and then press the **Hz** soft key to set VBW to 3 Hz.
21. Press the **Shift** key, the **Trace (5)** key and then the **Trace A Operations** soft key.
22. Press the **# of Averages** soft key.
23. Enter 3 and then press the **Enter** key.

24. Wait until the Trace Count displays 3/3.
25. Press the **Marker** hard key and then the **Peak Search** soft key.
26. Press the **Delta On/Off** soft key to turn On the Delta Marker.
27. Enter 10 and press the **kHz** soft key to set Delta frequency to 10 kHz.
28. Record the Marker readout value into the Measured Value column of [Table A-12, “Spectrum Analyzer SSB Phase Noise” on page A-7](#) for MS2036C or of [Table A-33, “Spectrum Analyzer SSB Phase Noise” on page A-17](#) for MS2038C in [Appendix A](#).
29. Subtract 30 dB from the Measured Value and record the result to the Calculated Value column of [Table A-12](#) for MS2036C or of [Table A-33](#) for MS2038C in [Appendix A](#).

Example equation:

$$-70 \text{ dBc measured } -30 \text{ dB} = -100 \text{ dBc/Hz}$$

30. Verify that the calculated result is less than the specification for 10 kHz Offset.
31. Press the **Marker** hard key and then the **Delta On/Off** soft key to turn Off Delta Marker.
32. Press the **Span** hard key.
33. Enter 220 and then press the **kHz** soft key to set Span to 220 kHz.
34. Wait until the Trace Count displays 3/3.

Note After setting the new span, Trace Count continues to display 3/3 until a sweep is complete. Then it starts to count from 1/3.

35. Press the **Marker** hard key and then the **Peak Search** soft key.
36. Press the **Delta On/Off** soft key to turn On Delta Marker.
37. Enter 100 and press the **kHz** soft key to set Delta frequency to 100 kHz.
38. Record the Marker readout value into the Measured Value column of [Table A-12, “Spectrum Analyzer SSB Phase Noise” on page A-7](#) for MS2036C or of [Table A-33, “Spectrum Analyzer SSB Phase Noise” on page A-17](#) for MS2038C in [Appendix A](#).
39. Subtract 30 dB from the Measured Value and record the result to the Calculated Value column of [Table A-12](#) for MS2036C or of [Table A-33](#) for MS2038C in [Appendix A](#).
40. Verify that the calculated result is less than the specification for 100 kHz Offset.
41. Press the **Delta On/Off** soft key to turn Off the Delta Marker.
42. Press the **Span** hard key.
43. Enter 2.2 and then press the **MHz** soft key to set Span to 2.2 MHz.
44. Wait until the Trace Count displays 3/3.
45. Press the **Marker** hard key and then the **Peak Search** soft key.
46. Press the **Delta On/Off** soft key to turn On Delta Marker.
47. Enter 1 and press the **MHz** soft key to set Delta frequency to 1 MHz.
48. Record the Marker readout value into the Measured Value column of [Table A-12](#) for MS2036C or of [Table A-33](#) for MS2038C in [Appendix A](#).
49. Subtract 30 dB from the Measured Value and record the result to the Calculated Value column of [Table A-12](#) for MS2036C or of [Table A-33](#) for MS2038C in [Appendix A](#).
50. Verify that the calculated result is less than the specification for 1 MHz Offset.
51. Press the **Delta On/Off** soft key to turn Off Delta Marker.
52. Press the **Span** hard key.

53. Enter 22 and then press the MHz soft key to set Span to 22 MHz.
54. Wait until the Trace Count displays 3/3.
55. Press the **Marker** hard key and then the **Peak Search** soft key.
56. Press the Delta On/Off soft key to turn On Delta Marker.
57. Enter 10 and press the MHz soft key to set Delta frequency to 10 MHz.
58. Record the Marker readout value into the Measured Value column of [Table A-12](#) for MS2036C or of [Table A-33](#) for MS2038C in [Appendix A](#).
59. Subtract 30 dB from the Measured Value and record the result to the Calculated Value column of [Table A-12](#) for MS2036C or of [Table A-33](#) for MS2038C in [Appendix A](#).
60. Verify that the calculated result is less than the specification for 10 MHz Offset.

3-6 Spurious Response (Second Harmonic Distortion)

The following test is used to verify the input related spurious response of the spectrum analyzer in VNA Master models MS2036C and MS2038C.

Equipment Required

- 10 MHz Frequency Reference Standard, Symmetricom Model Rubisource T&M
- Synthesized Signal Generator, Anritsu Model MG3692X
- K(m) to N(f) Adapter, Anritsu Model 34RKNF50
- N(m) to N(m) RF Coaxial Cable, Anritsu Model 15NN50-1.0B
- BNC(m) to BNC(m) RF Coaxial Cable, Anritsu part number 2000-1627-R
- 50 MHz Low Pass Filter, Anritsu Part Number 1030-96
- N(f) to K(m) Adapter, Anritsu 34NFK50 (for MS2038C with Option 11 Only)

Procedure

1. Connect the 10 MHz Reference to the Anritsu MG3692X Synthesized Signal Generator.
2. Turn on the 10 MHz Reference Standard and the Anritsu MG3692X Synthesized Signal Generator.
3. Press the **On/Off** key to turn on the MS203xC VNA Master.
4. Press the **Shift** key and then the **Mode (9)** key. Use the rotary knob to highlight Spectrum Analyzer, and then press the **Enter** key to switch to Spectrum Analyzer mode.
5. Press the **Shift** key, the **Preset (1)** key, and then the **Preset** soft key to reset the instrument to the default starting conditions.
6. Press the **Shift** key, the **Sweep (3)** key, press the **Sweep Mode** soft key and then press the **Performance** soft key to set the instrument to Performance Sweep mode.

Note Before continuing, allow a 30-minute warm up for the internal circuitry to stabilize.

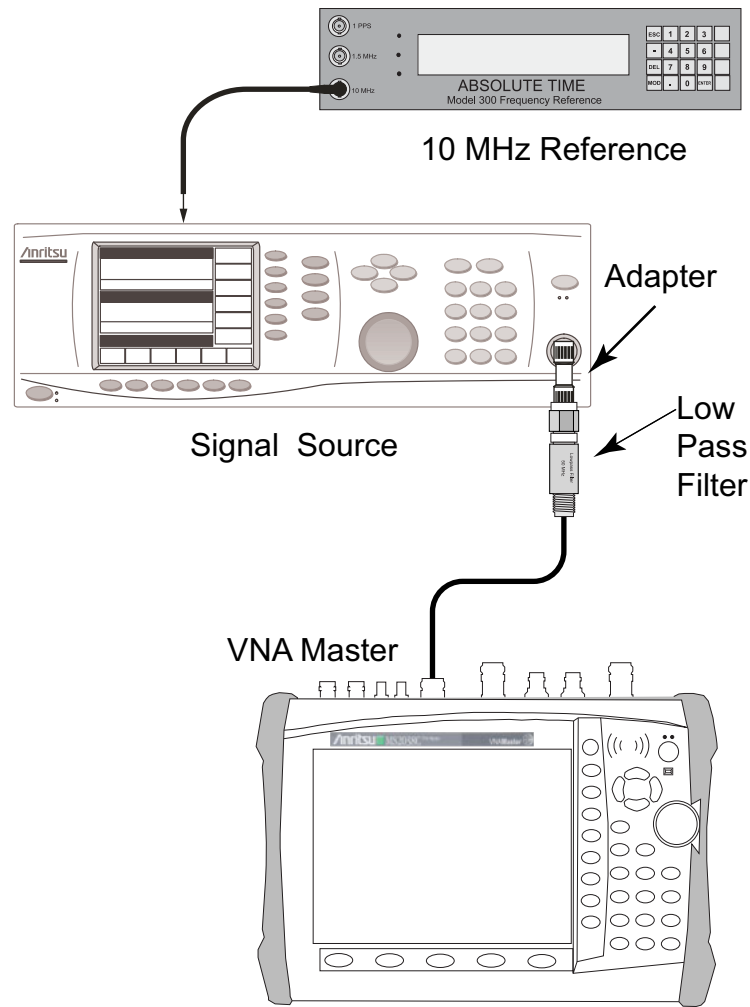

Figure 3-1. Second Harmonic Distortion - Spurious Response

7. Connect the output of the Synthesized Signal Generator to the 50 MHz Low Pass Filter.
8. Connect the Low Pass Filter to the Spectrum Analyzer RF Input of the VNA Master.
9. Set the MG3692X output to 50.1 MHz CW, with an RF Output Level of -30 dBm.
10. Press the **Amplitude** hard key and then the Reference Level soft key.
11. Enter -27 and then press the dBm soft key to set Reference Level to -27 dBm.
12. Press the Atten Lvl soft key.
13. Enter 0 and then press the dB soft key to set Atten Lvl to 0 dB.
14. Press the Detection soft key and then the Peak soft key to set the instrument to Peak Detection Mode.
15. Press the **Span** hard key.
16. Enter 100 and then press the kHz soft key to set Span to 100 kHz.
17. Press the **BW** hard key and then the RBW soft key.
18. Enter 1 and then press the kHz soft key to set RBW to 1 kHz.
19. Press the VBW soft key.
20. Enter 10 and then press the Hz soft key to set VBW to 10 Hz.

21. Press the **Freq** hard key and then the Center Freq soft key.
22. Enter 50.1 and then press the MHz soft key to set Center Freq to 50.1 MHz.
23. Press the **Shift** key and then press the **Trace (5)** key.
24. Press the Trace A Operations soft key and then the # of Averages soft key.
25. Enter 5 and then press the **Enter** key to set # of Averages to 5.
26. Wait until the Trace Count displays 5/5.
27. Press the **Marker** hard key and then the Peak Search soft key.
28. Record the amplitude at 50.1 MHz in [Table A-13, "Spectrum Analyzer Spurious Response \(Second Harmonic Distortion\)" on page A-7](#) for MS2036C or in [Table A-34, "Spectrum Analyzer Spurious Response \(Second Harmonic Distortion\)" on page A-17](#) for MS2038C.
29. Press the **Freq** hard key and then the Center Freq soft key.
30. Enter 100.2 and then press the MHz soft key to set Center Freq to 100.2 MHz.
31. Wait until the Trace Count displays 5/5.
32. Press the **Marker** hard key.
33. Enter 100.2 and then press the MHz soft key to set the Marker Frequency to 100.2 MHz.
34. Record the amplitude at 100.2 MHz in [Table A-13](#) for MS2036C or in [Table A-34](#) for MS2038C.
35. Calculate the 2nd Harmonic level in dBc by subtracting the 50.1 MHz amplitude from the 100.2 MHz amplitude by using the following formula:
$$\text{2nd Harmonic level dBc} = \text{100.2 MHz amplitude} - \text{50.1 MHz amplitude}$$
36. Record the calculated 2nd Harmonic level value in [Table A-13](#) for MS2036C or in [Table A-34](#) for MS2038C and verify that the calculated value is ≤ -54 dBc.

3-7 Input Related Spurious (IRS) Signals

The following test is used to verify the input related spurious signals of the spectrum analyzer in VNA Master models MS2036C and MS2038C.

Equipment Required

- 10 MHz Frequency Reference Standard, Symmetricom Model Rubisource T&M
- Synthesized Signal Generator, Anritsu Model MG3692X
- K(m) to N(f) Adapter, Anritsu Model 34RKNF50
- N(m) to N(m) RF Coaxial Cable, Anritsu Model 15NN50-1.0B
- BNC(m) to BNC(m) RF Coaxial Cable, Anritsu part number 2000-1627-R
- N(f) to K(m) Adapter, Anritsu 34NFK50 (For MS2038C with Option 11 Only)

Procedure

1. Connect the 10 MHz Reference to the Anritsu MG3692X Synthesized Signal Generator.
2. Turn on the 10 MHz Reference Standard and the Anritsu MG3692X Synthesized Signal Generator.
3. Press the **On/Off** key to turn on the MS203xC VNA Master.
4. Press the **Shift** key and then the **Mode (9)** key. Use the rotary knob to highlight Spectrum Analyzer, and then press the **Enter** key to switch to Spectrum Analyzer mode.
5. Press the **Shift** key, the **Preset (1)** key, and then the Preset soft key to reset the VNA Master to the default starting conditions.
6. Press the **Shift** key, the **Sweep (3)** key, press the Sweep Mode soft key, and then press the Performance soft key to set the VNA Master to Performance Sweep mode.

Note Before continuing, allow a 30-minute warm up for the internal circuitry to stabilize.

7. Connect the output of the Synthesized Signal Generator to the Spectrum Analyzer RF In connector of the VNA Master.

1000 MHz Input Related Spurious Check

8. Set the MG3692X output to 1000 MHz CW, with an RF output level of -30 dBm.
9. On the MS203xC VNA Master, press the **Amplitude** hard key and then the Reference Level soft key.
10. Enter -27 and then press the dBm soft key to set Reference Level to -27 dBm.
11. Press the Atten Lvl soft key.
12. Enter 0 and then press the dB soft key to set Atten Lvl to 0 dB.
13. Press the Detection soft key and then the Peak soft key to set the instrument to Peak Detection Mode.
14. Press the **Freq** hard key and then the Center Freq soft key.
15. Enter 1000 and then press the MHz soft key to set Center Freq to 1000 MHz.
16. Press the **Span** hard key.
17. Enter 2 and then press the MHz soft key to set Span to 2 MHz.
18. Press the **BW** hard key and then the RBW soft key.
19. Enter 1 and then press the kHz soft key to set RBW to 1 kHz.
20. Press the VBW soft key.
21. Enter 100 and then press the Hz soft key to set VBW to 100 Hz.

22. Wait until one sweep is completed.
23. Press the **Marker** hard key and then the **Peak Search** soft key.
24. Record the Marker amplitude reading for 1000 MHz into [Table A-14, “Spectrum Analyzer Input Related Spurious \(IRS\) Signals”](#) on page A-7 for MS2036C and into [Table A-35, “Spectrum Analyzer Input Related Spurious \(IRS\) Signals”](#) on page A-18 for MS2038C.
25. Press the **Freq** hard key and then press the **Start Freq** soft key.
26. Enter 719 and press the **MHz** soft key to set Start Freq to 719 MHz.
27. Press the **Stop Freq** soft key.
28. Enter 721 and press the **MHz** soft key to set Stop Freq to 721 MHz.
29. Wait until one sweep is completed.
30. Press the **Marker** hard key and then the **Peak Search** soft key.
31. Record the Marker M1 amplitude reading into the Measured Value column for 719 MHz to 721 MHz in [Table A-14](#) for MS2036C and [Table A-35](#) for MS2038C.
32. Calculate the input related spurious level using the following formula:

$$\text{Input Related Spurious dBc} = \text{Marker M1 Amplitude Reading} - \text{Amplitude Reading of 1000 MHz}$$
33. Record the calculated value into the Calculated IRS column for 719 MHz to 721 MHz in [Table A-14](#) for MS2036C and [Table A-35](#) for MS2038C and verify that it is ≤ -60 dBc.

3273 MHz Input Related Spurious Check

34. Set the MG3692X output to 3273 MHz CW, with an RF output level of -30 dBm.
35. On the MS203xC VNA Master, press the **Freq** hard key and then the **Center Freq** soft key.
36. Enter 3273 and then press the **MHz** soft key to set Center Freq to 3273 MHz.
37. Press the **BW** hard key and then the **RBW** soft key.
38. Enter 10 and then press the **kHz** soft key to set RBW to 10 kHz.
39. Press the **VBW** soft key.
40. Enter 1 and then press the **kHz** soft key to set VBW to 1 kHz.
41. Press the **Shift** key and then press the **Trace (5)** key.
42. Press the **Trace A Operations** soft key and then the **# of Averages** soft key.
43. Enter 5 and then press the **Enter** key to set # of Averages to 5.
44. Wait until the Trace Count displays 5/5.
45. Press the **Marker** hard key and then the **Peak Search** soft key.
46. Record the Marker amplitude reading of 3273 MHz into [Table A-14](#) for MS2036C or into [Table A-35](#) for MS2038C.
47. Press the **Freq** hard key and then the **Start Freq** soft key.
48. Enter 2423 and then press the **MHz** soft key to set Start Freq to 2423 MHz.
49. Press the **Stop Freq** soft key.
50. Enter 3271 and press the **MHz** soft key to set Stop Freq to 3271 MHz.
51. Wait until Trace Count displays 5/5.

Note

After the new frequency range has been set, Trace Count continues to display 5/5 until a new sweep is complete. Then it starts to count from 1/5.

52. Press the **Marker** hard key and then the **Peak Search** soft key.
53. Record the Marker M1 amplitude reading into the Measured Value column for 2423 MHz to 3271 MHz in [Table A-14 on page A-7](#) for MS2036C and in [Table A-35 on page A-18](#) for MS2038C.
54. Calculated the input related spurious level using the following formula:

$$\text{Input Related Spurious dBc} = \text{Marker M1 Amplitude Reading} - \text{Amplitude Reading of 3273 MHz}$$

55. Record the calculated value into the Calculated IRS column for 2423 MHz to 3271 MHz in [Table A-14](#) for MS2036C and in [Table A-35](#) for MS2038C and verify that it is ≤ -60 dBc.
56. Press the **Freq** hard key and then the **Start Freq** soft key.
57. Enter 3275 and then press the MHz soft key to set Start Freq to 3275 MHz.
58. Press the **Stop Freq** soft key.
59. Enter 4123 and press the MHz soft key to set Stop Freq to 4123 MHz.
60. Wait until Trace Count displays 5/5.
61. Press the **Marker** soft key and then the **Peak Search** soft key.
62. Record the Marker M1 amplitude reading into the Measured Value column for 3275 MHz to 4123 MHz in [Table A-14](#) for MS2036C and in [Table A-35](#) for MS2038C.
63. Calculated the input related spurious level using the following formula:

$$\text{Input Related Spurious dBc} = \text{Marker M1 Amplitude Reading} - \text{Amplitude Reading of 3273 MHz}$$

64. Record the calculated value into the Calculated IRS column for 3275 MHz to 4123 MHz in [Table A-14](#) for MS2036C and in [Table A-35](#) for MS2038C and verify that it is ≤ -60 dBc.

8000 MHz Input Related Spurious Check

65. Set the MG3692X output to 8000 MHz CW, with an RF output level of -30 dBm.
66. On the MS203xC VNA Master, press the **Freq** hard key and then the **Center Freq** soft key.
67. Enter 8000 and then press the MHz soft key to set Center Freq to 8000 MHz.
68. Press the **BW** hard key and then the **RBW** soft key.
69. Enter 1 and then press the kHz soft key to set RBW to 1 kHz.
70. Press the **VBW** soft key.
71. Enter 100 and then press the Hz soft key to set VBW to 100 Hz.
72. Wait until the Trace Count displays 5/5.
73. Press the **Marker** hard key and then the **Peak Search** soft key.
74. Record the Marker amplitude reading at 8000 MHz into [Table A-14](#) for MS2036C or into [Table A-35](#) for MS2038C.
75. Press the **Freq** hard key and then the **Start Freq** soft key.
76. Enter 7719 and then press the MHz soft key to set Start Freq to 7719 MHz.
77. Press the **Stop Freq** soft key.
78. Enter 7721 and press the MHz soft key to set Stop Freq to 7721 MHz.
79. Wait until Trace Count displays 5/5.
80. Press the **Marker** hard key and then the **Peak Search** soft key.
81. Record the Marker M1 amplitude reading into the Measured Value column for 7719 MHz to 7721 MHz in [Table A-14](#) for MS2036C or in [Table A-35](#) for MS2038C.

82. Calculated the input related spurious level using the following formula:

$$\text{Input Related Spurious dBc} = \text{Marker M1 Amplitude Reading} - \text{Amplitude Reading of 8000 MHz}$$

83. Record the calculated value into the Calculated IRS column for 7719 MHz to 7721 MHz in [Table A-14](#) for MS2036C and in [Table A-35](#) for MS2038C and verify that it is ≤ -60 dBc.

15000 MHz Input Related Spurious Check (For MS2038C Only)

84. Set the MG3692X output to 15000 MHz CW, with an RF output level of -30 dBm.

85. On the MS203xC VNA Master, press the **Freq** hard key and then the Center Freq soft key.

86. Enter 15000 and then press the MHz soft key to set Center Freq to 15000 MHz.

87. Wait until the Trace Count displays 5/5.

88. Press the **Marker** hard key and then the Peak Search soft key.

89. Record the Marker amplitude reading of 15000 MHz in [Table A-35](#), "Spectrum Analyzer Input Related Spurious (IRS) Signals" on page A-18.

90. Press the **Freq** hard key and then the Start Freq soft key.

91. Enter 14719 and then press the MHz soft key to set Start Freq to 14719 MHz.

92. Press the Stop Freq soft key.

93. Enter 14721 and press the MHz soft key to set Stop Freq to 14721 MHz.

94. Wait until Trace Count displays 5/5.

95. Press the **Marker** hard key and then the Peak Search soft key.

96. Record the Marker M1 amplitude reading into the Measured Value column for 14719 MHz to 14721 MHz in [Table A-35](#).

97. Calculated the input related spurious level using the following formula:

$$\text{Input Related Spurious dBc} = \text{Marker M1 Amplitude Reading} - \text{Amplitude Reading of 15000 MHz}$$

98. Record the calculated value into the Calculated IRS column for 14719 MHz to 14721 MHz in [Table A-35](#) and verify that it is ≤ -60 dBc.

3-8 Resolution Bandwidth Accuracy

The following test is used to verify the resolution bandwidth accuracy of the spectrum analyzer in VNA Master models MS2036C and MS2038C.

Equipment Required

- Synthesized Signal Generator, Anritsu Model MS3692X
- K(m) to N(f) Adapter, Anritsu Model 34RKNF50
- 10 MHz Reference Standard, Symmetricom Model Rubisource T&M
- N(m) to N(m) RF Coaxial Cable, Anritsu Model 15NN50-1.0B
- BNC(m) to BNC(m) Coaxial Cable (Quantity 2), Anritsu part number 2000-1627-R
- BNC Tee Adapter, BNC(m) to BNC(f)/BNC(f), Anritsu part number 3-2600-2
- N(f) to K(m) Adapter, Anritsu Model 34NFK50 (for MS2038C with Option 11 Only)

Procedure

1. Connect the BNC Tee Adapter to the output of the 10 MHz Reference Standard.
2. Connect the 10 MHz Reference to the Anritsu MG3692X Synthesized Signal Generator.
3. Connect the 10 MHz Reference to the **Ext Ref Input** connector of the MS203xC VNA Master.
4. Turn on the 10 MHz Reference Standard and the Anritsu MG3692X Synthesized Signal Generator.
5. Set the MG3692X RF output frequency to 1 GHz CW and level to -30 dBm.
6. Press the **On/Off** key to turn on the MS203xC VNA Master.
7. Press the **Shift** key and then the **Mode (9)** key. Use the rotary knob to highlight **Spectrum Analyzer**, and then press the **Enter** key to switch to Spectrum Analyzer mode.
8. Press the **Shift** key, the **Preset (1)** key, and then the **Preset** soft key to reset the instrument to the default starting conditions.
9. Press the **Shift** key and the **Sweep (3)** key, press the **Sweep Mode** soft key, and then press the **Performance** soft key to set the instrument to Performance Sweep mode.

Note Before continuing, allow a 30-minute warm up for the internal circuitry to stabilize.

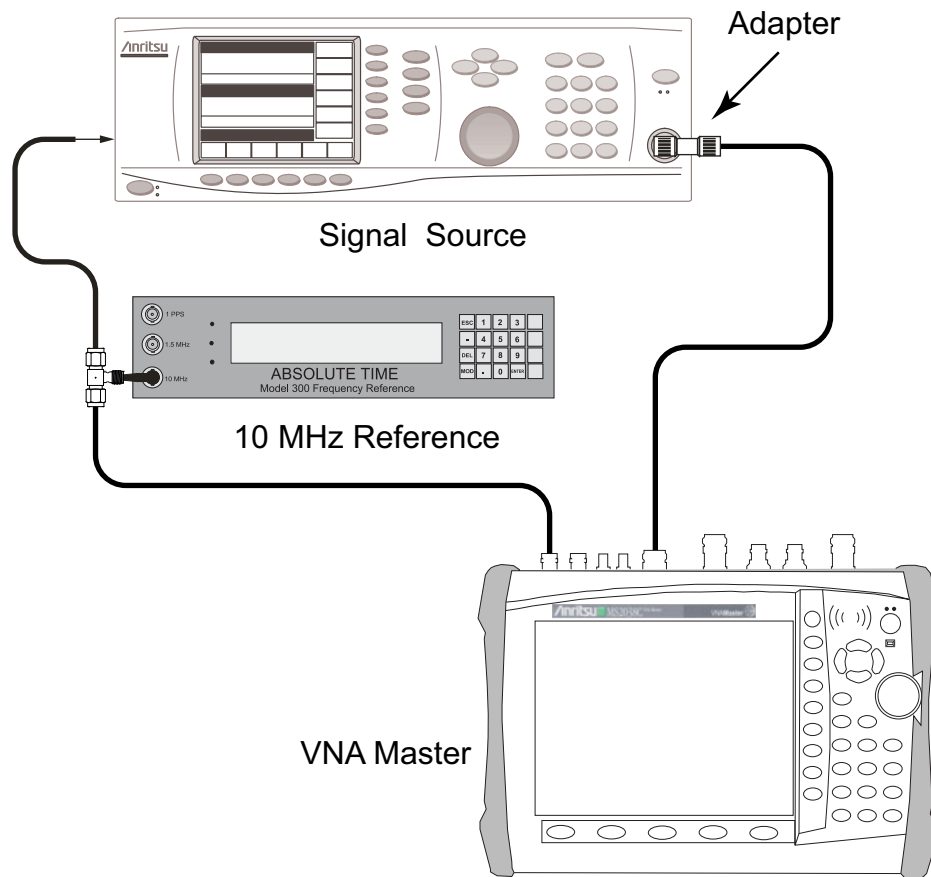

Figure 3-2. Resolution Bandwidth Accuracy Test

10. Connect the output of the Synthesized Signal Generator to the Spectrum Analyzer RF In connector of the MS203xC.
11. Press the **Amplitude** hard key and then the Reference Level soft key.
12. Enter -10 and then press the dBm soft key to set Reference Level to -10 dBm.
13. Press the Atten Lvl soft key.
14. Enter 0 and then press the dB soft key to set Atten Lvl to 0 dB.
15. Press the **Freq** hard key and then the Center Freq soft key.
16. Enter 1 and then press the GHz soft key to set Center Freq to 1 GHz.

RBW Test

17. Press the **Span** hard key.
18. Use the numeric keypad and the appropriate unit soft key (MHz, for example) to set Span to the first value that is listed in [Table A-15](#), “Spectrum Analyzer Resolution Bandwidth Accuracy” on page A-8 for MS2036C or in [Table A-36](#), “Spectrum Analyzer Resolution Bandwidth Accuracy” on page A-18 for MS2038C. Refer to the Span column of the Table.
19. Press the **BW** hard key and then the RBW soft key.
20. Use the numeric keypad and the appropriate unit soft key (for example, MHz) to set RBW to the first value listed in [Table A-15](#) for MS2036C or [Table A-36](#) for MS2038C in [Appendix A](#).
21. Press the VBW soft key.

22. Use the numeric keypad and the appropriate unit soft key (kHz, for example) to set VBW to the first value that is listed in [Table A-15](#) for MS2036C or in [Table A-36](#) for MS2038C.
23. Press the **Shift** key and then the **Measure (4)** key.
24. Press the OCC BW soft key
25. Ensure that the value in the dBc soft key is set to 3.
26. Press the OCC BW On/Off soft key to turn On occupied bandwidth measurement.
27. Record the OCC BW reading into the Measured Value column of [Table A-15](#) for MS2036C or of [Table A-36](#) for MS2038C.
28. Verify that the OCC BW frequency reading is within $\pm 10\%$ of the RBW setting.
29. Press the OCC BW On/Off soft key to turn Off occupied bandwidth measurement.
30. Repeat [Step 17](#) through [Step 29](#) for other settings and record the results into [Table A-15](#) for MS2036C or into [Table A-36](#) for MS2038C.

3-9 Amplitude Accuracy

The following tests are used to verify the amplitude accuracy of the spectrum analyzer in VNA Master models MS2036C and MS2038C. The tests are:

- “50 MHz Amplitude Accuracy Verification Procedure”
- “Amplitude Accuracy Across Frequency Verification Procedure”

Equipment Required

- 10 MHz Reference Standard, Symmetricom Model Rubisource T&M
- Synthesized Signal Generator, Anritsu Model MG3692X
- BNC(m) to BNC(m) Coaxial Cable (quantity 2), Anritsu part number 2000-1627-R
- BNC Tee Adapter, BNC(m) to BNC(f)/BNC(f), Anritsu part number 3-2600-2
- Dual Channel Power Meter, Anritsu Model ML2438A

For all units except MS2038C with Option 11

- High Accuracy Power Sensors (quantity 2), Anritsu Model SC7400
- Power Splitter, Aeroflex/Weinschel Model 1870A
- 10 dB Fixed Attenuator, Aeroflex/Weinschel Model 44-10
- N(m) to N(m) Adapter, Anritsu Model 34NN50A
- K(m) to N(f) Adapter, Anritsu Model 34RKNF50
- N(m) to N(m) RF Coaxial Cable, Anritsu Model 15NN50-1.0B

For MS2038C with Option 11 Only

- High Accuracy Power Sensors (quantity 2), Anritsu Model SC7413
- Power Splitter, Anritsu Model K241C
- 10 dB Fixed Attenuator, Anritsu Model 41KC-10
- K(m) to K(m) Adapter, Anritsu 33KK50B
- K(m) to K(f) RF Coaxial Cable, Anritsu Model 15KKF50-1.0A

50 MHz Amplitude Accuracy Verification Procedure

1. Refer to [Figure 3-3](#) and set up the test equipment as follows:
 - a. Connect both SC7400 (or SC7413) Power Sensors to the power meter, set the Power Meter to display both Channel A and Channel B, and then zero the power sensors.
 - b. Connect the BNC Tee Adapter to the output of the 10 MHz Reference Standard.
 - c. Connect the 10 MHz Reference Standard output to the Ext Ref Input connector of the MS203xC VNA Master.
 - d. Connect the 10 MHz Reference Standard output to the 10 MHz Ref In connector of the MG3692X Synthesized Signal Generator.
 - e. Connect the RF Coaxial Cable to the output of the MG3692X.
 - f. Connect the Power Splitter to the open end of the RF Coaxial Cable.
 - g. Connect Sensor B to one of the Power Splitter outputs.
 - h. Install the 10 dB Fixed Attenuator to the other Power Splitter output.
 - i. Connect Sensor A to the open end of the 10 dB Fixed Attenuator.

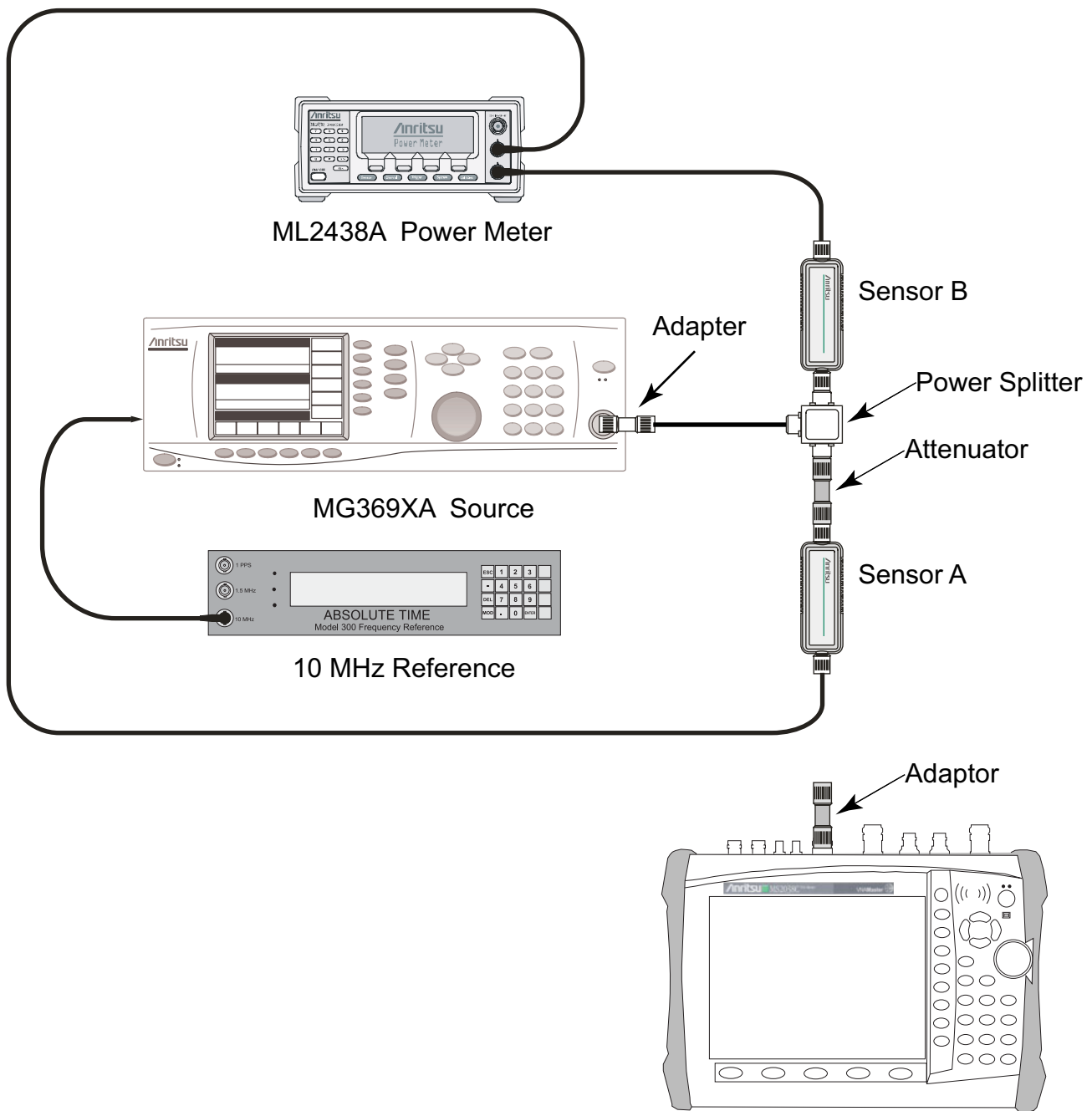

Figure 3-3. Amplitude Accuracy Verification Test Setup - Characterization

Caution In order to maintain test setup integrity, do not disconnect Sensor B, the Power Splitter, or the Fixed Attenuator.

Note Before continuing, allow a 30-minute warm up for the internal circuitry to stabilize.

2. Set the frequency of the MG3692X to 50 MHz CW.

3. On the Power Meter, press the **Sensor** key, the **Cal Factor** soft key, and then the **Freq** soft key. Use the keypad to enter the value matching the frequency of the MG3692X as the input frequency, which sets the power meter to the proper power sensor calibration factor. Repeat for Channel B. Press the **System** key to display the power reading.

Test Setup Characterization

4. Adjust the power level of the MG3692X to get a reading on Sensor A that matches the test power level in the first column of [Table A-16, “Spectrum Analyzer 50 MHz Amplitude Accuracy Setup Table” on page A-9](#) for MS2036C or of [Table A-37, “Spectrum Analyzer 50 MHz Amplitude Accuracy Setup Table” on page A-19](#) for MS2038C.
5. Record the Sensor B reading in the Required Sensor B Reading column of [Table A-16](#) for MS2036C or of [Table A-37](#) for MS2038C.
6. Repeat [Step 4](#) through [Step 5](#) for the other power levels in the first column of [Table A-16](#) for MS2036C or of [Table A-37](#) for MS2038C, and record the Sensor B readings in the second column.

Spectrum Analyzer 50 MHz Amplitude Measurements

Note	The Amplitude Accuracy specifications in the test record apply when the instrument is being verified in an environment between 20°C and 30°C after a 30 minute warm-up. For an instrument that is not being verified in a temperature controlled environment, but within a temperature range between –10°C and +50°C and after a 60 minute warm-up, add ± 1 dB to the Amplitude Accuracy specification.
-------------	---

7. Disconnect Sensor A from the 10 dB Fixed Attenuator.
8. Install the 34NN50A (or 33KFKF50B) adapter to the 10 dB Fixed Attenuator and then connect the open end of the adapter to the Spectrum Analyzer RF In connector of the MS203xC. Refer to [Figure 3-4](#).

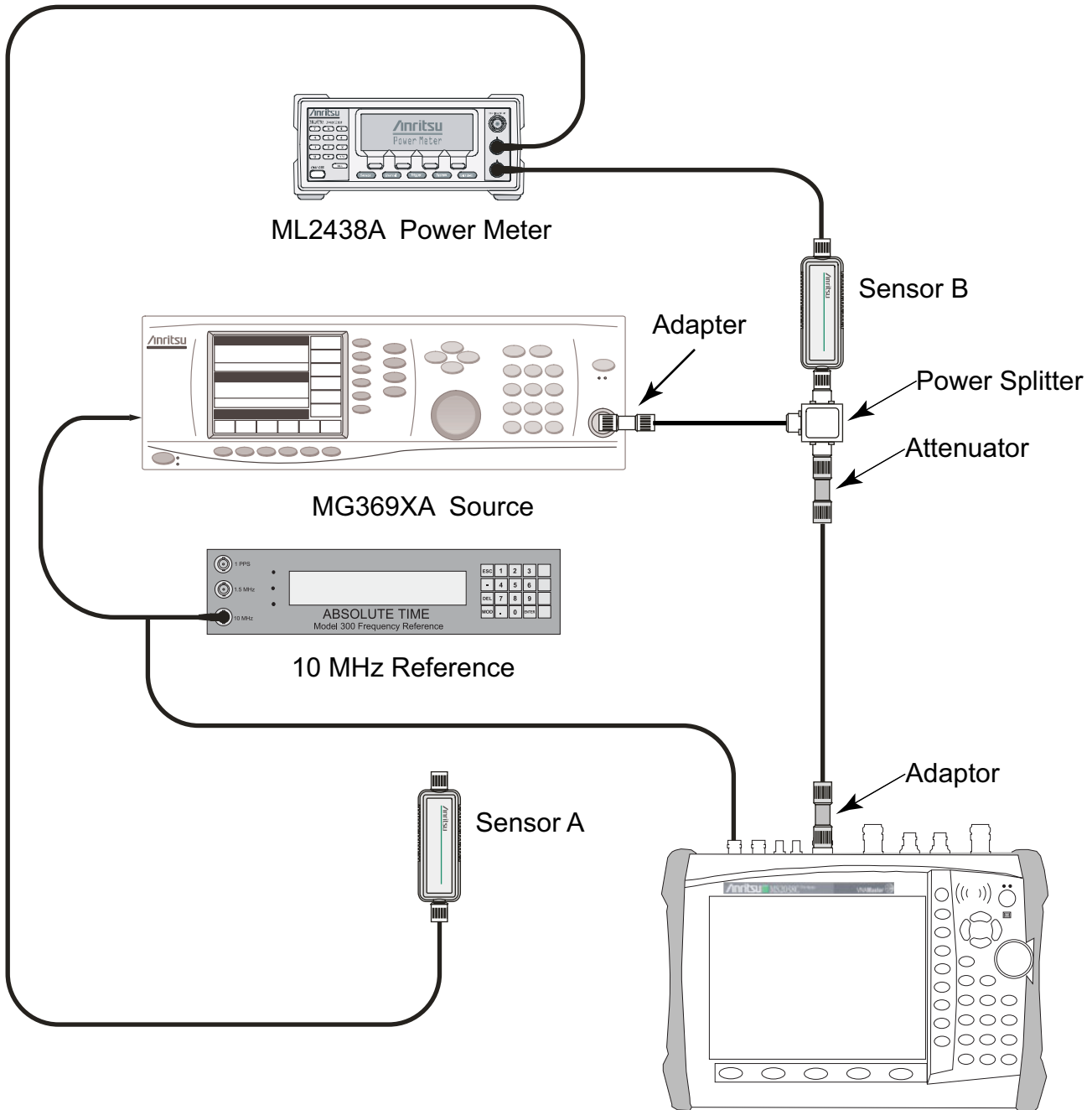

Figure 3-4. Amplitude Accuracy Verification Setup - Test Measurements

9. On the MS203xC, press the **Shift** key and then the **Mode (9)** key. Use the rotary knob to highlight Spectrum Analyzer, and then press the **Enter** key to switch to Spectrum Analyzer mode.
10. Press the **Shift** key, the **Preset (1)** key, and then the **Preset** soft key to reset the instrument to the default starting conditions.
11. Press the **Shift** key and the **Sweep (3)** key, press the **Sweep Mode** soft key, and then press the **Performance** soft key to set the instrument to Performance Sweep mode.
12. Press the **Amplitude** key and then the **Reference Level** soft key.
13. Enter 10 and then press the **dBm** soft key to set Reference Level to 10 dBm.

14. Press the **Atten Lvl** soft key.
15. Enter 30 and then press the **dB** soft key to set Atten Lvl to 30 dB.
16. Press the **Span** hard key.
17. Enter 10 and then press the **kHz** soft key to set Span to 10 kHz.
18. Press the **BW** hard key and then the **RBW** soft key.
19. Enter 1 and then press the **kHz** soft key to set RBW to 1 kHz.
20. Press the **VBW** soft key.
21. Enter 10 and then press the **Hz** soft key to set VBW to 10 Hz.
22. Press the **Freq** hard key and then the **Center Freq** soft key.
23. Enter 50 and then press the **MHz** soft key to set Center Freq to 50 MHz.
24. Adjust the power level of the MG3692X so that the Power Meter Sensor B reading matches the first Sensor B value (Required Sensor B Reading) in [Table A-16 on page A-9](#) for MS2036C or in [Table A-37 on page A-19](#) for MS2038C.
25. On the MS203xC, press the **Marker** hard key and then the **Peak Search** soft key.
26. Record the Marker M1 amplitude reading into the Measured Value column of [Table A-17, “Spectrum Analyzer 50 MHz Amplitude Accuracy” on page A-9](#) for MS2036C or of [Table A-38, “Spectrum Analyzer 50 MHz Amplitude Accuracy” on page A-19](#) for MS2038C.
27. Repeat [Step 24](#) through [Step 26](#) for the other power levels in [Table A-16](#) for MS2036C or in [Table A-37](#) for MS2038C. Change “Reference Level” and “Atten Lvl” setting as required (as shown in [Table A-17](#) for MS2036C or in [Table A-38](#) for MS2038C).
28. Calculate the Deviation values of each Test Level using the following formula:
$$\text{Deviation} = \text{Test Level} - \text{Measured Value}$$
29. Verify that the Deviation values are within specification.

Amplitude Accuracy Across Frequency Verification Procedure

1. Disconnect the Fixed Attenuator from the 34NN50A (or 33KFKF50B) Adapter.
2. Connect Sensor A back to the open end of the 10 dB Fixed Attenuator. Refer to [Figure 3-3](#).

Test Setup Characterization

3. Set the frequency of the MG3692X to 10.1 MHz CW.
4. On the Power Meter, press the **Sensor** key, the **Cal Factor** soft key, and then the **Freq** soft key. Use the keypad to enter the value matching the frequency of the MG3692X as the input signal frequency, which sets the power meter to the proper power sensor calibration factor. Repeat for Channel B. Press the **System** key to display the power reading.
5. Adjust the power level of the MG3692X so that the Sensor A reading is $-2 \text{ dBm} \pm 0.1 \text{ dB}$.
6. Record the Sensor B reading in the Required Sensor B Reading for -2 dBm column of [Table A-18, “Spectrum Analyzer Amplitude Accuracy Across Frequency Setup Table” on page A-10](#) for MS2036C or of [Table A-39, “Spectrum Analyzer Amplitude Accuracy Across Frequency Setup Table” on page A-20](#) for MS2038C.
7. Adjust the power level of the MG3692X so that the Sensor A reading is $-30 \text{ dBm} \pm 0.1 \text{ dB}$.
8. Record the Sensor B reading in the Required Sensor B Reading for -30 dBm column of [Table A-18](#) for MS2036C or of [Table A-39](#) for MS2038C.
9. Repeat [Step 3](#) through [Step 8](#) for all of the frequencies that are listed in [Table A-18](#) for MS2036C or in [Table A-39](#) for MS2038C.

Spectrum Analyzer Amplitude Across Frequency Measurements

Note	The Amplitude Accuracy specifications in the test record apply when the instrument is being verified in an environment between 20°C and 30°C after a 30 minute warm-up. For an instrument that is not being verified in a temperature controlled environment, but within a temperature range between –10°C and +50°C and after a 60 minute warm-up, add ± 1 dB to the Amplitude Accuracy specification.
-------------	---

10. Disconnect Sensor A from the 10 dB Fixed Attenuator.
11. Connect the 10 dB Fixed Attenuator to the 34NN50A (or 33KFKF50B) adapter at the Spectrum Analyzer RF In connector of the MS203xC. Refer to [Figure 3-4](#).
12. Set the MG3692X frequency to 10.1 MHz.
13. Set the MG3692X output to –20 dBm.
14. Set the Power Meter to display Channel B. Press the **Sensor** key, the Cal Factor soft key, and the Freq soft key. Use the keypad to enter the value matching the frequency of the MG3692X as the input signal frequency, which sets the power meter to the proper power sensor calibration factor. Press the **System** key to display the power reading.
15. Adjust the power level of the MG3692X so that the Power Meter Sensor B reading matches the Sensor B value for –30 dBm (Required Sensor B Reading) in [Table A-18 on page A-10](#) for MS2036C or in [Table A-39 on page A-20](#) for MS2038C.
16. On the MS203xC, press the **Freq** hard key and then the Center Freq soft key.
17. Enter 10.1 and then press the MHz soft key to set Center Freq to 10.1 MHz.
18. Ensure that Span is still set to 10 kHz.
19. Press the **Amplitude** hard key and then the Reference Level soft key.
20. Enter –20 and then press the dBm soft key to set Reference Level to –20 dBm.
21. Press the Atten Lvl soft key.
22. Enter 0 and then press the dB soft key to set Atten Lvl to 0 dB.
23. Press the **Marker** hard key and then the Peak Search soft key.
24. Record the Marker M1 amplitude reading into the Marker M1 Reading column of [Table A-19, “Spectrum Analyzer Amplitude Accuracy Across Frequency – 10.1 MHz and 100 MHz” on page A-10](#) for MS2036C or of [Table A-40, “Spectrum Analyzer Amplitude Accuracy Across Frequency – 10.0 MHz and 100 MHz” on page A-21](#) for MS2038C.
25. Calculate the deviation by subtracting –30 dBm from the Marker M1 amplitude reading. Record the result into the Dev column of [Table A-19](#) for MS2036C or of [Table A-40](#) for MS2038C.
26. Verify the deviation value is within specification.
27. Repeat [Step 21](#) through [Step 26](#) for Atten Lvl of 5 dB, 10 dB, and 20 dB.
28. Adjust the power level of the MG3692X so that the Power Meter Sensor B reading matches the Sensor B value for –2 dBm (Required Sensor B Reading) in [Table A-18](#) for MS2036C or in [Table A-40](#) for MS2038C.
29. On the MS203xC, press the Amplitude key and then the Reference Level soft key.
30. Enter 10 and then press the dBm soft key to set Reference Level to 10 dBm.
31. Repeat [Step 21](#) through [Step 26](#) for Atten Lvl of 30 dB, 40 dB, 50 dB, and 60 dB.
32. Repeat [Step 12](#) through [Step 31](#) for other frequencies that are listed in [Table A-19 on page A-10](#) through [Table A-24 on page A-13](#) for MS2036C or in [Table A-40 on page A-21](#) through [Table A-51 on page A-26](#) for MS2038C.

3-10 Third Order Intercept (TOI)

The following test verifies the Third Order Intercept point (also known as TOI or IP3) of the spectrum analyzer in VNA Master models MS2036C and MS2038C.

Equipment Required

- 10 MHz Reference Standard, Symmetricom Model Rubisource T&M
- Synthesized Signal Generator (quantity 2), Anritsu Model MG3692X
- BNC(m) to BNC(m) Coaxial Cable (quantity 3), Anritsu part number 2000-1627-R
- BNC Tee Adapter, BNC(m) to BNC(f)/BNC(f), Anritsu part number 3-2600-2
- Dual Channel Power Meter, Anritsu Model ML2438A
- Power Sensor, Anritsu Model MA2442D
- Power Splitter, Aeroflex/Weinschel Model 1870A
- 2 dB Fixed Attenuator (quantity 2), Aeroflex/Weinschel Model 44-2
- 6 dB Fixed Attenuator (quantity 2), Aeroflex/Weinschel Model 44-6
- 20 dB Fixed Attenuator (quantity 2), Aeroflex/Weinschel Model 44-20
- N(m) to N(m) Adapter, Anritsu Model 34NN50A
- K(m) to N(f) Adapter (quantity 2), Anritsu Model 34RKNF50
- N(m) to N(m) RF Coaxial Cable (quantity 2), Anritsu Model 15NN50-1.0B
- N(f) to K(m) Adapter, Anritsu Model 34NFK50 (For MS2038C with Option 11 Only)

Procedure

1. Refer to [Figure 3-5](#) and set up the test equipment as follows:
 - a. Install the BNC Tee adapter to the 10 MHz Reference Standard and then use a BNC(m) to BNC(m) coaxial cable to connect the 10 MHz Reference Standard to the Ext Ref Input connector of the MS203xC VNA Master.
 - b. Use a BNC(m) to BNC(m) coaxial cable to connect the 10 MHz Reference Standard to the 10 MHz Ref In connector of the MG3692X Synthesized Signal Generator #1.
 - c. Use a BNC(m) to BNC(m) coaxial cable to connect the 10 MHz Ref Out connector of the MG3692X Synthesized Signal Generator #1 and to the 10 MHz Ref In connector of the MG3692X Synthesized Signal Generator #2.
 - d. Connect a 20 dB Fixed Attenuator to each arm of the Power Splitter.
 - e. Connect a 6 dB Fixed Attenuator to each of the 20 dB Fixed Attenuators.
 - f. Connect a 2 dB Fixed Attenuator to each the 6 dB Fixed Attenuators.
 - g. Install 34RKNF50 adapters to the RF Output connectors of both MG3692X instruments.
 - h. Connect N(m) to N(m) Coaxial RF Cables to the 34RKNF50 adapters at the outputs of the MG3692X instruments.
 - i. Connect the open ends of the RF cables to the open ends of the 2 dB Fixed Attenuators.
 - j. Turn on the 10 MHz Reference Standard, MG3692X Synthesized Signal Generators, Power Meter, and MS203xC VNA Master.
 - k. Install the 34NN50A Adapter to the Spectrum Analyzer RF In connector of the MS203xC. For an MS2038C with Option 11, install the 34NFK50 Adapter prior to installing the 34NN50A Adapter.

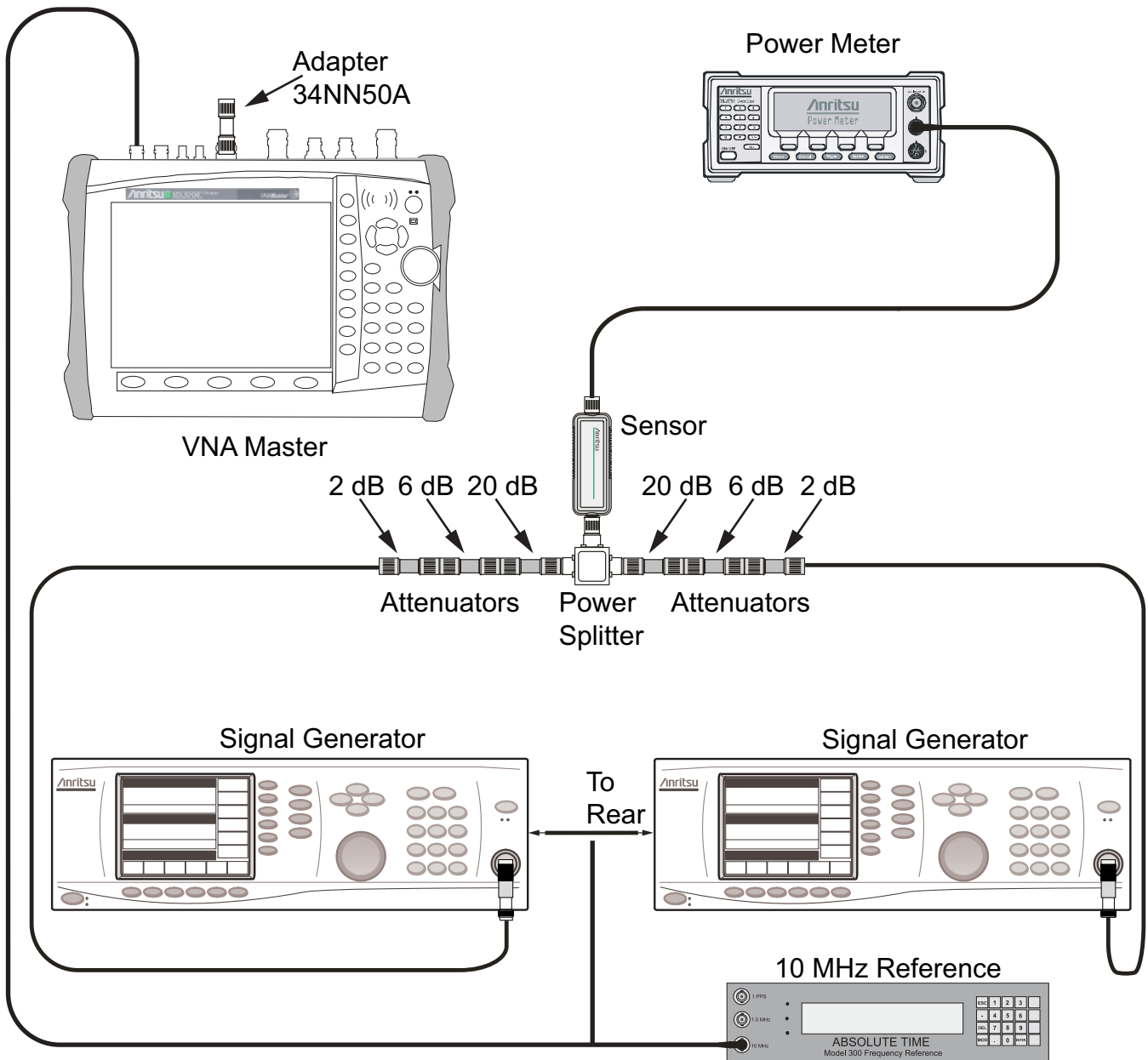

Figure 3-5. Third Order Intercept (TOI) Pre-test Setup

Note Before continuing, allow a 30-minute warm up for the internal circuitry to stabilize.

2. On the Power Meter, perform Zero/Cal on the Power Sensor. Press the **Sensor** key, the Cal Factor soft key, and the Freq soft key. Use the keypad to enter 2400 MHz as the input signal frequency, which sets the power meter to the proper power sensor calibration factor. Press the **System** key to display the power reading.
3. Set the MG3692X #1 to 2399.951 MHz CW, and the MG3692X #2 to 2400.051 MHz CW.
4. Turn Off MG3692X #2 RF.

5. Connect the Power Sensor to the Power Splitter input.

Note	The Power Splitter is being used as an RF combiner (the normal RF output ports become input ports, and the normal input port becomes the output port).
-------------	--

6. Adjust the output power of the MG3692X #1 until the Power Meter reads -20 dBm (approximately $+16$ dBm on the MG3692X).
7. Turn OFF MG3692X #1 RF.
8. Turn ON MG3692X #2 RF.
9. Adjust the output power of the MG3692X #2 until the Power Meter reads -20 dBm (approximately $+16$ dBm on the MG3692X).
10. Set up the MS203xC as follows:
 - a. Press the **Shift** key and then the **Mode (9)** key. Use the rotary knob to highlight Spectrum Analyzer, and then press the **Enter** key to switch to Spectrum Analyzer mode.
 - b. Press the **Shift** key, the **Preset (1)** key, and then the **Preset** soft key to reset the instrument to the default starting conditions.
 - c. Press the **Shift** key and the **Sweep (3)** key, press the **Sweep Mode** soft key, and then press the **Performance** soft key to set the instrument to Performance Sweep mode.
 - d. Press the **Amplitude** hard key and then the **Reference Level** soft key.
 - e. Enter -15 and then press the **dBm** soft key to set Reference Level to -15 dBm.
 - f. Press the **Atten Lvl** soft key.
 - g. Enter **0** and then press the **dB** soft key to set Atten Lvl to 0 dB.
 - h. Ensure that **Pre Amp On/Off** soft key is set to **Off**. If not, then press the **Pre Amp On/Off** soft key to turn Off the Pre Amp.
 - i. Press the **Detection** soft key.
 - j. Press the **RMS/Avg** soft key to set the instrument to RMS/Avg detection mode.
 - k. Press the **Span** hard key.
 - l. Enter 100 and then press the **Hz** soft key to set Span to 100 Hz.
 - m. Press the **BW** hard key and then the **RBW** soft key.
 - n. Enter 30 and then press the **Hz** soft key to set RBW to 30 Hz.
 - o. Press the **VBW** soft key.
 - p. Enter 1 and then press the **Hz** soft key to set VBW to 1 Hz.
 - q. Press the **Freq** hard key and then the **Center Freq** soft key.
 - r. Enter 2400.151 and then press the **MHz** soft key to set Center Freq to 2400.151 MHz.
11. Disconnect the Power Sensor from the Power Splitter.
12. Connect the open port of the Power Splitter to the 34NN50A Adapter that is installed at the MS203xC Spectrum Analyzer RF In connector. Refer to [Figure 3-6](#).

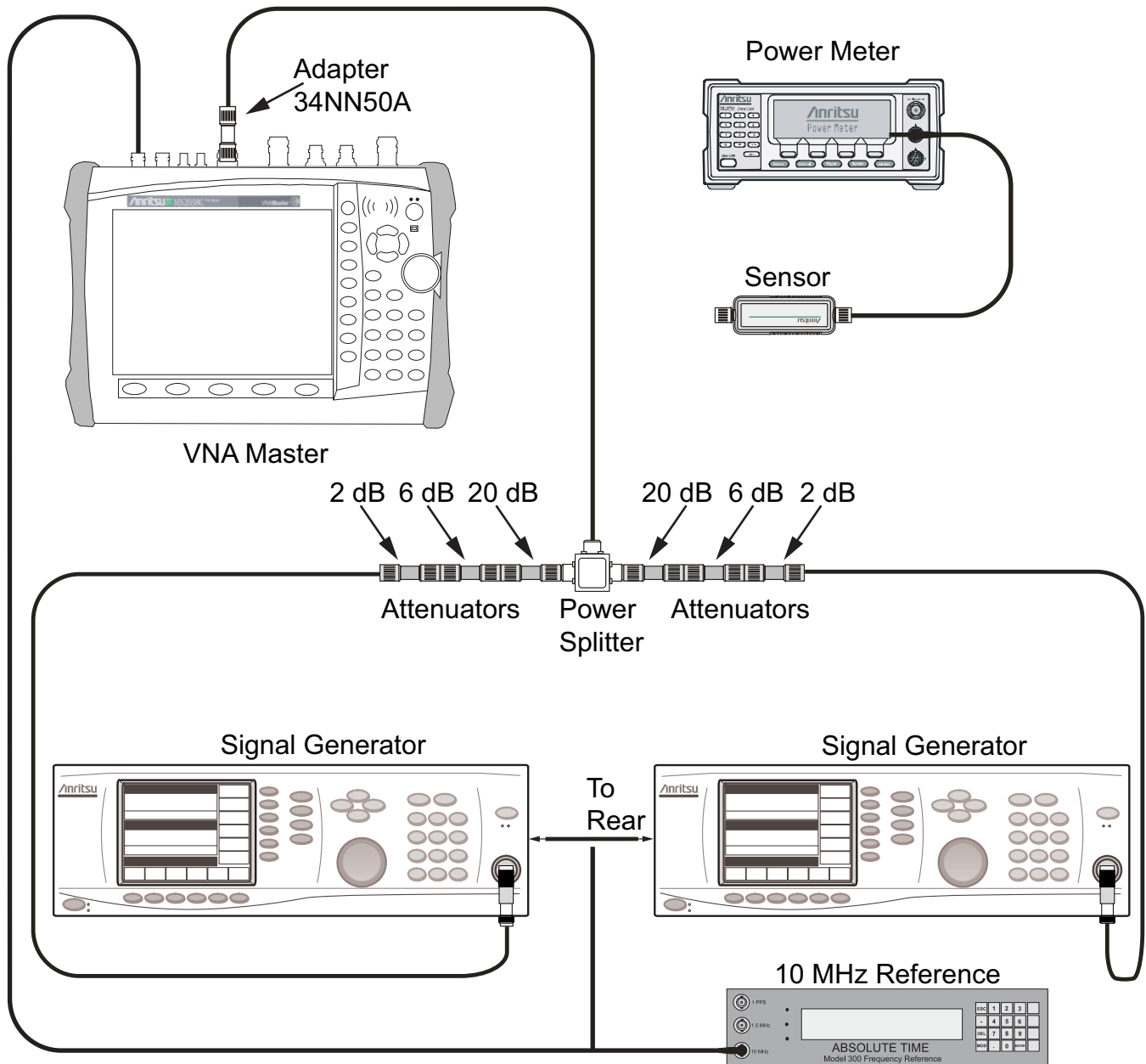

Figure 3-6. Third Order Intercept Measurement Setup

13. Turn RF to ON on MG3692X #1.
14. On the MS203xC, press the **Shift** key and then press the **Trace (5)** key.
15. Press the Trace A Operations soft key and then the # of Averages soft key.
16. Enter 2 and then press the **Enter** key to set # of Averages to 2.
17. Wait until the Trace Count displays 2/2.
18. Press the **Marker** hard key and then the Peak Search soft key.
19. Record the Marker amplitude reading at 2400.151 MHz in [Table A-25, "Spectrum Analyzer Third Order Intercept" on page A-13](#) for MS2036C or in [Table A-52, "Spectrum Analyzer Third Order Intercept" on page A-27](#) for MS2038C.

20. Press the **Freq** hard key and then the **Center Freq** soft key.
21. Enter 2399.851 and then press the **MHz** soft key to set Center Freq to 2399.851 MHz.
22. Wait until the Trace Count displays 2/2.
23. Press the **Marker** hard key and then the **Peak Search** soft key.
24. Record the Marker amplitude reading at 2399.851 MHz in [Table A-25](#) for MS2036C or in [Table A-52](#) for MS2038C.
25. Determine which signal is larger (signal at 2399.851 MHz or signal at 2400.151 MHz). Use the larger value for “max” in the following formula to calculate the TOI value:

$$\text{TOI} = -20 + [(-20 - \text{max})/2] \text{ dBm}$$

Example Calculation:

Assume max = -90 dBm, then $\text{TOI} = -20 [(-20 - (-90))/2] = +15 \text{ dBm}$

26. Record the calculated value into the Calculated TOI column in [Table A-25 on page A-13](#) for MS2036C or in [Table A-52 on page A-27](#) for MS2038C.

Chapter 4 — Options Performance Verification

4-1 Introduction

This chapter provides the procedures for verifying the performance or the functionality of various options in the MS2026C, MS2028C, MS2036C, and MS2038C VNA Master. The test procedures consist of the following:

- “Power Monitor (Option 5) Verification” on page 4-1
- “Bias Tee (Option 10) Operational Check” on page 4-4
- “GPS (Option 31) Operational Check” on page 4-6
- “Spectrum Analyzer Frequency Accuracy with GPS On” on page 4-8

4-2 Power Monitor (Option 5) Verification

If the Power Monitor (Option 5) is installed in the MS2026C or MS2028C VNA Master, then the following test can be used to verify the accuracy of the power measurements.

Equipment Required

- Synthesized Signal Generator, Anritsu Model MG3692X with Option 2A and Option 4 (or Option 5)
- Power Meter, Anritsu Model ML2438A
- Power Sensor, Anritsu Model MA2442D
- RF Detector, Anritsu 560-7N50B
- Power Splitter, Aeroflex/Weinschel Model 1870A
- RF Coaxial Cable, Anritsu Model 15NN50-1.0B
- Adapter, Anritsu Model 34RKNF50

Procedure

1. Press the **On/Off** key to turn on the VNA Master.
2. Press the **Shift** key and the **Preset (1)** key, and then the **Preset** soft key to reset the instrument to the default starting conditions.
3. Press the **Shift** key and then the **Mode (9)** key. Select Power Monitor and press the **Enter** key.

Note Before continuing, allow a 30-minute warm up for the internal circuitry to stabilize.

4. Set the MG3692X output to 1.0 GHz CW.
5. Connect the Power Sensor to the Power Meter.
6. Zero and calibrate the Power Sensor.
7. Set the Power Sensor Cal Factor to 1 GHz.
8. Connect the MG3692X, Power Meter, Power Sensor, and RF Detector as shown in [Figure 4-1](#).

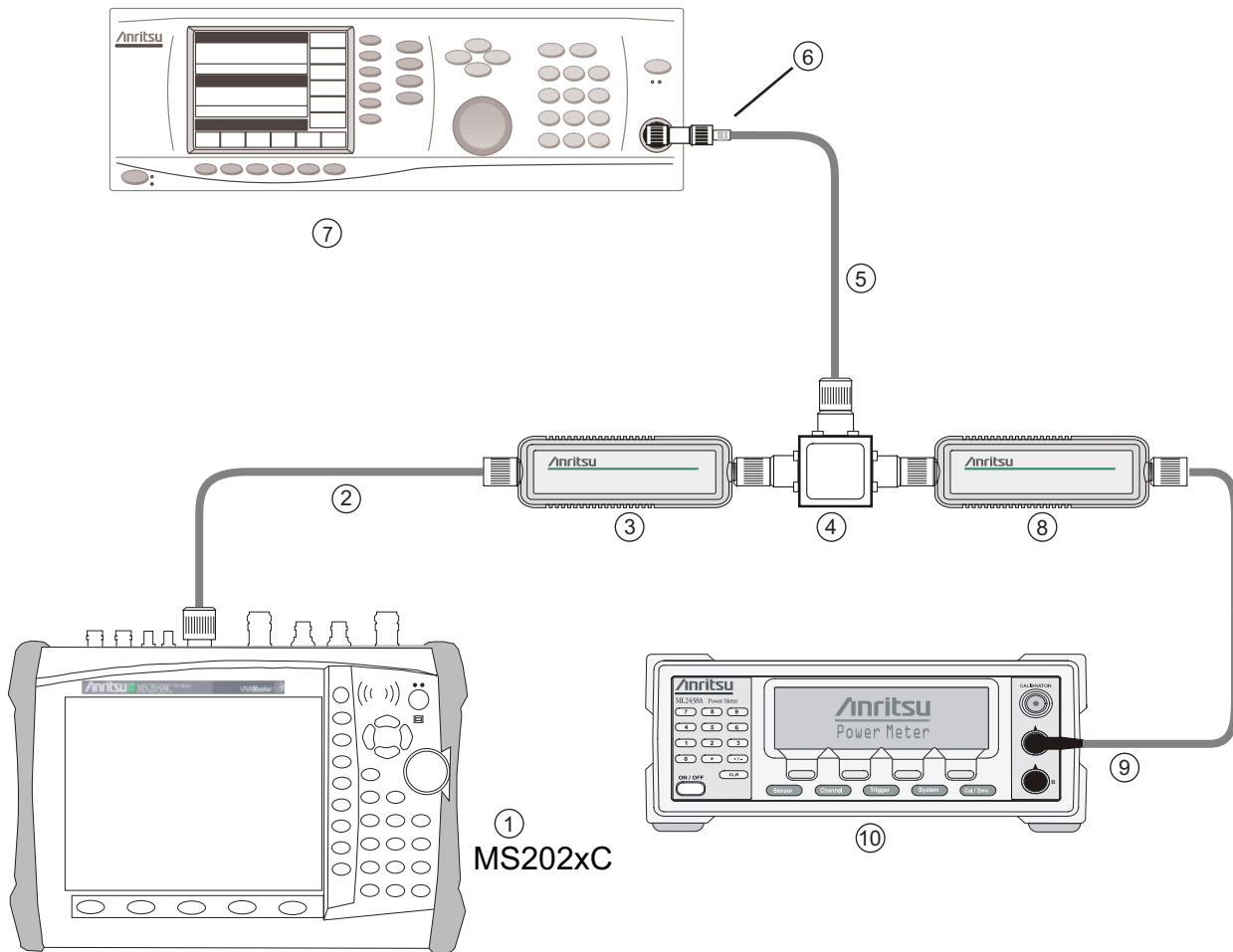

1. Anritsu MS2026C or MS2028C VNA Master
2. Detector Cable
3. Anritsu RF Detector, PN 560-7N50B
4. Power Splitter, Aeroflex/Weinschel Model 1870A
5. RF Coaxial Cable
6. Anritsu Adapter, PN 34RKNF50
7. Anritsu MS3692X Synthesized Signal Generator with Option A2 and Option 4 (or Option 5)
8. Anritsu Power Sensor, PN MA2442D
9. Power Sensor Cable
10. Anritsu ML243XA Power Meter

Figure 4-1. Power Monitor Verification Test Setup

9. On the MG3692X, press the **Level** key and then use the rotary knob to adjust the power level so that the power meter reads -40 dBm.
10. Verify that the VNA Master reading is within the specification shown in [Table 4-1 on page 4-3](#). Record the result to [Table A-2, “Power Monitor Measurement Accuracy” on page A-2](#) for MS2026C or to [Table A-4, “Power Monitor Measurement Accuracy” on page A-3](#) for MS2028C.

- Repeat [Step 9](#) and [Step 10](#) for the other power level settings that are shown in [Table 4-1](#).

Table 4-1. Power Monitor Verification Specifications

Power Level (dB)	Specification (dB)
-40	± 1.0
-21	± 1.0
-4	± 1.0
0	± 1.0
+13	± 1.0

4-3 Bias Tee (Option 10) Operational Check

If the Bias Tee (Option 10) is installed in the VNA Master, then the following test can be used to verify the internal bias tee functionality in the Vector Network Analyzer mode of MS2026C, MS2028C, MS2036C, or MS2038C.

Equipment Required

- 40 ohm, 5 watt, High Current Load, Anritsu T2904
- 78 ohm, 1 watt, Low Current Load, Anritsu T3536
- 105 ohm, 1 watt, Low Current Load, Anritsu T3377
- AC Power Adapter, Anritsu Part Number 40-168-R

Procedure

1. Connect the AC Power Adapter (Anritsu part number 40-168-R) to the VNA Master.

Note	The VNA Master must be powered by the AC Adapter for this test.
-------------	---

2. Press the **On/Off** key to turn on the VNA Master.
3. For an MS20xxC VNA Master, press the **Shift** key and then the **Mode (9)** key. Use the rotary knob to highlight Vector Network Analyzer, and then press the **Enter** key to switch to Vector Network Analyzer mode.
4. Press the **Shift** key, the **Preset (1)** key, and then the **Preset** soft key to reset the instrument to the default starting conditions.
5. Press the **Freq/Time/Dist** hard key and then press the **Start Freq** soft key.
6. Enter 10, then press the **MHZ** soft key to set the Start Frequency to 10 MHz.

Note	Before continuing, allow a 30-minute warm up for the internal circuitry to stabilize.
-------------	---

7. Press the **Measure** hard key and then the **S-Parameter** soft key. Select **S21** and press the **Enter** key to accept the selection.
8. Press the **Number of Traces** soft key and then press 1.
9. Press the **Maximize Active Trace** soft key.
10. Press the **Sweep** hard key, the **Configure Ports** soft key, and then the **Bias Tee Setup** soft key.
11. Press the **Int Port Selection** soft key to change to bias output to Port 1.

Voltage and Current Test

12. Connect the 105 ohm load to Port 1.
13. Ensure that the **Int Voltage P1** setting is 12.0 V.
14. Press the **Bias Tee** soft key and then the **Internal** soft key to turn On the Internal Bias Tee.
15. Verify that the voltage and current readings that are displayed in the upper-left corner of the screen are within the ranges shown in [Table 4-2](#).
16. Press the **Bias Tee** soft key and then the **Off** soft key to turn Off the Internal Bias Tee.
17. Press the **Int Voltage P1** soft key. Change the voltage to 18.0 V.
18. Repeat [Step 14](#) through [Step 16](#).
19. Remove the 105 ohm Load from Port 1, and connect the 78 ohm Load to Port 1.

20. Press the Int Voltage P1 soft key. Change the voltage to 32.0 V.
21. Repeat [Step 14](#) through [Step 16](#).

Table 4-2. Bias Tee Expected Voltage and Current

Voltage Setting (V)	12.0	18.0	32.0
Expected Voltage (V)	10 to 12	15.7 to 17.7	28.5 to 30.9
Expected Current (mA)	85 to 145	113 to 173	361 to 411

Fault Test

22. Remove the 78 ohm Load from Port 1 and connect the 40 ohm Load to Port 1.
23. Change Int Voltage P1 to 15.0 V.
24. Press the Bias Tee soft key and then the Internal soft key to turn On the Internal Bias Tee.
25. Verify that the instrument makes a clicking sound and the Bias Tee current reading displayed on the left side of the screen is **0 mA**.
26. Press the Bias Tee soft key and then the Off soft key to turn Off the Internal Bias Tee.
27. Repeat [Step 10](#) through [Step 26](#) for Port 2.

Note	<p>Helpful Tip:</p> <p>Set S Parameter to S12, set Int Port Selection to 2, change Int Voltage P2, and connect load to Port 2 as appropriate.</p>
-------------	---

4-4 GPS (Option 31) Operational Check

The following test is used to verify the operation of the GPS option in the Vector Network Analyzer mode of MS2026C, MS2028C, MS2036C, or MS2038C.

Equipment Required

- GPS Antenna, Anritsu part number 2000-1528-R or Trimble part number 57861-00
- SMA(m) to BNC(f) Adapter, Pomona part number 4290
- BNC(m) 93 ohm Terminator, Amphenol part number B1004A1-ND3G-93R-0.05-1W
- AC Power Adapter, Anritsu part number 40-168-R

Procedure

GPS Antenna Bias Tee Operational Check

1. Connect the SMA(m) to BNC(f) Adapter to the **GPS** connector of the VNA Master.
2. Connect the BNC(m) 93 ohm terminator to the BNC(f) end of the adapter.
3. Connect the external AC Power Adapter (Anritsu part number 40-168-R) to the VNA Master and then plug the power cord of the AC Power Adapter to an AC outlet.

Note	The VNA Master must be powered by external AC power for this test.
-------------	--

4. Press the **On/Off** key to turn on the VNA Master.
5. Press the **Shift** key, the **Preset (1)** key, and then the **Preset** soft key to reset the instrument to the default starting conditions.

Note	Before continuing, allow a 30-minute warm up for the internal circuitry to stabilize.
-------------	---

6. Press the **Shift** key, and then press the **System (8)** key.
7. Press the **GPS** soft key
8. Confirm that the 3.3 V setting on the **GPS Voltage** soft key is selected (underlined). If not, then press the soft key to toggle the setting to 3.3 V.
9. Press the **GPS On/Off** soft key to turn On GPS.
10. Press the **GPS Info** soft key and wait until the GPS INFO dialog box is displayed in the sweep window.
11. Verify that the GPS Antenna Current is within the expected current range for 3.3 V Bias in accord with [Table 4-3](#).

Table 4-3. GPS Antenna Bias Tee Operational Check

Voltage Setting	Expected Current Range
3.3 V	27 mA to 38 mA
5 V	42 mA to 64 mA

12. Press the **Esc** key to dismiss the GPS INFO dialog box.
13. Press the **GPS Voltage** soft key to toggle the setting to 5V.
14. Press the **GPS Info** soft key and wait until the GPS INFO dialog box appears.
15. Verify that the GPS Antenna Current is within the expected current range for 5 V Bias in accord with [Table 4-3](#).

16. Press the **Esc** key to dismiss the GPS INFO dialog box.
17. Press the GPS On/Off soft key to turn Off GPS.
18. Remove the adapter and terminator from the GPS Antenna connector of the VNA Master.

Note For the MS2036C and MS2038C, go to [Section 4-5 “Spectrum Analyzer Frequency Accuracy with GPS On”](#) on page 4-8.

GPS Receiver Operational Check (For MS2026C and MS2028C Only)

19. Connect the GPS Antenna to the GPS Antenna connector on the VNA Master.

Note Ensure that the Anritsu GPS Antenna is in a direct line-of-sight relationship to the GPS satellites or that the Antenna is placed outside without any obstructions.

20. Press the GPS On/Off soft key to turn On GPS.
21. When the GPS fix is acquired, the GPS indicator at the top of the screen turns green.

Note Acquiring satellites may take as long as three minutes. The GPS indicator turns green after at least three satellites has been tracked by the GPS receiver.

22. Press the GPS Info soft key to view the latitude, longitude, altitude, and other GPS information.

4-5 Spectrum Analyzer Frequency Accuracy with GPS On

The following test is used to verify the frequency accuracy of the spectrum analyzer with GPS On for the MS2036C and MS2038C.

Equipment Required

- 10 MHz Frequency Reference Standard, Symmetricom Model RubiSource T&M
- Synthesized Signal Generator, Anritsu Model MG3692X
- K(m) to N(f) Adapter, Anritsu Model 34RKNF50
- N(m) to N(m) RF Coaxial Cable, Anritsu Model 15NN50-1.0B
- BNC(m) to BNC(m) RF Coaxial Cable, Anritsu part number 2000-1627-R
- GPS Antenna, Anritsu part number 2000-1528-R or Trimble part number 57861-00
- N(f) to K(m) Adapter, Anritsu 34NFK50 (for MS2038C with Option 11 Only)

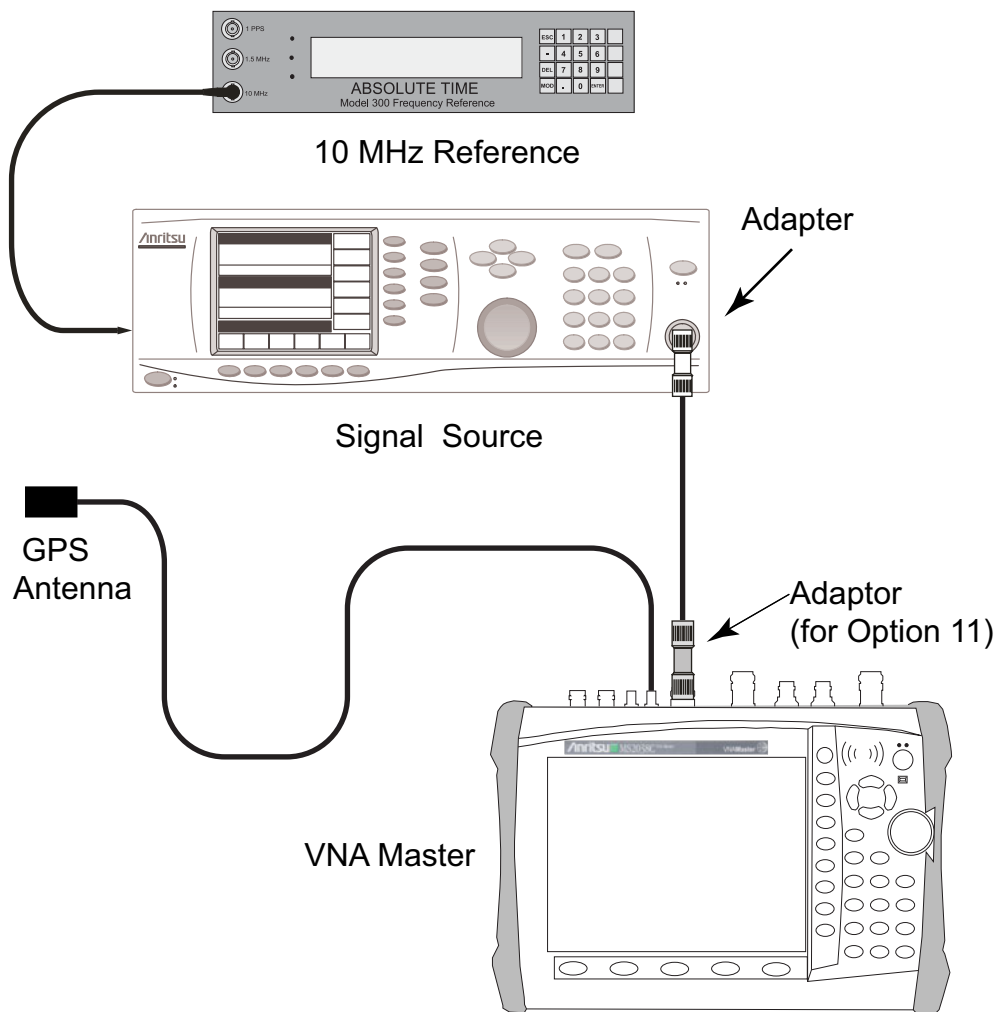

Figure 4-2. Spectrum Analyzer Frequency Accuracy with GPS On

Procedure

1. Connect the GPS Antenna to the GPS Antenna connector on the VNA Master..

Note	Ensure that the Anritsu GPS Antenna is in a direct line-of-sight relationship to the GPS satellites or that the Antenna is placed outside without any obstructions.
-------------	---

2. Connect the 10 MHz Reference to the Anritsu MG3692X Synthesized Signal Generator. Refer to [Figure 4-2](#)

Caution	Do not connect the 10 MHz Reference to the VNA Master.
----------------	--

3. Turn on the 10 MHz Reference Standard and the Anritsu MG3692X Synthesized Signal Generator.
4. Press the **On/Off** key to turn on the MS203xC VNA Master.
5. Press the **Shift** key and then the **Mode (9)** key. Use the rotary knob to highlight Spectrum Analyzer, and then press the **Enter** key to switch to Spectrum Analyzer mode.
6. Press the **Shift** key, the **Preset (1)** key, and then the Preset soft key to reset the instrument to the default starting conditions.
7. Press the **Shift** key and the **Sweep (3)** key, press the Sweep Mode soft key, and then press the Performance soft key to set the instrument to Performance Sweep mode.

Note	Before continuing, allow a 30-minute warm up for the internal circuitry to stabilize.
-------------	---

8. Set the MG3692X output to 7 GHz CW, with an RF Output Level of -30 dBm.
9. Connect the output of the Synthesized Signal Generator to the Spectrum Analyzer RF Input of the VNA Master.
10. On the MS203xC VNA Master, press the **Amplitude** hard key and then the Reference Level soft key.
11. Enter -10 and then press the dBm soft key to set Reference Level to -10 dBm.
12. Press the **Span** hard key and then the Span soft key.
13. Enter 10 and then press the kHz soft key to set Span to 10 kHz.
14. Press the **BW** hard key and then the RBW soft key.
15. Enter 100 and then press the Hz soft key to set RBW to 100 Hz.
16. Press the VBW soft key.
17. Enter 30 and then press the Hz soft key to set VBW to 30 Hz.
18. Press the **Freq** hard key and then the Center Freq soft key.
19. Enter 7 and then press the GHz soft key to set Center Frequency to 7 GHz.
20. Press the **Marker** hard key and then the More soft key.
21. Press the Counter Marker soft key to turn it **On**.
22. Press the Back soft key and then the Peak Search soft key.
23. Record the marker frequency value into [Table A-11, "Spectrum Analyzer Frequency Accuracy with GPS On" on page A-6](#) for MS2036C or into [Table A-32, "Spectrum Analyzer Frequency Accuracy with GPS On" on page A-17](#) for MS2038C.
24. Verify that the deviation of the value is $< \pm 350$ Hz (± 50 ppb) from 7 GHz.

Chapter 5 — Battery Information and Replacement

5-1 Introduction

This chapter describes the removal and replacement procedures for the instrument battery. Illustrations (drawings or photographs) in this manual may differ slightly from the instrument that you are servicing, but the basic removal and replacement functions will remain as specified. The illustrations are meant to provide assistance with identifying parts and their locations.

5-2 Replaceable Parts and Assemblies

The following replaceable parts are related to the battery pack and power adapters. To ensure that the correct parts are provided, be sure to list the model number, the instrument serial number, and the installed options with the order. The installed options are listed on a label on the top of the VNA Master and can also be viewed in the System / Status display.

Table 5-1. Replaceable Battery Parts and Assemblies

Part Number	Description
61379-2	Battery Door – For all MS202xC instruments
3-67151-2	Battery Door – For all MS203xC instruments
40-168-R	AC to DC Power Adapter
633-44	Rechargeable Battery, Li-Ion
806-141	Automotive 12 Volt DC Adapter

5-3 Battery Information

The following general information relates to the care and handling of the MS202xC or MS203xC VNA Master Rechargeable Lithium-Ion Battery, Anritsu Part Number 633-44.

Approved Batteries Only

- Always use the battery only for its intended purpose.
- Use only Anritsu-approved battery packs. Some non-approved battery packs may fit into the VNA Master but are electrically incompatible and will not charge correctly.
- The battery can be charged and discharged hundreds of times, but it will eventually wear out.
- The battery may need to be replaced when the operating time between charging becomes noticeably shorter than normal.
- Never use a damaged or worn out charger or battery.

Recharging

- The battery pack that is supplied with the MS202xC or MS203xC VNA Master may need charging before you use it.
- Before using the VNA Master, the internal battery may be charged either in the VNA Master, by using the 40-168R AC Power Adapter, or in an automobile by using the 806-141-R Automotive 12 Volt DC Adapter.
- The battery can also be charged separately in the optional 2000-1374 Dual Battery Charger.
- Recharge the battery only in the VNA Master or in an Anritsu-approved charger.
- Do not charge batteries for longer than 24 hours. Overcharging may shorten battery life.

Analyzer Not In Use

- When the VNA Master or the charger is not in use, disconnect it from the power source.
- A fully charged battery will discharge itself over time if left unused.
- Temperature extremes affect the ability of the battery to charge. Allow the battery to cool down or warm up, as necessary, before use or charging.
- Discharge the battery from time to time to improve battery performance and battery life.
- Storing the battery in extremely hot or extremely cold places will reduce the capacity and lifetime of the battery.

Physical Handling of Batteries

- Never short-circuit the battery terminals.
- Do not drop, mutilate, or attempt to disassemble the battery.

Battery Disposal

- The battery can be charged and discharged hundreds of times, but it will eventually wear out.
- Batteries must be recycled or disposed of properly. Do not place batteries in household garbage.

Warning Do not dispose of batteries in a fire!

5-4 Battery Pack Removal and Replacement

This section provides instructions for the removal and replacing the VNA Master battery pack.

Note

Many of the procedures in this section are generic, and apply to many similar instruments. Photos and illustrations used here are representative and may show instruments other than the MS202xC/MS203xC VNA Master.

1. With the VNA Master laying flat, face up, on a stable surface, locate the **Battery Access Door**, as shown in [Figure 5-1, “Battery Access Door Location”](#).



1. MS2026C/MS2028C/MS2036C/MS2038C VNA Master
2. Battery Access Door Location at instrument bottom.

Figure 5-1. Battery Access Door Location

- Place a finger in the battery access door **notch** and push the door down towards the bottom of the instrument, as shown in [Figure 5-2, "Battery Access Door Notch"](#).

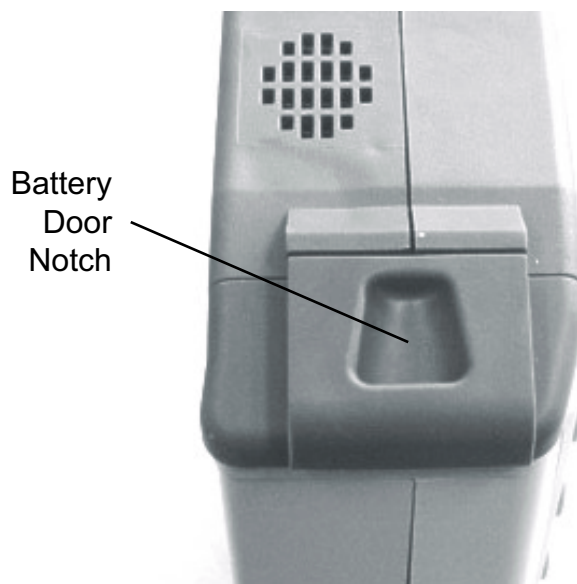

Figure 5-2. Battery Access Door Notch

- Remove the **Battery Access Door**, as shown in [Figure 5-3, "Removing the Battery Access Door"](#).

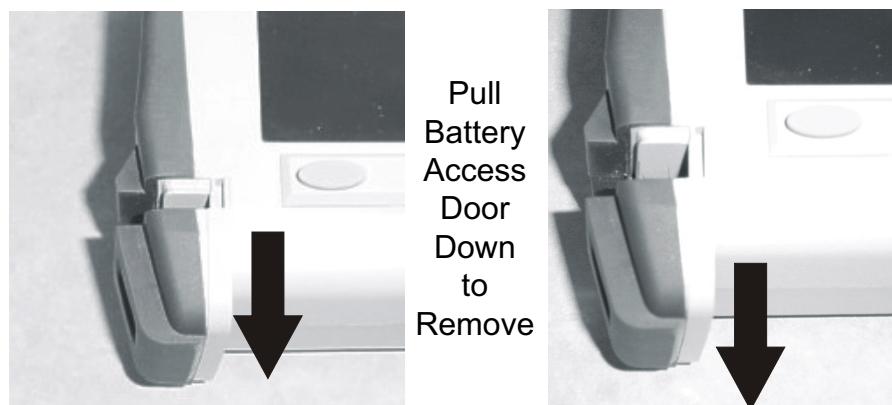

Figure 5-3. Removing the Battery Access Door

- The door may be reinstalled or replaced with a new door.

5. With the **Battery Access Door** completely removed, grasp the battery lanyard and pull the battery straight out of the unit, as illustrated in [Figure 5-4](#), “[Removing the Battery](#)”.
-



Figure 5-4. Removing the Battery



Figure 5-5. MS2026C/MS2028C/MS2036C/MS2038C Case, Battery Door, and Battery

6. Replacement is the opposite of removal. Note the orientation of the battery contacts, and be sure to insert the new battery with the contacts facing the bottom of the unit, as shown in [Figure 5-6](#), “Orientation of Battery Contacts”.

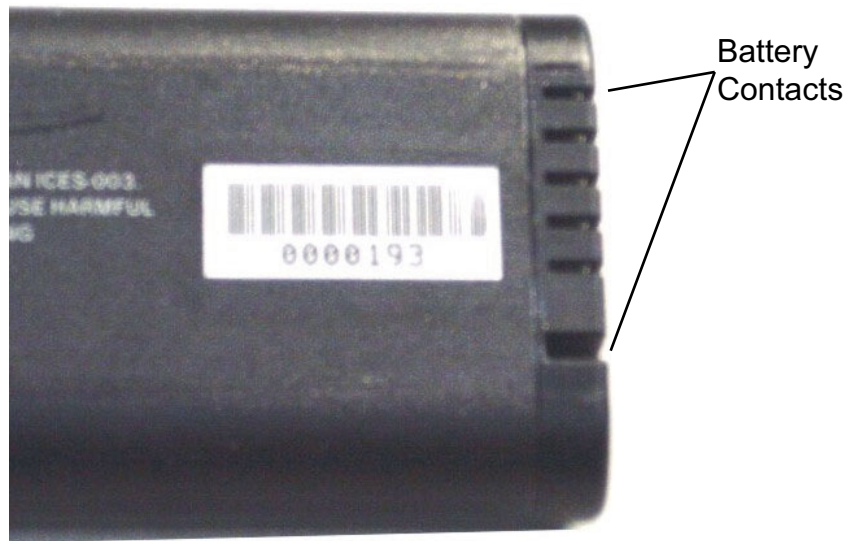

Figure 5-6. Orientation of Battery Contacts

Chapter 6 — Assembly Removal and Replacement, MS202xC

6-1 Introduction

This chapter describes the removal and replacement procedures for the various assemblies. Illustrations (drawings or photographs) in this manual may differ slightly from the instrument that you are servicing, but the basic removal and replacement functions will remain as specified. The illustrations are meant to provide assistance with identifying parts and their locations.

6-2 Electrostatic Discharge Prevention

An ESD safe work area and proper ESD handling procedures that conform to ANSI/ESD S20.20-1999 or ANSI/ESD S20.20-2007 is mandatory to avoid ESD damage when handling subassemblies or components found in the MS2026C or MS2028C VNA Master.

Warning	All electronic devices, components, and instruments can be damaged by electrostatic discharge. It is important to take preventative measures to protect the instrument and its internal subassemblies from electrostatic discharge.
----------------	---

6-3 Real Time Clock (RTC) Battery

Note	The Real Time Clock (RTC) battery is not field replaceable. The instrument must be returned to the factory for service.
-------------	---

6-4 Replaceable Parts, Assemblies, and Accessories

To ensure that the correct options are provided on the replacement assembly when ordering a Main PCB Assembly, all options that are installed on your instrument must be declared on the order. The installed options are listed on a label on the top of the MS202xC and can also be viewed in the System/Status display. For a list of replaceable parts, refer to [Table 1-7, “Replaceable Parts and Assemblies” on page 1-8](#).

6-5 Front Panel Components for VNA Master MS202xC

Figure 6-1 shows the major front panel components, including the bezels, keypad Rubber Membranes, PCBs, and other inner case components.

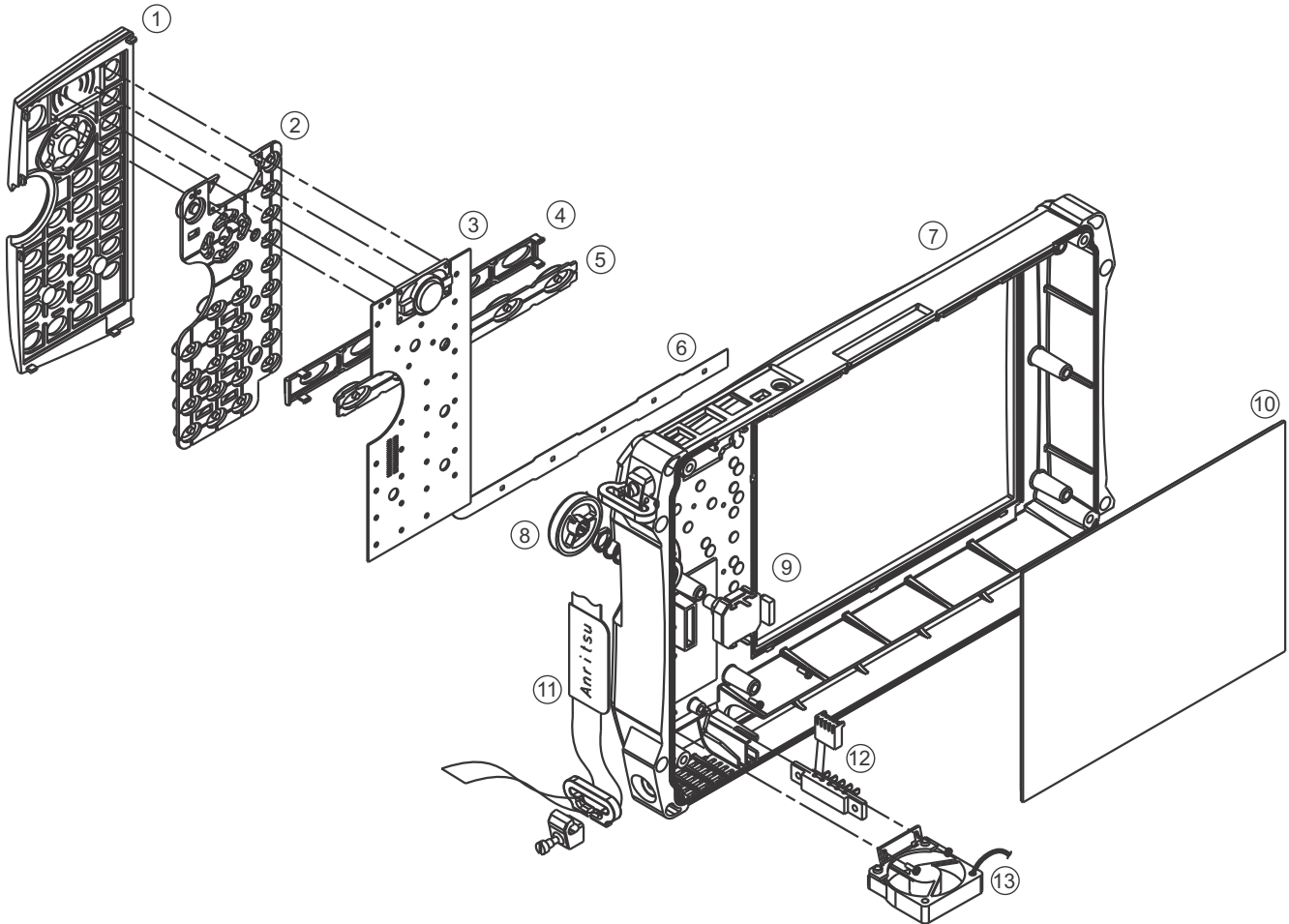

1. Main Keypad Switch Bezel
2. Main Keypad Switch Rubber Membrane
3. Main Keypad Switch PCB with installed speaker
4. Main Menu Keypad Switch Bezel
5. Main Menu Keypad Switch Rubber Membrane
6. Main Menu Keypad Switch Flex PCB connected to Main Keypad Switch PCB at J2
7. Case Front
8. Rotary Knob
9. Rotary Encoder with attached cable harness
10. LCD Clear Plastic Protector
11. Handle Carrying Strap
12. Battery Connector Contacts with attached cable harness
13. Cooling Fan with mounting bracket and attached cable harness.

Figure 6-1. Case Front Components Overview for MS202xC

6-6 Main Keypad Bezel for VNA Master MS202xC

Figure 6-2 shows the Main Keypad Bezel, the location of its locking tabs, and its relationship to the Main Keypad Rubber Membrane. The submenu keys (soft keys) are part of this keypad.

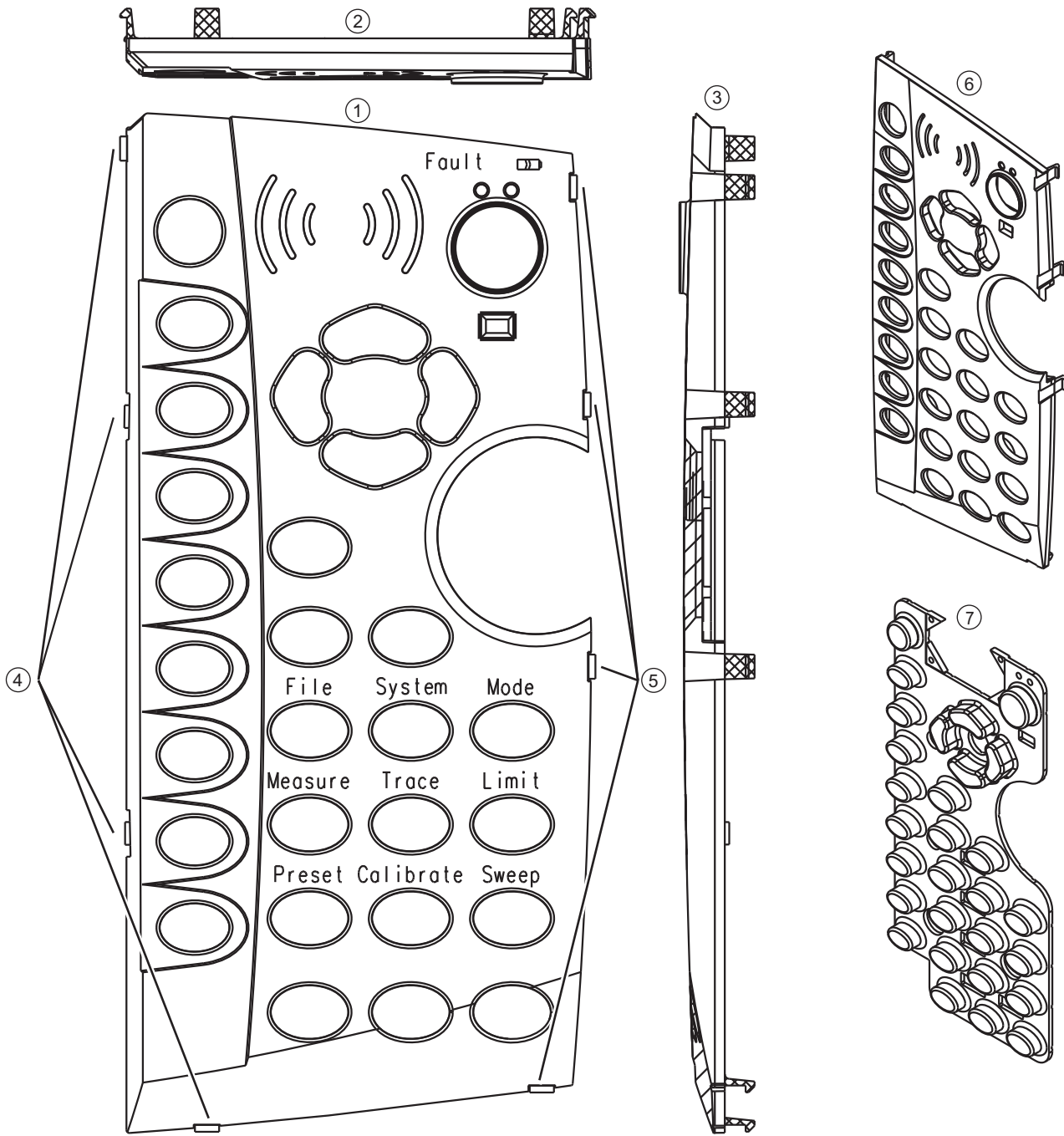

1. Main Keypad Bezel Front View
2. Top View
3. Side View
4. Left side locking tab locations
5. Right side locking tab locations
6. Three-Quarter View
7. Underlying Main Keypad Rubber Membrane

Figure 6-2. Main Keypad Bezel and Locking Tabs for MS202xC

6-7 Main Menu Keypad Bezel for VNA Master MS202xC

Figure 6-3 shows the Main Menu Keypad Bezel, the location of its locking tabs, and its orientation to the case. Note that 2 locking tabs are located at the left edge, 2 tabs are near the center, and 2 tabs are inset a short distance from the right edge. The Main Menu Keys may also be called Function Hard Keys.

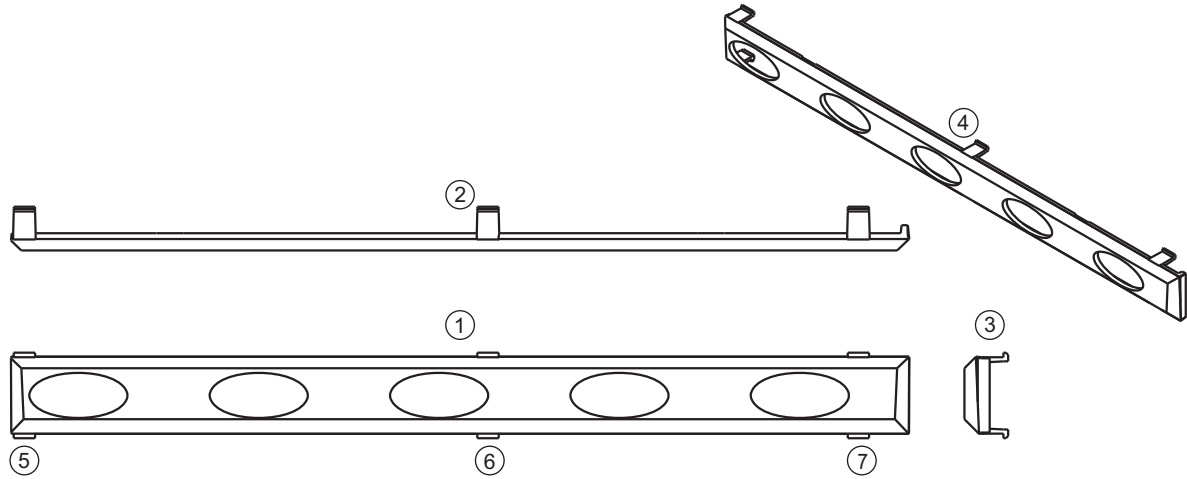

1. Main Menu Keypad Bezel Front View
2. Top View
3. Side View
4. Three-Quarter View
5. Locking tab location for the left end of the bezel, which goes toward the left side of the case
6. Locking tab location for bezel center
7. Locking tab location for the right end of the bezel, which goes toward the right side (handle side) of the case

Figure 6-3. Main Menu Keypad Bezel and Locking Tab Locations for MS202xC

6-8 Internal Anatomy of the VNA Master MS2026C

MS2026C View from Top Connector Strip

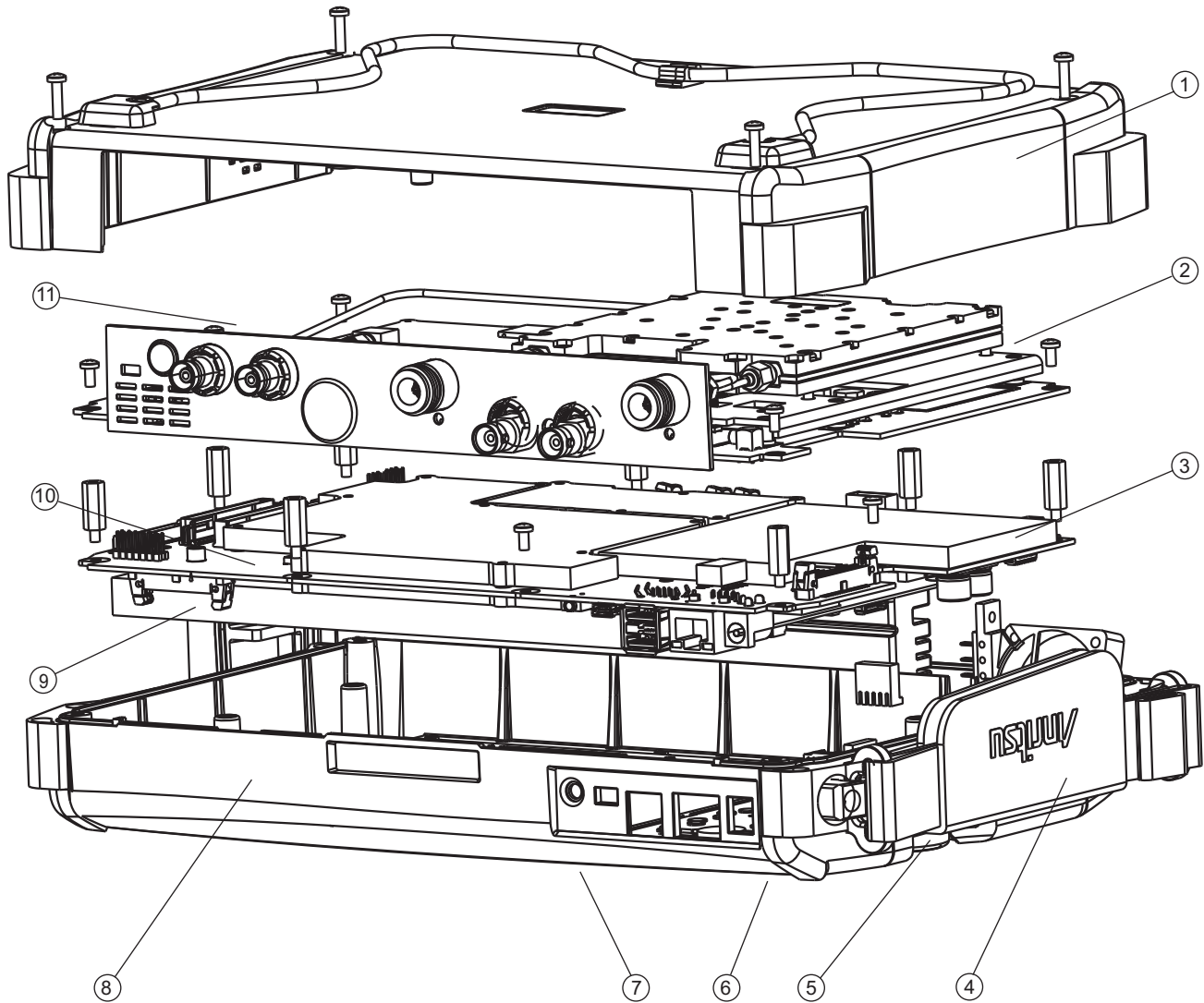

1. Case Back
2. VNA PCB Assembly with N(f) Connectors
3. Main PCB Assembly (mother board)
4. Hand Strap (mounted on Case Front)
5. Rotary Knob and Rotary Encoder (mounted on Case Front)
6. Main Keypad (mounted on Case Front)
7. Main Menu Keypad (mounted on Case Front)
8. Case Front
9. LCD Display (mounted on Main PCB Assembly)
10. GPS Module Option 31 PCB Assembly
11. Power Monitor Option 5 PCB Assembly (behind connector strip)

Figure 6-4. VNA Master MS2026C Major Assemblies – Viewed from Top Connector Strip

MS2026C View from Bottom

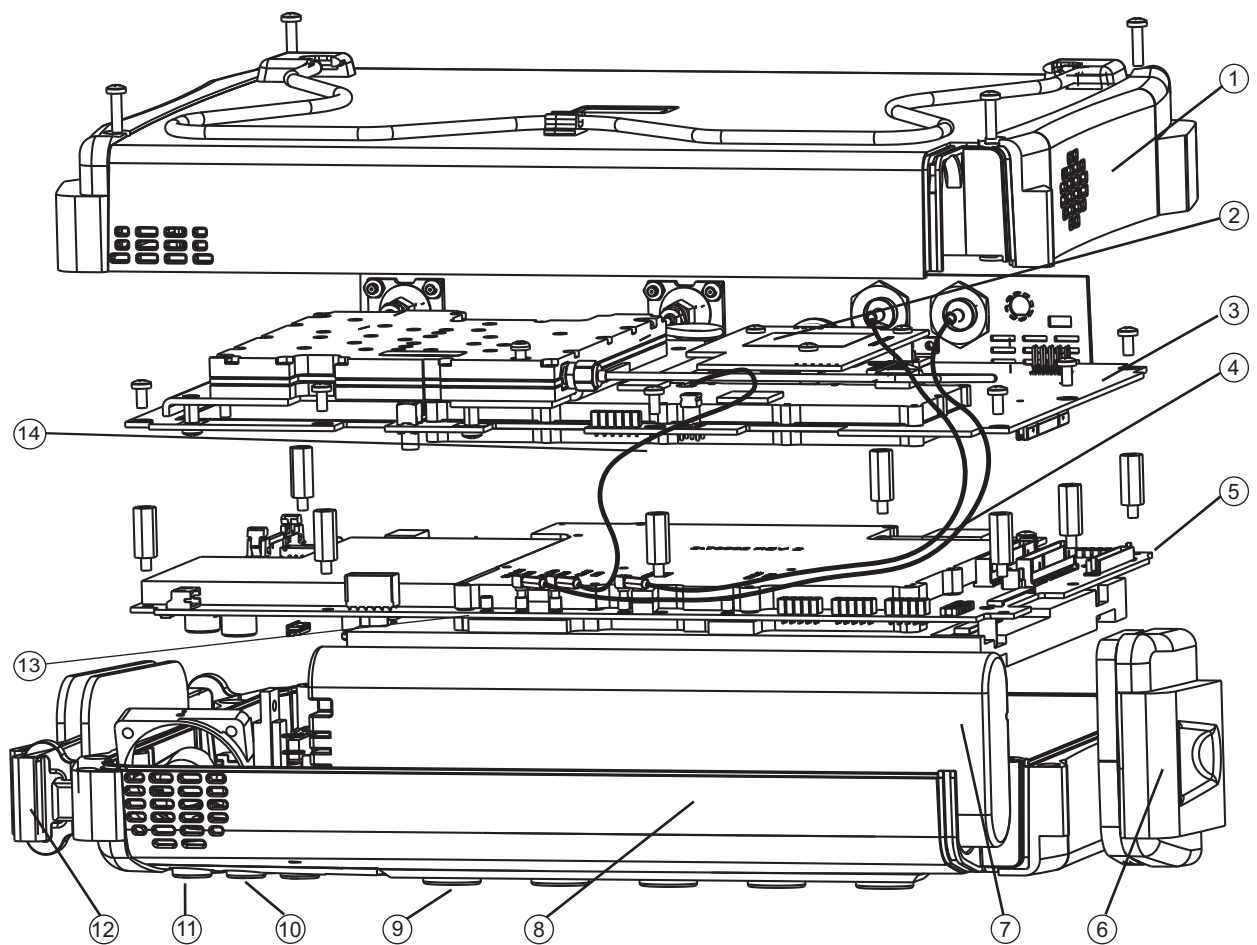

1. Case Back
2. Power Monitor Option 5 PCB Assembly (behind connector strip)
3. VNA PCB Assembly with N(f) Connectors
4. GPS Module Option 31 PCB Assembly
5. Main PCB Assembly (Mother Board)
6. Battery Door
7. Battery
8. Case Front
9. Main Menu Keypad (mounted on Case Front)
10. Numeric Keypad (mounted on Case Front)
11. Rotary Knob and Rotary Encoder (mounted on Case Front)
12. Hand Strap (mounted on Case Front)
13. LCD Display (mounted on Main PCB Assembly)
14. VNA cable to J2201 on Main PCB Assembly (Mother Board)

Figure 6-5. VNA Master MS2026C Major Assemblies – Viewed from Bottom

6-9 Internal Anatomy of the VNA Master MS2028C

MS2028C View from Top Connector Strip

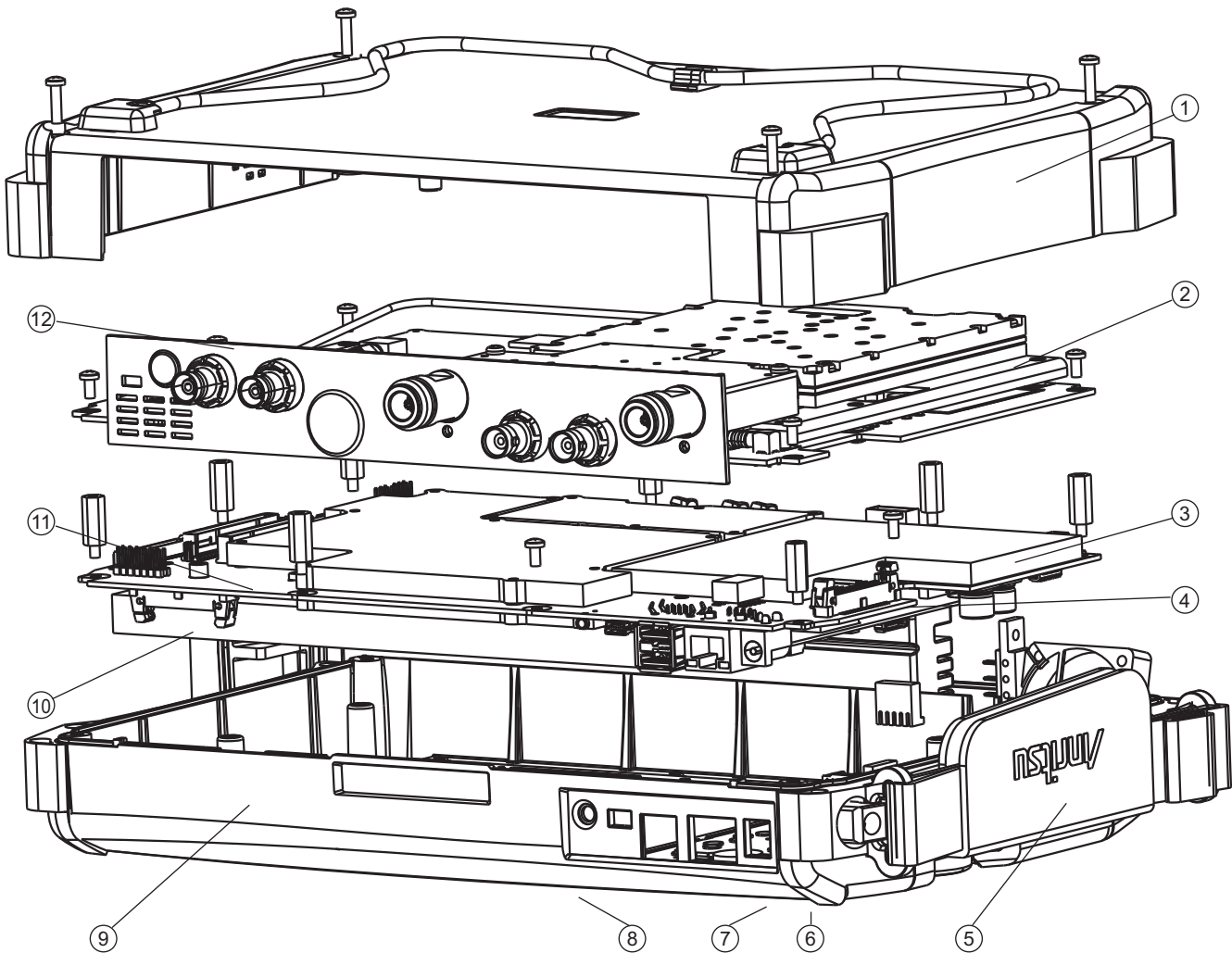

1. Case Back and Mounting Screws
2. VNA PCB Assembly with N(f) Connectors and Mounting Screws
3. Main PCB Assembly with Hex (m-f) Standoffs
4. LCD Backlight Cable Location (on Main PCB Assembly)
5. Hand Strap (mounted on Case Front)
6. Rotary Knob and Rotary Encoder (mounted on Case Front)
7. Main Keypad (mounted on Case Front)
8. Main Menu Keypad (mounted on Case Front)
9. Case Front
10. LCD Display (mounted on Main PCB Assembly)
11. GPS Module Option 31 PCB Assembly
12. Power Monitor Option 5 PCB Assembly (behind connector strip)

Figure 6-6. VNA Master MS2028C Major Assemblies – Viewed from Top Connector Strip

MS2028C View from Bottom

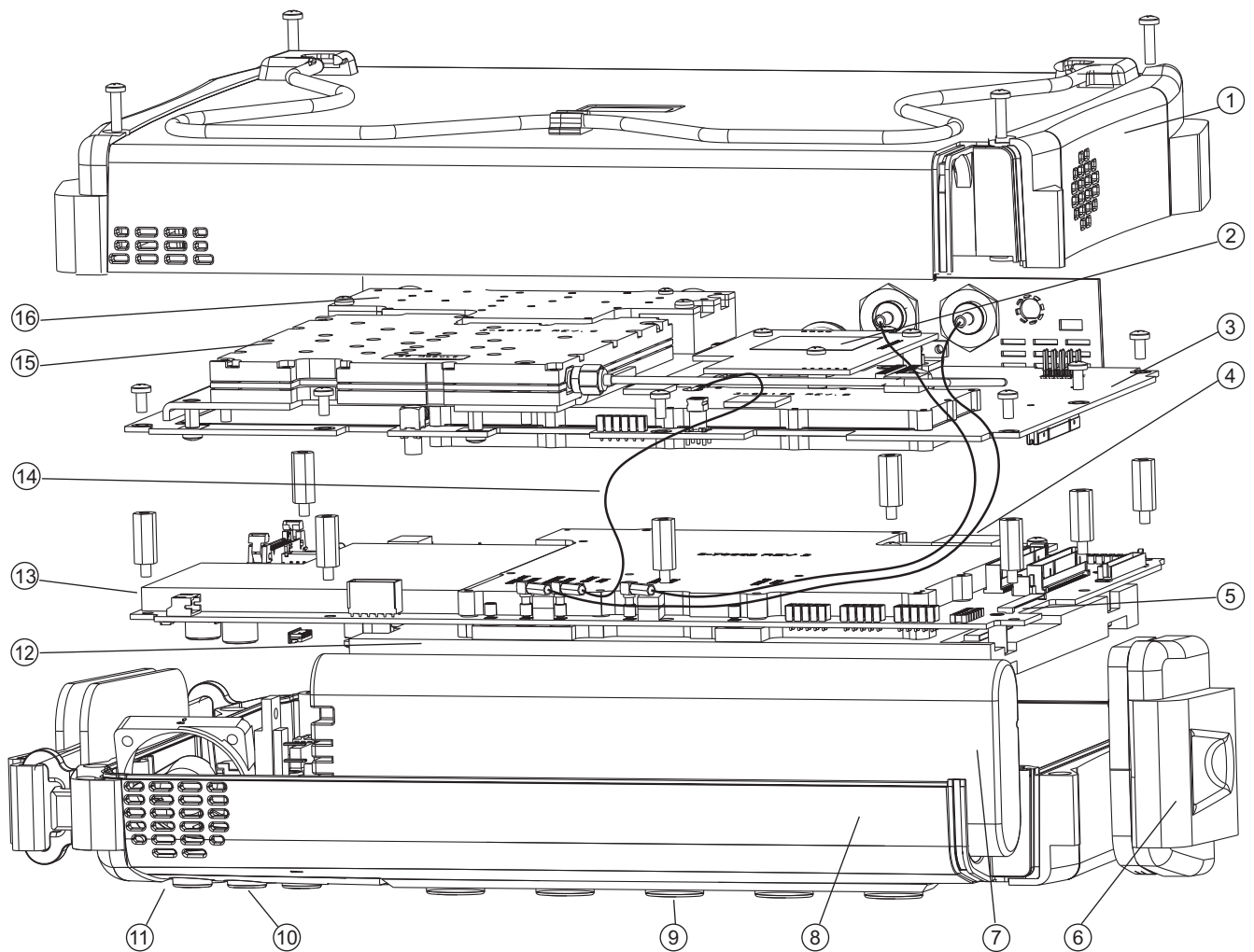

1. Case Back and Mounting Screws
2. Power Monitor Option 5 PCB Assembly (behind connector strip)
3. VNA PCB Assembly with N(f) or K(f) Connectors
4. GPS Module Option 31 PCB Assembly
5. LCD Backlight Cable Connector mounted on Main PCB Assembly)
6. Battery Door
7. Battery
8. Case Front
9. Main Keypad (mounted on Case Front)
10. Numeric Keypad (mounted on Case Front)
11. Rotary Knob and Rotary Encoder (not shown, mounted on Case Front)
12. LCD Display (mounted on Main PCB Assembly)
13. Main PCB Assembly
14. Cable, 26 MHz Reference (VNA Board to Mother Board)
15. RF Module Assembly
16. Microwave NF Module Assembly

Figure 6-7. VNA Master MS2028C Major Assemblies – Viewed from Bottom

6-10 Disassembly Sequence Overview

Outside Replacements

The following parts can be replaced without opening the case:

- Main Keypad Rubber Membrane
- Main Keypad PCB Assembly
- Main Menu Keypad Rubber Membrane
- Main Menu Keypad PCB Assembly
- Rotary Knob
- Hand Strap Handle
- Battery and Battery Door

Inside Replacements

Opening the instrument case provides access for the following replacement assemblies:

- Power Monitor PCB Assembly, Option 5
- VNA PCB Assembly
- GPS Receiver Module, Option 31
- Rotary Encoder
- Main PCB Assembly (Mother Board)
- LCD Display Assembly
- Clear Plastic LCD Protector

Overview of Replaceable Component Parts

The following steps reduce the VNA Master MS202xC (VNA only) to its replaceable component parts:

1. Remove the Battery Door and the Battery.
2. Remove the Handle Hand Strap.
3. Remove the Rotary Encoder Knob.
4. Remove the Main Menu Keypad Bezel, Membrane, and PCB.
5. Remove the Main Keypad Bezel, Membrane, and PCB.
6. Open the case and remove the Case Back Assembly
7. Remove the castellated BNC dress nut from the Ext Trig Input BNC connector on the top connector panel. Leave the BNC connector and its coaxial cable in place.
8. If the instrument is equipped with Power Monitor PCB Assembly (Option 005), then remove the Detector connector flex cable from the Power Monitor PCB. Remove the three screws and, protecting the underlying header pins, remove the Power Monitor PCB.
9. Disconnect the GPS Antenna SMA connector and cable from the top connector panel.
10. Remove the VNA PCB Assembly and the attached top connector panel.
11. Remove the Rotary Encoder from the case.
12. Disconnect the three (3) coaxial cables that are attached to the Main PCB Assembly
13. Remove the GPS Receiver Module PCB (Option 31) from the Main PCB Assembly.
14. Remove the Main PCB Assembly.
15. Flip the Main PCB Assembly over so that the LCD display is up, and remove the LCD Display Assembly from the Main PCB Assembly.
16. Remove the Clear Plastic LCD Protector from the Case Front.

6-11 Replacing Main Keypad Components – 3-61362, 3-71027-3

This procedure provides instructions for removing and replacing the Main Keypad Rubber Membrane and/or the underlying Main Keypad PCB. All keypad parts can be replaced without opening the MS202xC case.

Part Numbers

- 3-61362 – Main Keypad Rubber Membrane, for either MS2026C or MS2028C instruments
- 3-71027-3 – Main Keypad PCB, for either MS2026C or MS2028C instruments
- 3-61363-1 – Main Keypad Plastic Bezel
- 790-625 – Speaker

Procedure

Note Use a small piece of rubber or similar material as a fulcrum to prevent scratches to the front panel and the switch bezels.

1. Place the instrument face up on a protected work surface oriented with the top Connector Panel away from you.
2. Remove the Battery Door and the Battery.

Removing Rotary Knob:

3. Using a medium flat blade screwdriver, remove the Rotary Knob by sliding the screwdriver blade under the knob and levering it up gently.

Removing Main Keypad Bezel:

4. Eight (8) locking tabs hold the Main Keypad Bezel to the case as shown in [Figure 6-8](#).

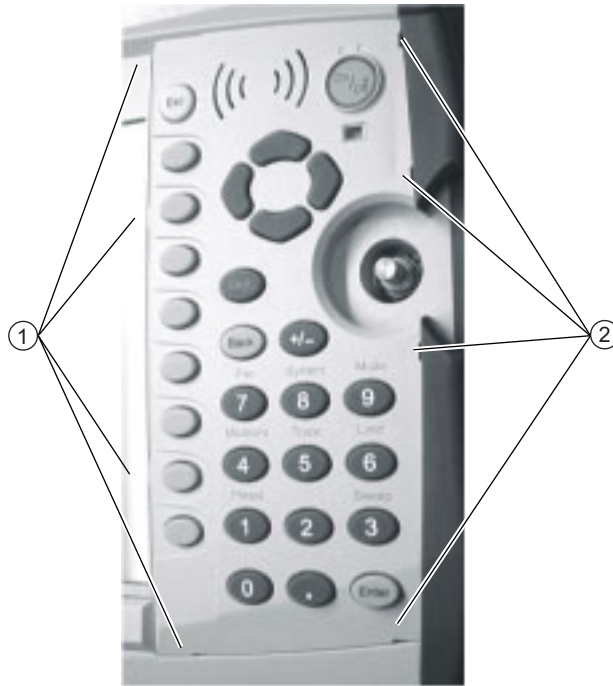

1. Location of Main Keypad Switch Bezel locking tabs, four (4) on left side
2. Location of four (4) locking tabs on right side

Figure 6-8. Main Keypad Bezel Locking Tab Locations

5. Using a small flat blade screwdriver and a piece of rubber as scratch protection, carefully pry the eight (8) Main Keypad Bezel locking tabs free of the main body of the case. The following tips help with the removal process:
 - The flat blade screwdriver width must be less than 3.5 mm (0.13 inch) wide and as thin as possible.
 - If available, recommended is a screwdriver made of fiberglass or other material that will not scratch the bezel.
 - As each locking tab releases, the bezel comes up a bit.
 - The basic technique is to position the protective piece of rubber (or similar material) next to the slot for scratch protection, press the screwdriver straight in between the case and the bezel, and then gently lever the screwdriver AWAY from the bezel.

Protecting Speaker and Remove Bezel:**Caution**

The Speaker sits on top of the Main Keypad PCB and is held in place by four locating pins on the inside of the keypad bezel around the speaker opening. When the keypad bezel is removed, the speaker is held only by the fragile connecting wires. Use extreme care not to damage the speaker wires when removing or replacing the keypad rubber membrane or the PCB.

6. When the eight locking tabs are released, then lift up the bezel carefully, disengage the speaker from its mounting pins (it stays attached to the underlying Main Keypad PCB), and set the bezel aside.

Removing Main Keypad Rubber Membrane:

7. Protecting the Speaker wires, start at the bottom of the Main Keypad Rubber Membrane and lift it up.
8. Hold the edge of the Speaker with one hand and gently remove the rubber Membrane from each side.

Replacement Options:

9. At this point, your options are to replace the Main Keypad Rubber Membrane, remove and replace the Main Keypad PCB, or to do both. Each procedure is described in the following sections.

If you are not replacing the Main Keypad PCB, then skip to [Step 19](#). If you are replacing the Main Keypad PCB, then continue with the next steps.

Removing Main Keypad PCB:

10. At the bottom left corner of the Main Keypad PCB, remove the drop of silicon sealant holding the ZIF SMT Flip Door connector shut. The narrow ribbon cable in the connector is the Main Menu Keypad Flex PCB.
11. Lift the connector cover open, and gently lift out the Main Menu Keypad Flex PCB. The Flex PCB stays in the case, but must be protected and kept out of the way for the following operations.

Caution Do not crimp, fold, or puncture the Main Menu Keypad Flex PCB.

12. Note that a 16-pin header connector is between the Main Keypad PCB and the Main PCB inside the case.
13. Protecting the speaker and its connections on the PCB, gently pry up the PCB as its header pins disconnect from the underlying Main PCB Assembly and set the Main Keypad PCB aside.

Replacing Main Keypad PCB:

14. The replacement PCB should come with an installed 16-pin header connector. The longer pins on the header go into the Main Keypad PCB. The short pins will ultimately connect through the front cover mounting slot into the Main PCB Assembly. Inspect the header pins to make sure that they are straight and evenly spaced.

If the 16-pin header connector is not included with the replacement PCB, then remove the existing 16-pin header from the old PCB and install it into the replacement unit. As stated, the long pins go into the Main Keypad PCB, and the short pins go through the case slot into the Main PCB (connector J5006).

15. Carefully position the replacement Main Keypad PCB on the case with the 16-pin header going into the case slot.
16. When the position is verified, and you are sure that the header is correctly located, gently press the PCB into place, making full contact with the Main PCB Assembly.
17. Open the connector Flip Latch in the lower left corner of the PCB at connector J2 and insert the Main Menu Keypad Flex PCB into the connector. Push the connector Flip Latch down and add a drop of RTV (Room Temperature Vulcanizing silicon sealant) to hold the door shut. Allow ample time for the sealant to set.

Anritsu Part Number: 3-783-1102 RTV Silicon Sealant

18. Either replace or reinstall the Main Keypad Rubber Membrane by following [Step 19](#) through [Step 23](#).

Replacing Main Keypad Rubber Membrane:

19. Starting at the bottom, lay in the replacement rubber Membrane.
20. At the top, lift up the left edge of the Speaker and lay in the rubber Membrane.
21. Again at the top, lift up the right edge of the Speaker and lay in the rubber Membrane.
22. When complete, the Speaker should sit on top of the rubber Membrane (the corners of the rubber Membrane are between the speaker and the Main Keypad PCB).
23. Make sure that the Main Menu Keypad ribbon cable is still securely connected at connector J2.

Installing Main Keypad Bezel:

24. Replace Main Keypad Bezel by first centering it on the rubber membrane and the Speaker. Note that 4 pins on the bezel engage with the 4 holes in the speaker frame.
25. Work your way around the bezel gradually positioning each Locking Tab partially into its slot. Take care not to bend any Locking Tab.
26. When all are correctly inserted, go around again snapping each tab into place.
27. When complete, each button should protrude approximately 1.5 mm to 2 mm above the bezel.

Installing Battery:

Refer to [Section 5-4 “Battery Pack Removal and Replacement”](#) on page 5-3.

28. Install the Battery.
29. Install the Battery Door.

Restarting the Instrument:

30. Restart the instrument.
31. Perform a function check for each button on the Main Keypad and the Main Menu Keypad.

6-12 Replacing Main Menu Keypad Rubber Membrane – 3-61361

This procedure provides instructions for removing and replacing the Main Menu Keypad Rubber Membrane, but not the Main Menu Keypad Flex PCB. All keypad parts can be replaced without opening the MS202xC case.

If the both the rubber membrane and the underlying Main Menu Keypad Flex PCB must be replaced, then the Main Keypad Bezel must also be removed. Use the procedure in [Section 6-13 “Replacing Main Menu Keypad Components”](#) on page 6-17

Part Numbers

- 3-61361 – Main Menu Keypad Rubber Membrane, for either MS2026C or MS2028C instruments

Procedure

Note Use a small piece of rubber or similar material (as a fulcrum) to prevent scratches to the front panel and the switch bezel.

1. Place the instrument face up on a protected work surface and oriented with the top Connector Panel away from you.
2. Remove the Battery Door and the Battery.

Removing Main Menu Keypad Bezel:

3. Six (6) locking tabs hold the Main Menu Keypad Bezel to the case as shown in [Figure 6-9I](#)

Caution Exercise extreme caution working around the LCD Display. Do not press in the middle of the display nor set any tools on it.

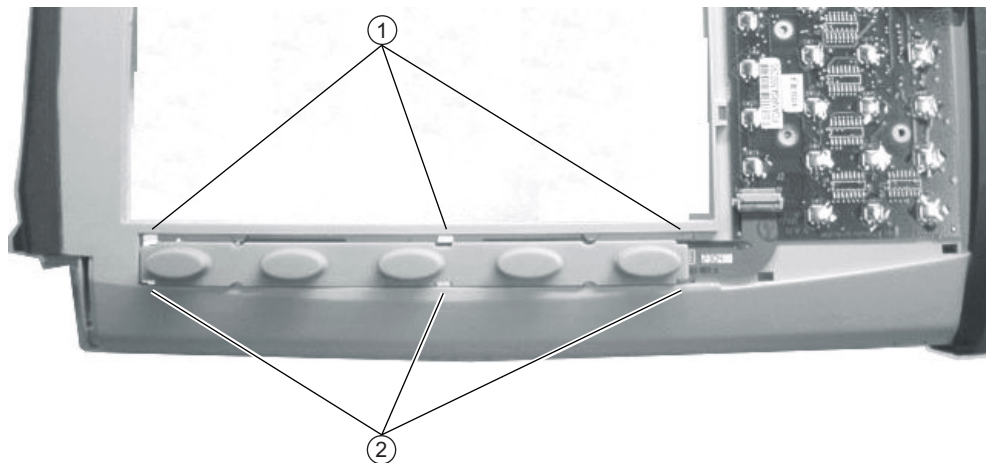

1. Location of three (3) upper locking tabs on the Main Menu Keypad Bezel.
2. Location of three (3) lower locking tabs.

Figure 6-9. Locking Tab Locations for Main Menu Keypad Bezel

4. Using a small flat blade screwdriver and a small piece of rubber or similar material as a fulcrum, carefully pry the six (6) Main Menu Keypad Bezel locking tabs free from the case. The following tips help with the removal process:
 - The flat blade screwdriver tip must be less than 3.5 mm (0.13 inch) wide and as thin as possible. If available, recommended is a screwdriver made of fiberglass or other material that will not scratch the bezel.
 - As each locking tab releases, the bezel comes up a bit.
 - The basic technique is to place the protective piece of rubber (or similar material) next to the slot, press the screwdriver straight in between the case and the bezel, and then gently lever the screwdriver AWAY from the bezel using the rubber as protection for the case finish.
5. When the six (6) locking tabs are released, lift up the bezel and set it aside.

Replacing Main Menu Keypad Rubber Membrane:

6. Lift the Main Menu Keypad Rubber Membrane out of the case and set it aside, revealing the underlying Main Menu Keypad Flex PCB.

Caution	Exercise extreme caution working around the Main Menu Keypad ribbon cable. Do not touch it with a screw driver or other tool.
----------------	---

7. Insert the replacement Main Menu Keypad Rubber Membrane into the case slot, making sure that the center Membrane latch cutouts correctly match up with the latch slots.

Installing Main Menu Keypad Bezel:

8. Replace the Main Menu Keypad Bezel by first correctly positioning it over its mounting slot, making sure that the latches at the very end of the bezel are to the left.
9. Work your way around the bezel gradually positioning each Locking Tab into its slot. Take care not to bend any Locking Tab.
10. When all tabs are correctly inserted, go around again snapping each tab into place.
11. When complete, each membrane button should protrude approximately 1.5 mm to 2 mm above the bezel.

Installing Battery:

Refer to [Section 5-4 “Battery Pack Removal and Replacement”](#) on page 5-3.

12. Install the Battery.
13. Install the Battery Door.

Restarting the Instrument:

14. Restart the instrument.
15. Perform a function check for each button on the Main Keypad.

6-13 Replacing Main Menu Keypad Components

3-61361, 3-71030-3, 3-61378-1

This procedure provides instructions for removing and replacing the Main Menu Keypad Plastic Bezel, the Main Menu Keypad Rubber Membrane, and the underlying Main Menu Keypad Flex PCB. The procedure steps are written with the assumption that the Main Keypad PCB will not be replaced. All keypad parts can be replaced without opening the MS202xC case. If only the Main Menu Keypad Rubber Membrane is to be replaced, then use the prior procedure in [Section 6-12 “Replacing Main Menu Keypad Rubber Membrane – 3-61361”](#) on page 6-15.

Part Numbers

- 3-61361 – Main Menu Keypad Rubber Membrane for either MS2026C or MS2028C instruments
- 3-71030-3 – Main Menu Keypad Flex PCB for either MS2026C or MS2028C instruments
- 3-61378-1 – Main Menu Keypad Plastic Bezel for either MS2026C or MS2028C instruments

Procedure

Note	Use a small piece of rubber or similar material to prevent scratches to the front panel and the switch bezel.
-------------	---

1. Place the instrument face up on a protected work surface oriented with the top Connector Panel away from you.
2. Remove the Battery Door and the Battery. Refer to [Chapter 5, “Battery Information and Replacement”](#).

Removing Rotary Knob:

3. Remove the Rotary Knob by using a medium flat blade screwdriver and a small piece of gasket or rubber as anti scratch material.
4. Slide the screwdriver under the Knob, and gently lever it the Knob up and off of its shaft.

Removing Main Keypad Bezel:

5. The Main Keypad Bezel and rubber Membrane must be removed to gain access to connector J2 on the Main Keypad PCB.

The Main Keypad PCB does not need to be removed to service the Main Menu Keypad assembly.

6. Eight (8) locking tabs hold the Main Keypad Bezel to the case as shown in [Figure 6-10](#).

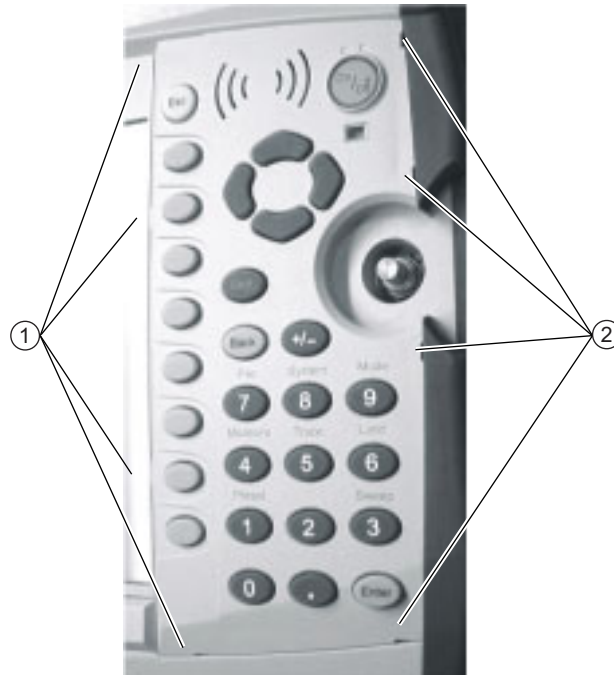

1. Location of four (4) left side locking tabs on the Main Keypad Switch Bezel.
2. Location of four (4) right side locking tabs.

Figure 6-10. Locking Tab Locations for Main Keypad Bezel

7. Using a small flat blade screwdriver and a small piece of rubber or similar material, carefully pry the eight (8) Main Keypad Bezel locking tabs free of the main body of the case. The following tips help with the removal process:
 - The flat blade screwdriver width must be less than 3.5 mm (0.13 inch) wide and as thin as possible. If available, recommended is a screwdriver made of fiberglass or other material that will not scratch the bezel.
 - As each locking tab releases, the bezel comes up a bit.
 - The basic technique is to place the protective piece of rubber (or similar material) next to the slot, press the screwdriver straight in between the case and the bezel, and then gently lever the screwdriver AWAY from the bezel using the rubber as protection for the case finish.

Protecting Speaker While Removing Bezel:

8. When the eight locking tabs are released, lift up the bezel carefully, disengage the speaker from its mounting pins (it stays attached to the underlying Main Keypad PCB), and set the bezel aside.

Note	The Speaker sits on top of the Main Keypad PCB and the keypad rubber membrane. It is held in place by four locating pins on the inside of the keypad bezel. When the keypad bezel is removed, the speaker is held only by the fragile connecting wires. Use care not to damage the speaker wires when removing or replacing the keypad rubber membrane or the PCB.
-------------	--

9. Protecting the Speakers wires, start at the bottom of the Main Keypad Rubber Membrane and lift it up.
10. Hold the edge of the Speaker with one hand and remove the Membrane from each side, exposing the Main Keypad PCB.

Removing Main Menu Keypad Bezel:

Caution	Exercise extreme caution working around the LCD Display. Do not press in the middle of the display nor set any tools on it.
----------------	---

11. Six (6) locking tabs hold the Main Menu Keypad Bezel to the case as shown in [Figure 6-9I](#)

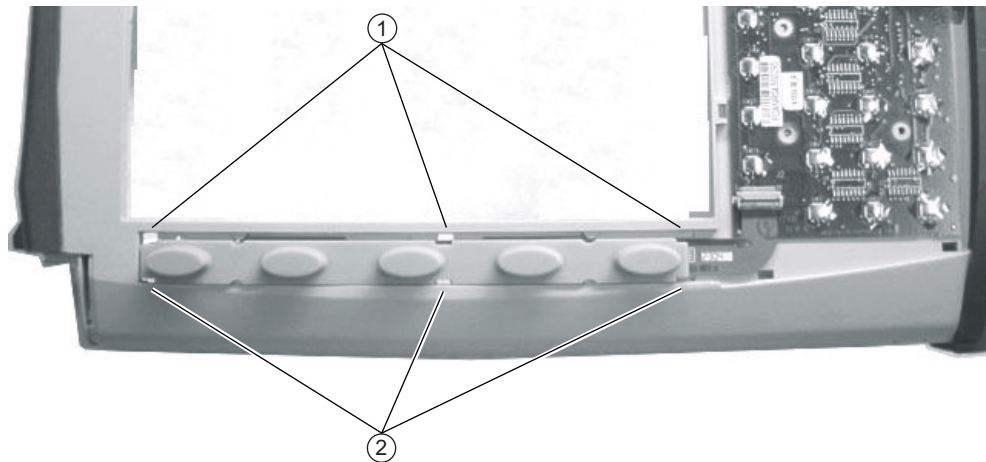

1. Location of three (3) upper locking tabs on the Main Menu Keypad Bezel (not shown) and the Keypad Rubber Membrane.
2. Location of three (3) lower locking tabs.

Figure 6-11. Locking Tab Locations for Main Menu Keypad Bezel

12. Using a small flat blade screwdriver and a small piece of rubber or similar material, carefully pry the six (6) Main Menu Keypad Bezel locking tabs free from the case. The following tips help with the removal process:
 - The flat blade screwdriver tip must be less than 3.5 mm (0.13 inch) wide and as thin as possible. If available, recommended is a screwdriver made of fiberglass or other material that will not scratch the bezel.
 - As each locking tab releases, the bezel comes up a bit.
 - The basic technique is to place the protective piece of rubber (or similar material) next to the slot, press the screwdriver straight in between the case and the bezel, and then gently lever the screwdriver AWAY from the bezel using the rubber as protection for the case finish.
13. When the six (6) locking tabs are released, lift up the bezel and set it aside.

Removing Main Menu Keypad Rubber Membrane and Flex PCB:

14. Lift the Main Menu Keypad Rubber Membrane out of the case and set it aside, revealing the underlying Main Menu Keypad Flex PCB.

Caution	Exercise extreme caution working around the Main Menu Keypad ribbon cable. Do not touch it with a screw driver or other tool.
----------------	---

15. The Main Menu Keypad Flex PCB is connected to the Main Keypad PCB by a ZIF (Zero Insertion Force) “Flip Lock” SMF connector (J2) on the Main Keypad PCB.
16. The Connector Flip Lock is held in place with a drop of silicon sealant.
17. Using a plastic or similar scraper, scrape the sealant off the connector. Then gently pry to the connector latch up, freeing the Main Menu Keypad Flex PCB.
18. Remove and set aside the old Main Menu Keypad Flex PCB.

Caution	The two keypad PCBs are fragile. Handle them with great care.
----------------	---

Replacing Main Menu Keypad Components:

19. Insert the replacement Main Menu Keypad Flex PCB into its slot.
20. Gently feed the right end of the Main Menu Flex PCB into the open Flip Lock connector and, when positioned correctly, snap the Lock into position.
21. Apply a drop of silicon sealant to the Flip Lock and the underlying Main Menu Keypad Flex PCB. The sealant drop should not protrude more than 2 mm above the top of the connector.
22. Allow ample time for the sealant to set before proceeding.
23. Insert the replacement Main Menu Keypad Rubber Membrane into the case slot, making sure that the Membrane correctly aligns with the ribbon cable.

Note that the membrane can go in only one way, with the center slots offset to the right.
24. Replace the Main Menu Keypad Bezel (new or used) making sure that it has the correct orientation.
 - The bezel end with two latches at the extreme end goes towards the left side of the instrument.
 - The bezel end with two inset latches goes toward the right side of the instrument.
25. Work your way around the bezel gradually getting each Locking Tab partially into its slot. Take care not to bend any locking tab.
26. When all are correctly inserted, go around again snapping each tab into place.
27. When complete, each Main Menu button should protrude approximately 1.5 mm to 2 mm above the bezel.

Installing Main Keypad Rubber Membrane:

28. Starting at the bottom of the Main Keypad, lay in the Main Keypad Rubber Membrane working towards the top.
29. At the top, lift up each edge of the Speaker and lay in the Membrane.
30. When complete, the Speaker should sit ON TOP of the rubber Membrane. The rubber membrane lies between the speaker and the PCB.
31. Make sure that the Main Menu Keypad ribbon cable is still securely connected.

Installing Main Keypad Bezel:

32. Replace the Main Keypad Bezel by first correctly positioning it over its mounting slot, making sure that the latches at the very end of the bezel are to the left.
33. Work your way around the bezel gradually positioning each Locking Tab partially into its slot. Take care not to bend any Locking Tab.
34. When all tabs are correctly inserted, go around again snapping each tab into place.
35. When complete, each membrane button should protrude approximately 1.5 mm to 2 mm above the bezel.

Installing Rotary Knob:

36. Install the Rotary Knob by pressing it onto the encoder shaft. The Knob has no specific orientation.

Installing Battery:

Refer to [Section 5-4 “Battery Pack Removal and Replacement” on page 5-3](#).

37. Install the Battery.
38. Install the Battery Door.

Restarting the Instrument:

39. Restart the instrument.
40. Perform a function check for each button on the Main Keypad and the Main Menu Keypad.

6-14 Replacing Hand Strap – 3-61470

This procedure provides instructions for replacing the right side Hand Strap using existing hardware. The case does not need to be opened for this procedure.

Part Numbers

- 3-61470 – Hand Strap

Procedure

1. Place the instrument face up on a protected work surface orientated with the top Connector Panel toward the right.
2. Using a flat blade screwdriver, remove the two M3 Slotted Screws holding the two Plastic Ring Holders to the case.
3. Orient the strap so that the word “Anritsu” reads correctly.
4. Capture one Handle End Ring with the Ring Holder and screw into place.
5. Making sure that the strap is not twisted, capture the remaining ring with the Ring Holder. and screw into place.

6-15 Replacing Rotary Knob – 3-61360-2

This procedure covers removing and replacing the Rotary Knob. The case does not need to be opened for this procedure. Note that this part does not include the Rotary Encoder. To replace the Rotary Encoder, refer to [Section 6-20 “Replacing Rotary Encoder – 3-410-101” on page 6-39](#)

Part Numbers

- 3-61360-2 – Rotary Knob
 - For either MS2026C or MS2028C instruments
 - **Does not include** the 3-410-101 – Rotary Encoder

Procedure

1. Use a medium flat blade screwdriver and a small protective piece of rubber (as a fulcrum) to remove the Rotary Knob.
2. Position the rubber piece next to the Knob, and slide in the screwdriver between the Knob and the Case.
3. Gentle lever the Knob up and off of its mounting shaft.
4. Position the replacement Knob over the shaft and press into place. There is no required orientation of the Knob.

6-16 Opening the Instrument Case

This procedure provides instructions for opening the MS202xC VNA Master case. With the case opened, the internal assemblies can be removed and replaced, as described in the sections that follow opening the case.

Procedure

1. As shown in [Figure 6-12](#), place the VNA Master MS202xC face down on a clean, stable work surface that will not scratch the front panel.
2. Remove the battery door and battery. Refer to [Section 5-4 “Battery Pack Removal and Replacement”](#) on page 5-3.
3. Use a Phillips screwdriver to remove the four (4) Pan Head Phillips-head screws securing the two Case halves together.

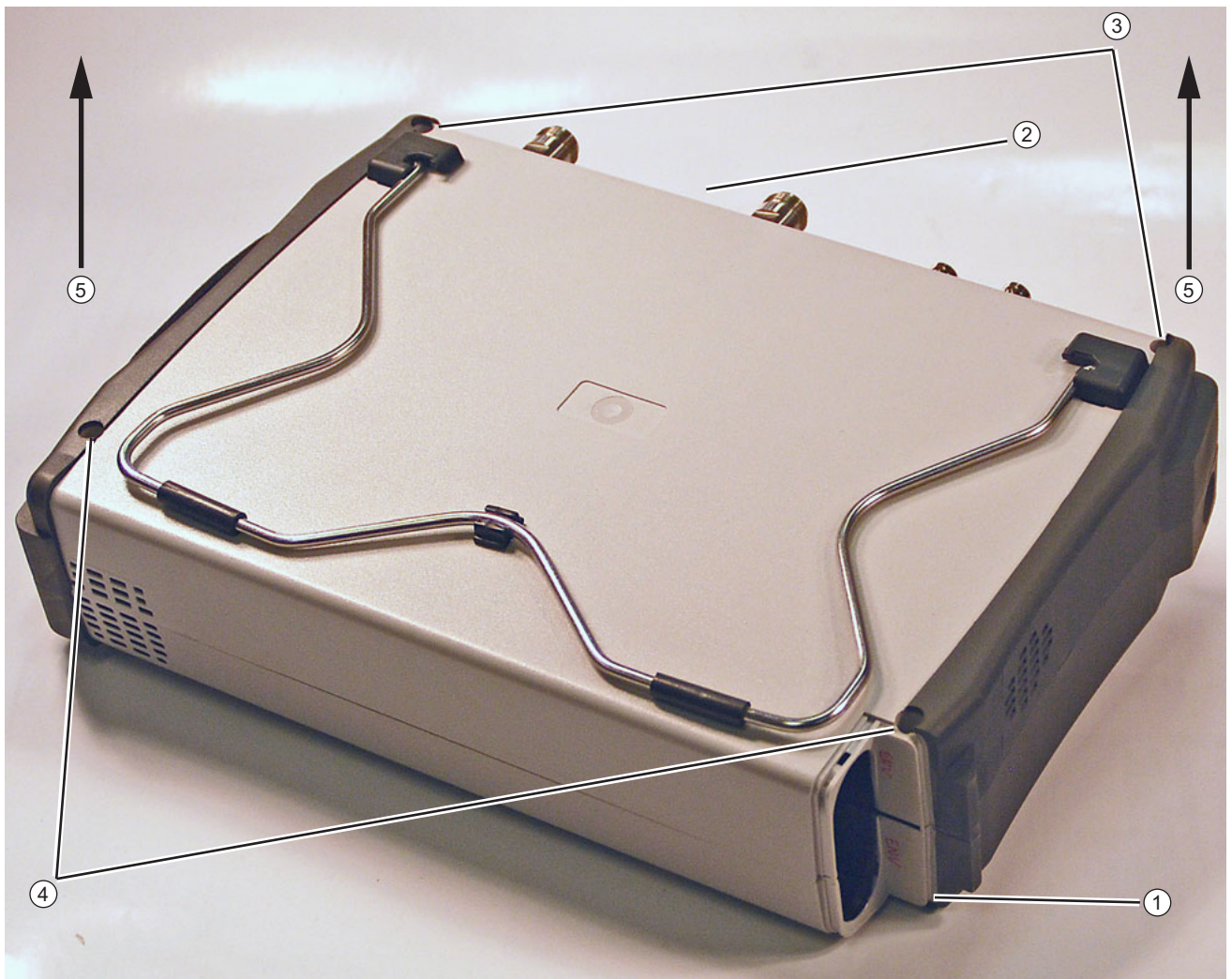

1. Remove Battery Cover and Battery
2. Orient case with connector panel as shown
3. Remove two (2) Phillips-head screws at top
4. Remove two (2) Phillips-head screws at bottom
5. At both ends of the Case Rear, lift up both ends evenly. The top connector panel stays with the Case Front Assembly.

Figure 6-12. Opening the Case

- Carefully lift up on the sides of the case and begin to separate the two halves.

The top connector panel stays with the front half of the case.

- The two halves of the instrument can now be safely separated. Set the **Case Rear Assembly** aside. The **Case Front Assembly** contains all of the serviceable parts.

- Refer to the following sections to remove and replace specific components of the instrument:

- [Section 6-11 “Replacing Main Keypad Components – 3-61362, 3-71027-3” on page 6-12](#)
- [Section 6-12 “Replacing Main Menu Keypad Rubber Membrane – 3-61361” on page 6-15](#)
- [Section 6-13 “Replacing Main Menu Keypad Components” on page 6-17](#)
- [Section 6-14 “Replacing Hand Strap – 3-61470” on page 6-21](#)
- [Section 6-15 “Replacing Rotary Knob – 3-61360-2” on page 6-22](#)
- [Section 6-16 “Opening the Instrument Case” on page 6-23 \(this procedure\)](#)
- [Section 6-17 “Replacing Power Monitor PCB Assembly, Option 5 – ND67197” on page 6-25](#)
- [Section 6-18 “Replacing VNA PCB Assembly” on page 6-28](#)
- [Section 6-19 “Replacing GPS Receiver Module \(Option 31\) – ND70320” on page 6-35](#)
- [Section 6-20 “Replacing Rotary Encoder – 3-410-101” on page 6-39](#)
- [Section 6-21 “Removing Main PCB Assembly” on page 6-42](#)
- [Section 6-22 “Replacing Main PCB Assembly – ND72084, ND72085” on page 6-45](#)
- [Section 6-23 “Replacing LCD Display – 3-15-154” on page 6-48](#)
- [Section 6-24 “Replacing Clear Plastic LCD Protector – 3-61368” on page 6-49](#)
- [Section 6-25 “Installing Main PCB and Reassembling Instrument” on page 6-50](#)
- [Section 6-26 “Replacing Fan Assembly – ND70948” on page 6-55](#)

Caution	Proper routing of the cables is important for instrument performance and for being able to reassemble the case halves.
----------------	--

Closing the Case

- With the **Case Front Assembly** face down on a clean, stable work surface that will not scratch the front panel, place the **Case Rear Assembly** over the front and align all parts.
- Carefully close the case, guiding the top connector panel into case grooves.
- Use a Phillips screwdriver to replace the four (4) Pan Head Phillips-head screws securing the two Case halves together. Torque these screws to 7.5 lbf·in (0.85 N·m).
- Replace the battery and battery door. Refer to [Section 5-4 “Battery Pack Removal and Replacement” on page 5-3](#).

Installing Battery:

Refer to [Section 5-4 “Battery Pack Removal and Replacement” on page 5-3](#).

- Install the Battery.
- Install the Battery Door.

Restarting the Instrument:

- Restart the instrument.
- Perform a function check to verify all repairs and part replacements.

6-17 Replacing Power Monitor PCB Assembly, Option 5 – ND67197

This procedure provides instructions for replacing the Power Monitor PCB Assembly (Option 5) and its related Detector connector.

Part Number

- ND67197 – Power Monitor PCB Assembly, includes the BNC connector on Flex Board and mounting hardware.

Procedure

1. Open the case as described in [Section 6-16 “Opening the Instrument Case”](#) on page 6-23.
2. Locate the Power Monitor Assembly PCB Option as shown in [Figure 6-13](#).

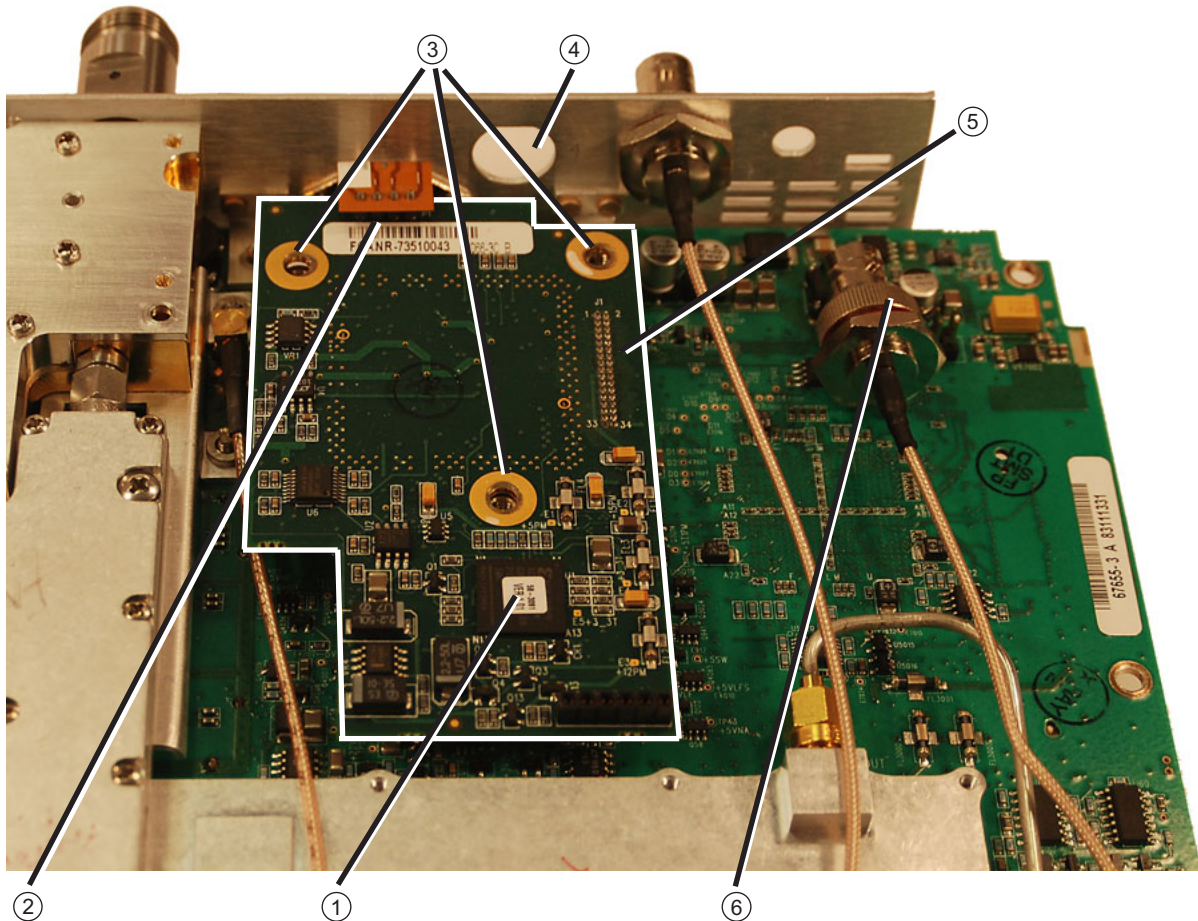

1. Optional Power Monitor PCB Assembly - Option 5
2. Removable Flex Cable 4-Pin connector between Detector connector (on connector panel) and Power Monitor PCB.
3. Mounting screws (3 each) (removed in this image)
4. Mounting hole on connector panel for removed Ext. Trig BNC connector.
5. Location of Header and M-M Header Pin Strip under PCB between Power Monitor PCB and VNA Assembly PCB
6. Ext. Trig. BNC connector that must be removed to access a VNA PCB Assembly mounting screw (not shown).

Figure 6-13. Power Monitor PCB Assembly - Option 5

6-17 Replacing Power Monitor PCB Assembly, Option 5 – ND67197 Assembly Removal and Replacement,

Disconnecting Detector Connector Flex Cable:

3. Pry out the Connector Flex Cable that is attached to the Detector connector from the Power Monitor PCB.
4. Remove the three (3) Phillips-head screws from the Power Monitor PCB.
5. Holding the Connector Flex PCB Cable away from the Power Monitor PCB, gently lever up the PCB out of its header socket.

Checking Header Pins:

6. If the M-M Header Pins stay on the VNA PCB Assembly, then remove the pins and reinstall them on the Power Monitor PCB.

Removing Power Monitor Detector Connector

7. To remove the Power Monitor Detector connector from the top connector panel, use a 5.5 mm angled-head open-end wrench to undo the two M3 x 0.5 Kep Nuts with lock washers.
8. When the nuts are removed, pull the Power Monitor Detector connector towards the VNA PCB Assembly until it clears the top connector panel, and then set it aside with the Power Monitor PCB.

Installing Replacement Power Monitor PCB:

9. Install the replacement Power Monitor Detector connector into the top connector panel. Note that the Flex Cable must oriented above the Connector. Reinstall and tighten the two M3 x 0.5 Kep Nuts (tighten firmly—no torque specification).
10. Holding the Flex Cable up, reinstall the Power Monitor PCB.

Caution	Use extreme care to avoid bending any of the header pins as they mate with the header strip on the VNA PCB Assembly. Be careful to not offset the header pins by one row.
----------------	---

11. Press on each side of the header strip to mate the two connectors.
12. Inspect the Header connectors from the side to make sure that all pins are correctly inserted and that no pins are bent.
13. Reinstall and tighten the three (3) Phillips-head screws holding the Power Monitor PCB to the VNA PCB Assembly. Torque these screws to 7.5 lbf ·in (0.85 N ·m).

Connecting Detector Flex Cable:

14. Insert the 4-pin header on the end of the Detector Connector Flex Cable into the Power Monitor PCB.
15. Make sure that all cables are clear from the Case assemblies.
16. Replace the case rear assembly and the battery

Caution	All cables along the lower edge of the Mother Board and VNA PCB Assembly must be routed in such a manner that they will not be pinched between, or protrude between, the case halves of the upper battery compartment. If any cable protrudes into the battery compartment when the case is closed, then the cable may be damaged by pinching, or If any cable protrudes into the battery compartment when the case is closed, then the cable may be damaged by pinching, or by the battery when it is inserted, or it may prevent battery insertion.
----------------	---

Replacing Case Rear Assembly and Battery

1. Replace the Case Bottom Assembly, making sure that the top connector panel is correctly centered in its mounting groove in the case back. Insert and tighten the four case mounting screws.
Torque these screws to 7.5 lbf ·in (0.85 N ·m).

Installing Battery:

Refer to [Section 5-4 “Battery Pack Removal and Replacement”](#) on page 5-3.

2. Install the Battery.
3. Install the Battery Door.

Restarting the Instrument:

4. Restart the instrument.
5. Perform a function check to verify all repairs and part replacements.

6-18 Replacing VNA PCB Assembly

ND72088, ND72089, ND72090

This replacement procedure provides instructions for replacing the VNA PCB Assemblies for all variants of the MS202xC VNA Masters. In general, the VNA PCB Assembly is removed as a complete unit and then exchanged for a replacement part.

Part Numbers

- ND72088 – VNA PCB Assembly with N(f) connectors for MS2026C
For MS2026C instruments equipped with standard N(f) Test Ports
- ND72089 – VNA PCB Assembly with N(f) connectors for MS2028C
For MS2028C instruments equipped with standard N(f) Test Ports
- ND72090 – VNA PCB Assembly with K(f) connectors for MS2028C
For MS2028C instruments equipped with Option 11 K(f) Test Ports

Removal Procedure

Opening the Case:

1. Open the case as described in [Section 6-16 “Opening the Instrument Case” on page 6-23](#).

Removing Power Monitor PCB, Option 5:

2. If the Power Monitor PCB (Option 5) is NOT installed, then skip ahead to [Step 3](#). If the Power Monitor PCB is installed, then perform the following sub steps.
 - a. Refer to [Figure 6-13 on page 6-25](#) for Power Monitor PCB connectors and orientation. Pry out the flex cable that is attached to the Detector connector from the Power Monitor PCB.
 - b. Remove the three Phillips-head screws from the Power Monitor PCB.
 - c. Using the Tool T1451 socket, remove the BNC Connector Dress Nut from the Ext Trig Input connector. Leave the Ext Trig Input connector and its attached coaxial cable loosely in place in the top connector panel.
 - d. Holding the Ext Trig Input connector flex cable away from the Power Monitor PCB, gently lever up the PCB out of its header socket.
 - e. If the Header Pins stay on the VNA PCB Assembly, then remove the pins and reinstall them on the Power Monitor PCB.
 - f. Set aside the Power Monitor PCB assembly with header pins.
 - g. Removing the Power Monitor PCB provides access to the Ext Trig Input BNC connector and a VNA PCB Assembly mounting screw. Refer to [Step 5](#).

Disconnecting GPS Antenna Cable:

3. If the GPS Receiver Module PCB (Option 31) is NOT installed, then skip ahead to [Step 4](#). If the GPS Receiver Module PCB is installed, then perform the following sub steps:
 - a. Use two 5/16 inch (\cong 8 mm) wrenches to disconnect the GPS Antenna SMA connector from the top connector panel.
 - b. Remove the nut and lock washer and then remove the SMA connector from the top connector panel.

Note	Replacing the nut and lock washer on the SMA connector after removal keeps all related parts conveniently located.
-------------	--

- c. Route the cable to the side, clearing the notch and the top connector panel, so it is clear of the VNA PCB Assembly.

Removing Cables and Ext Trig Input BNC:

Three or four cables connect the VNA PCB Assembly to the Main PCB Assembly (Mother Board or MB). One cable, from the VNA Module, is connected directly to the VNA PCB. The other cables are from connectors on the top connector panel.

- Ext Ref Input connector to MB J2200
- VNA Module to MB J2201
- Ext Trig Input connector to MB J2202
- GPS Antenna connector (if installed) to GPS PCB on MB

Continue Replacing the VNA PCB Assembly:

4. Cut the cable tie (if used) that holds the Ext Trig Input and Ext Ref Input coaxial cables to the RF Out semi-rigid coaxial cable.
5. Using the Tool T1451 socket, remove the BNC Connector Dress Nut from the Ext Trig Input connector. Pull the Ext Trig Input connector from the top connector panel and position it out of the way.

Removing the Ext Trig Input connector provides access to a VNA PCB Assembly mounting screw.

Identifying VNA PCB Assembly Mounting Screws:

6. Using [Figure 6-14](#), identify the locations of the eight (8) Phillips-head mounting screws that hold the VNA Assembly PCB in place.

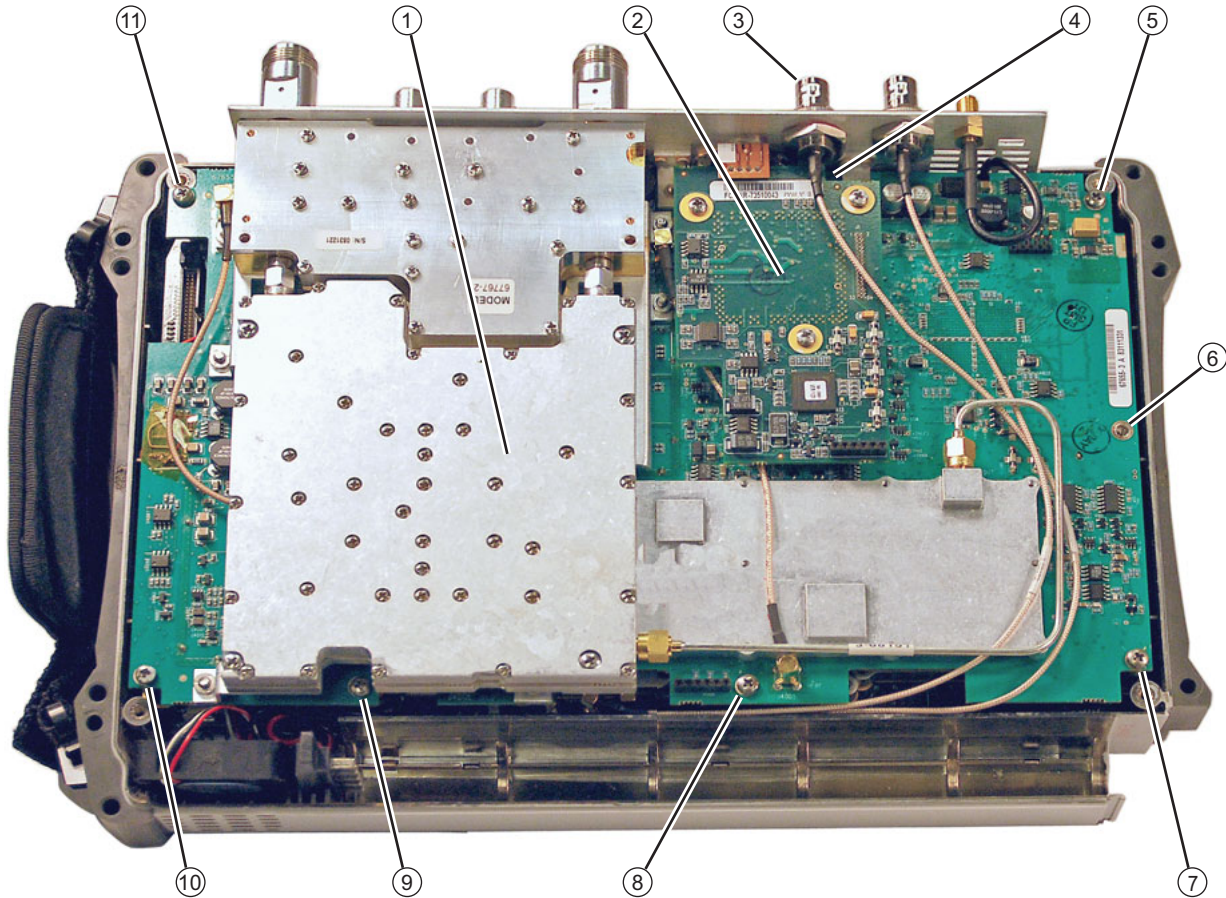

1. VNA PCB Assembly and related RF Shields with eight (8) total mounting screws
2. Location of Power Monitor Assembly PCB Option 5 with three (3) Phillips-head mounting screws
3. Remove the castellated nut and loosen the Ext Trig Input BNC Connector before removing Power Monitor PCB
4. The first VNA PCB Assembly Phillips-head mounting screw under Power Monitor PCB
5. 6, 7, 8, 9, 10, and 11. Additional Phillips-head mounting screws (7 total) holding VNA PCB Assembly in place

Note that cables in this figure may not match newer VNA Master MS202xC instruments. Refer to [Figure 6-15 on page 6-31](#).

Figure 6-14. VNA PCB Assembly Screw Locations

Removing the VNA PCB Assembly:

7. Using a Phillips-head screwdriver, remove the eight (8) screws holding the VNA PCB Assembly in place.

Note These eight screws attach the VNA PCB Assembly to 8 standoffs, which secure the Main PCB Assembly (MB) to the front case.

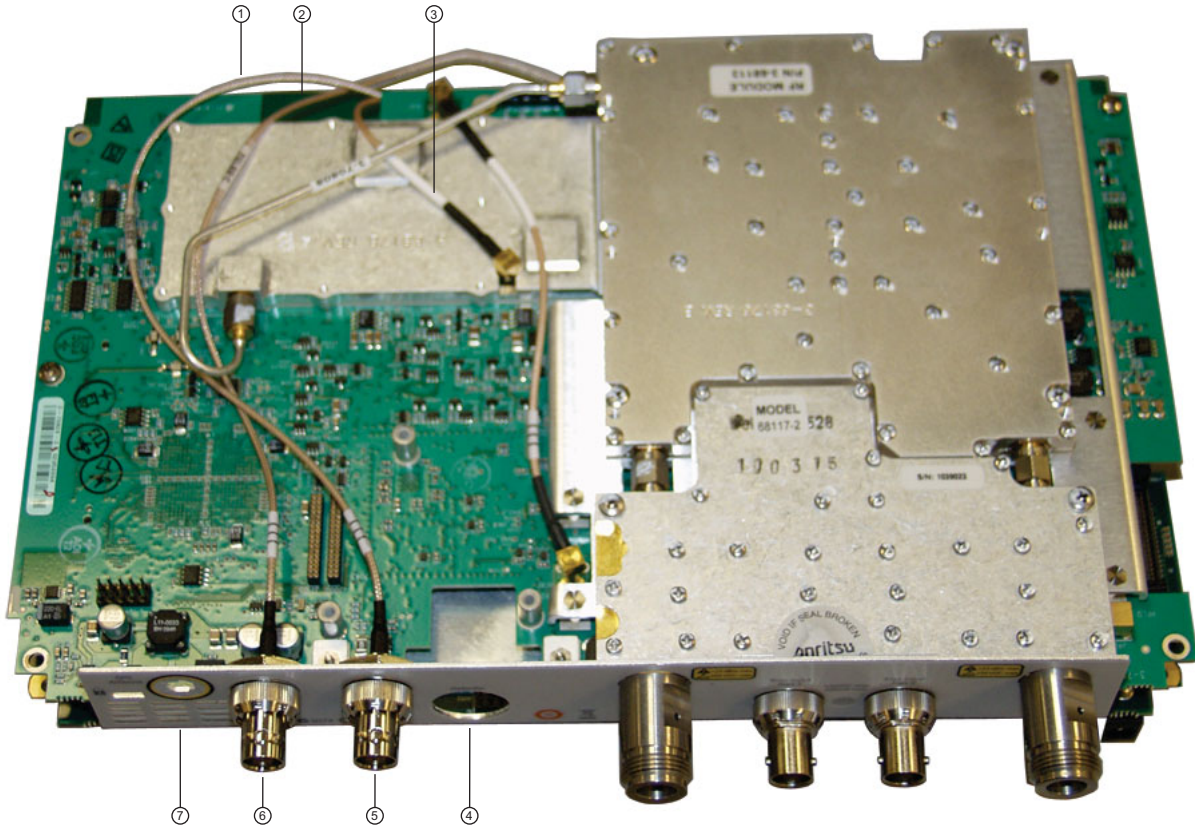

1. Cable, Ext Trig Input, to MB J3202
2. Cable, Ext Ref Input, to MB J2200
3. Cable, VNA Reference, 26 MHz, to MB J2201
4. Location of Power Monitor Connector (Option 5) or hole plug (Power Monitor option not installed)
5. External Trigger Input Connector
6. External Reference Input Connector
7. Location of GPS Antenna Connector (Option 31) or hole plug

Figure 6-15. Cables Connecting Main PCB (Mother Board) and VNA PCB (MS2028C shown)

8. Gently lift the top connector plate clear of the case front and raise the VNA PCB Assembly just enough to slide it toward the top of the case in order to expose the connectors along the lower edge of the Main PCB Assembly (Mother Board).

9. Use needle-nose pliers to remove the following 3 cable connections from the Main PCB Assembly, leaving the cables attached to the VNA Assembly (refer to [Figure 6-15](#) and [Figure 6-16](#)):
 - a. Ext Ref Input cable (from connector panel) at J2200, 100 MHz, MMCX connector (Item 10 in [Figure 6-16](#))
 - b. VNA Module cable (from connector in top shield) at J2201, 26 MHz Out, MCX connector (Item 9 in [Figure 6-16](#))
 - c. Ext Trig Input cable (from connector panel) at J3202, Trig In, MMCX connector (Item 8 in [Figure 6-16](#))

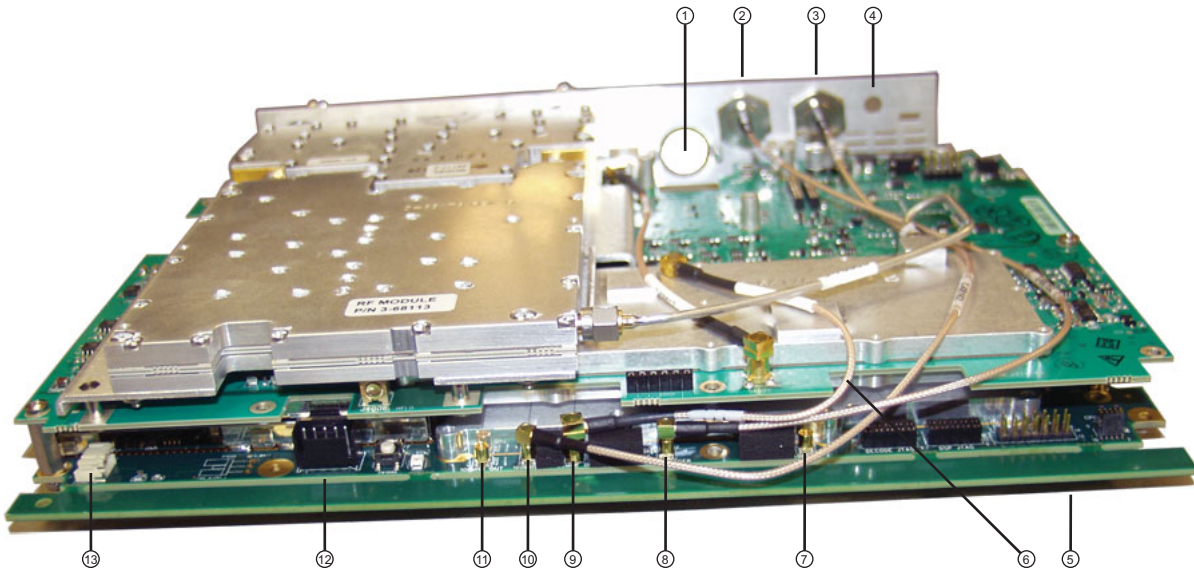

1. Connector Panel opening for Power Monitor (Option 5) RF Detector Interface
2. External Trigger Input connector
3. External Reference Input connector
4. Capped opening for GPS (Option 31) Antenna Connector
5. General location of connector J4202 on Mother Board (for LCD signal cable)
6. Cable for VNA reference, 26 MHz Out (from Mother Board connector J2201)
7. MB J3203, MMCX connector for 140 MHz IF (not used in MS202xC models)
8. MB J3202, MMCX connector for External Trigger (for Item 3)
9. MB J2201, MCX connector for 26 MHz Out to VNA module (cable is Item 6)
10. MB J2200, MMCX connector for External Reference Input (for Item 3)
11. MB J2202, MMCX connector for 100 MHz Out (not used in MS202xC models)
12. MB J1003, Battery connector
13. MB J1002, Fan connector

Figure 6-16. Cables Connecting Main PCB (Mother Board) and VNA PCB (MS2028C shown)

10. Remove the VNA PCB Assembly with cables attached, and set it aside.

Preparing the Replacement VNA PCB Assembly:

Exchange cables from the removed VNA PCB Assembly to the new VNA PCB Assembly. Note that the castellated BNC dress nut torque specification is 7.5 lbf · in (0.85 N · m).

11. Remove the castellated BNC dress nut from the Ext Ref Input BNC connector from the top connector panel. Install the BNC connector and its coaxial cable on the top connector panel of the new VNA PCB Assembly.
12. Remove the castellated BNC dress nut from the Ext Trig Input BNC connector from the top connector panel. Install the BNC connector and its coaxial cable on the top connector panel of the new VNA PCB Assembly.

13. Remove the 26 MHz cable from the VNA Module. Attach one end of the cable to the MCX connector on the top shield of the VNA Module of the new VNA PCB Assembly. Refer to item 6 in [Figure 6-16 on page 6-32](#).
14. If equipped with the **GPS Receiver Module (Option 31)**, then remove the hole plug for the GPS Antenna from the top connector panel. Refer to item 7 in [Figure 6-15 on page 6-31](#).
15. If equipped with the **Power Monitor (Option 5)**, then remove the hole plug for the Detector from the top connector panel prior to installing the PCB as described in the following steps. Refer to item 4 in [Figure 6-15 on page 6-31](#).

Installing the Replacement VNA PCB Assembly:

16. If the GPS Receiver Module PCB (Option 31) is installed, then ensure that its antenna cable is out of the way.
17. Position the replacement VNA PCB Assembly above the top case and above the Mother Board with the lower edge of the Mother Board and the connectors exposed.
18. Attach the cable from the MCX Connector (J7002) in the top shield of the replacement VNA PCB Assembly to MCX Connector J2201 on the Mother Board. Refer to item 6 and item 9 in [Figure 6-16 on page 6-32](#).
19. Route the cable from the Ext Ref Input connector through the notch to the Main PCB and attach it to the J2200 Ext Ref In MMXC connector.
20. Route the cable from the Ext Trig Input connector through the notch to the Main PCB and attach it to the J3202 Trig In MMXC connector.

Installing the GPS Antenna SMA Connector (Option 31):

If the GPS Receiver Module PCB (Option 31) is not installed, then skip ahead to [Step 21](#). If the GPS Receiver Module PCB is installed, then perform the following sub steps:

- a. Route the GPS Antenna Cable (with its SMA connector from the Main PCB) through the notch between the top connector panel and the PCB, and into its position in the top connector panel.
 - b. Install the lock washer and then the nut.
 - c. Use two 5/16 inch (~8 mm) wrenches to attach the GPS Antenna SMA connector to the top connector panel. Torque the nut to 7.5 lbf·in (0.85 N·m).
21. Carefully position the VNA PCB Assembly over the Main PCB and the eight (8) hex standoffs.
 22. Fasten the VNA PCB Assembly into place using eight (8) Phillips-head screws. Torque these screws to 7.5 lbf·in (0.85 N·m).

Installing the Power Monitor PCB, Option 5:

23. If the Power Monitor PCB (Option 5) is not installed, then skip ahead to [Step 24](#). If the Power Monitor PCB is installed, then perform the following sub steps:
 - a. Insert the Detector connector with the Flex Cable into the Detector hole on the top connector panel.
 - b. The Flex Cable must oriented above the Connector. Reinstall and tighten the two M3 x 0.5 Kep Nuts using the 5.5mm angled-head open end wrench. Tighten firmly. These nuts have no torque specification.
 - c. Carefully position the Power Module Assembly over its mounting standoffs.
 - d. Use extreme care so as to not bend any of the header pins.
 - e. Be careful to not offset the header pins by one row.
 - f. Make sure that the pins are loosely but correctly positioned before proceeding.
 - g. When perfectly aligned, press on each side of the header strip to mate the two connectors.
 - h. When the Power Monitor PCB is fully seated, inspect Header connectors from the side to Make sure that all pins are correctly inserted and no pins are bent.

- i. Install the three (3) Phillips-head screws holding the Power Monitor PCB in place. Torque these screws to 7.5 lbf ·in (0.85 N ·m).
- j. Gently fold over the Flex Cable and insert it into the four connector socket on the PCB.

Installing the Ext Trig BNC Connector and Dress Cables:

24. Reinstall the Ext Trig Input BNC connector in the top connector panel. Use the Tool T1451 socket to tighten the BNC Connector Dress Nut. The torque specification is 7.5 lbf ·in (0.85 N ·m).
25. Make sure that all cables are clear of the case edges.
26. Install a cable tie over the two coax cables and the RF semi-rigid to keep them in place.

Replacing Case Rear Assembly:

27. Replace the Case Bottom Assembly, making sure that the top connector panel is correctly centered in its mounting groove in the case back and that all cables are clear. Insert and tighten the four case mounting screws. Torque these screws to 7.5 lbf ·in (0.85 N ·m).

Caution

All cables along the lower edge of the Mother Board and VNA PCB Assembly must be routed in such a manner that they will not be pinched between, or protrude between, the case halves of the upper battery compartment. If any cable protrudes into the battery compartment when the case is closed, then the cable may be damaged by pinching, or by the battery when it is inserted, or it may prevent battery insertion.

Installing Battery:

Refer to [Section 5-4 “Battery Pack Removal and Replacement”](#) on page 5-3.

28. Install the Battery.
29. Install the Battery Door.

Restarting the Instrument:

30. Restart the instrument.
31. Perform a function check to verify all repairs and part replacements.

6-19 Replacing GPS Receiver Module (Option 31) – ND70320

This replacement procedure provides instructions for replacing the GPS Receiver Module mounted on the Main PCB Assembly for all variants of the MS202xC vector network analyzers. The basic procedure is to open the case, remove the VNA PCB Assembly, and then service the GPS Module.

Part Numbers

- ND70320 – GPS Receiver Module, Option 31
 - For MS202xC instruments equipped with Option 31 GPS Receiver
 - Includes SMA connector and cable to Receiver Module
 - Does not include GPS Antenna 2000-1528-R

Procedure

Opening the Case:

1. Open the case as described in [Section 6-16 “Opening the Instrument Case”](#) on page 6-23.

Removing Power Monitor PCB Option 5:

2. If the Power Monitor PCB (Option 5) is NOT installed, then skip ahead to [Step 3](#). If the Power Monitor PCB is installed, then perform the following sub steps:
 - a. Refer to [Figure 6-13 on page 6-25](#) for Power Monitor PCB connectors and orientation. Pry out the flex cable that is attached to the Detector connector from the Power Monitor PCB.
 - b. Remove the three Phillips-head screws from the Power Monitor PCB.
 - c. Using the Tool T1451 socket, remove the BNC Connector Dress Nut from the Ext Trig Input connector. Leave the Ext Trig Input connector and its attached coaxial cable loosely in place in the top connector panel.
 - d. Holding the Connector Flex Cable away from the Power Monitor PCB, gently lever up the PCB out of its header socket.
 - e. If the Header Pins stay on the VNA PCB Assembly, then remove the pins and reinstall them on the Power Monitor PCB.
 - f. Set the Power Monitor PCB assembly with header pins aside.
 - g. Removing the Power Monitor PCB provides access to the Ext Trig Input BNC connector and a VNA PCB Assembly mounting screw.

Disconnecting GPS Antenna Cable:

3. Disconnect the GPS Antenna SMA connector from the top connector panel by performing the following sub steps:
 - a. Use two 5/16 inch (\cong 8 mm) end wrenches to disconnect the GPS Antenna SMA connector from the top connector panel.
 - b. Pull off the nut and lock washer and remove the SMA connector from the top Connector panel.

Note	Replacing the nut and lock washer on the SMA connector after removal keeps all related parts conveniently located.
-------------	--

- c. Route the cable to the right side, clearing its notch and the top connector panel, so that it is clear of the VNA PCB Assembly and the Case Front Assembly.

Removing Ext Trig Input BNC Connector:

4. Cut the cable tie (if used) that holds the Ext Trig Input and Ext Ref Input coaxial cable to the RF Out semi-rigid.

5. Using the Tool T1451 socket, remove the BNC Connector Dress Nut from the Ext Trig Input connector. Pull the Ext Trig Input connector from the top connector panel and position so it is out of the way. Removing the Ext Trig Input connector provides access to on the VNA PCB Assembly mounting screws.
6. Using a Phillips-head screwdriver, remove the eight (8) screws holding the VNA PCB Assembly in place.

Partially Removing the VNA PCB Assembly:

7. Gently lift the VNA PCB Assembly without disconnecting any cables and without applying excessive stress to the cables. Carefully fold back the VNA PCB Assembly as if opening a book, and lay it edge to edge with the Main PCB Assembly (Mother Board).

Disconnecting and Removing the GPS Antenna Cable:

8. Use needle-nose pliers to remove the MCX RF coaxial connector from the GPS Receiver Module.
9. Undo the two screws holding the GPS Receiver Module in place.
10. Gently pull the GPS Receiver Module straight up to disconnect its 14-pin header connector. The header pins should stay with the GPS Module.

Preparing and Installing the Replacement GPS Receiver Module:

11. Remove the replacement GPS Module from its packing material and prepare it for installation.
12. Orient the replacement GPS Receiver Module so that it is lined up with its mounting holes and 14-pin header connector. Observe the following:
 - a. Carefully position the GPB Receiver Module PCB over its mounting standoffs.
 - b. Use extreme care so as to not bend any of the header pins.
 - c. Be careful to not offset the header pins by one row.
 - d. Make sure that the header pins are loosely but correctly positioned before proceeding.
 - e. When the header pins are perfectly aligned, press on each side of the header strip to mate the two connectors.
13. Insert and tighten the two Phillips mounting screws. Torque these screws to 7.5 lbf ·in (0.85 N ·m).

Note that these screws are shorter than the screws that are used to hold the VNA Assembly in place.

Installing the GPS Antenna Cable and SMA Connector:

14. Snap the GPS Antenna Cable MCX connector into place on the GPS Receiver Module. Position the Antenna Cable off the right side of the Case.
15. “Fold” the VNA PCB Assembly back into position over the Main PCB and align it with the eight (8) hex standoffs so that it is loosely positioned.
16. Route the GPS Antenna Cable with SMA connector in the slot between the top connector panel and the PCB, until the cable is correctly positioned in the PCB notch cutout.
17. Install the SMA connector into the top connector panel, add the lock washer and the nut.
18. Use two 5/16 inch (\cong 8 mm) wrenches to tighten the GPS Antenna SMA connector to the top connector panel. Torque the nut to 7.5 lbf ·in (0.85 N ·m).

Installing the VNA PCB Assembly:

19. Position the VNA PCB Assembly as accurately as possible over the Main PCB Assembly observing the following:
 - The fan and other cables on the side of the Case are clear of the hex standoffs and the Case edge.
 - The GPS Antenna Cable is correctly routed between the top connector panel and the PCB and is located in its notch.
 - The coaxial cables between the two PCBs are on the OUTSIDE of the hex standoffs and also clear of the Case edge.

- Carefully align these cables to be parallel with the edge of the PCB.

Caution

All cables along the lower edge of the Mother Board and VNA PCB Assembly must be routed in such a manner that they will not be pinched between, or protrude between, the case halves of the upper battery compartment. If any cable protrudes into the battery compartment when the case is closed, then the cable may be damaged by pinching, or by the battery when it is inserted, or it may prevent battery insertion.

20. Make sure that the VNA PCB Assembly is correctly positioned over the standoffs on the Mother Board, and then fasten it into place using eight (8) Phillips-head screws.
Torque these screws to 7.5 lbf ·in (0.85 N ·m).

Installing the Power Monitor PCB:

21. If the Power Monitor PCB (Option 5) is not installed, then skip ahead to [Step 22](#). If the Power Monitor PCB is installed, then perform the following sub steps:
- a. Insert the Detector connector with the Flex Cable into the Detector hole on the top Connector panel.
 - b. The Flex Cable must be oriented above the Connector. Reinstall and tighten the two M3 x 0.5 Kep Nuts using the 5.5 mm angled-head open end wrench or a nut driver. These nuts have no torque specification. Tighten firmly.
 - c. Carefully position the Power Module Assembly over its mounting standoffs.
 - d. Use extreme care so as to not bend any of the header pins.
 - e. Be careful to not offset the header pins by one row.
 - f. Make sure that the pins are loosely but correctly positioned before proceeding.
 - g. When perfectly aligned, press on each side of the header strip to mate the two connectors.
 - h. When the Power Monitor PCB is fully seated, inspect the header connectors from the side to make sure that all pins are correctly inserted and no pins are bent.
 - i. Install the three (3) Phillips-head screws holding the Power Monitor PCB in place. Torque these screws to 7.5 lbf ·in (0.85 N ·m).
 - j. Gently fold over the Flex Cable and insert it into the four-connector socket on the PCB. Refer to [Figure 6-13 on page 6-25](#) for Power Monitor PCB and Connector orientation. Refer to [Figure 6-16 on page 6-32](#) for coaxial cable connections between the VNA PCB Assembly and the Main PCB Assembly.

Installing the Ext. Trig. Input BNC Connector:

22. Reinstall the Ext Trig Input BNC connector and its coaxial cable into the top connector panel. Route the coaxial cable under the RF semi-rigid and use the Tool T1451 socket to tighten the BNC Connector Dress Nut to 7.5 lbf ·in (0.85 N ·m).
23. Make sure that all cables are clear of the case edges.
24. Install a cable tie over the two coaxial cables and the RF semi-rigid to keep them in place.

Installing Case Bottom Assembly and Battery:

25. Replace the Case Bottom Assembly, making sure that the top connector panel is correctly centered in its mounting groove in the case back and that all cables are clear. Insert and tighten the four case mounting screws. Torque these screws to 7.5 lbf · in (0.85 N · m).

Caution

All cables along the lower edge of the Mother Board and VNA PCB Assembly must be routed in such a manner that they will not be pinched between, or protrude between, the case halves of the upper battery compartment. If any cable protrudes into the battery compartment when the case is closed, then the cable may be damaged by pinching, or by the battery when it is inserted, or it may prevent battery insertion.

Installing Battery:

Refer to [Section 5-4 “Battery Pack Removal and Replacement”](#) on page 5-3.

26. Install the Battery.
27. Install the Battery Door.

Restarting the Instrument:

28. Restart the instrument.
29. Perform a function check to verify all repairs and part replacements.

6-20 Replacing Rotary Encoder – 3-410-101

Replacing the Rotary Encoder involves removing the Rotary Knob, and then opening the case and partially removing the VNA PCB Assembly. If the Power Monitor PCB (Option 5) is installed, then this PCB must be removed. If the GPS Receiver Module (Option 5) is installed, then the GPS Antenna must be disconnected. After the VNA PCB Assembly is “folded” out of the way, the Rotary Encoder mounting hardware can be loosened from the Front Panel, and its cable can be detached from the Main PCB Assembly. The Main PCB Assembly need not be removed to replace the Rotary Encoder.

Part Numbers

- 3-410-101 – Rotary Encoder
 - For either MS2026C or MS2028C instruments
 - Includes the connection cable to the Main PCB Assembly, connector J5010.
 - Does not include the Rotary Knob – 3-61360-2

Procedure

Removing the Rotary Knob:

1. Use a flat-blade screwdriver and piece of rubber (as a fulcrum) to remove the Rotary Knob.
2. Use a 7/16 inch (\cong 12 mm) nut driver to remove the nut, lock washer, and flat washer that hold the Encoder in place.
3. Open the case as described in [Section 6-16 “Opening the Instrument Case” on page 6-23](#).

Removing Power Monitor PCB (Option 5):

4. If the Power Monitor PCB (Option 5) is NOT installed, then skip ahead to [Step 5](#). If the Power Monitor PCB is installed, then perform the following sub steps:
 - a. Refer to [Figure 6-13 on page 6-25](#) for Power Monitor PCB connectors and orientation. Pry out the flex cable attached to the Detector connector from the Power Monitor PCB.
 - b. Remove the three Phillips-head screws from the Power Monitor PCB.
 - c. Using the Tool T1451 socket, remove the BNC Connector Dress Nut from the Ext Trig Input connector. Leave the Ext Trig Input connector and its attached coaxial cable loosely in place in the top connector panel.
 - d. Holding the Connector Flex Cable away from the Power Monitor PCB, gently lever up the PCB out of its header socket.
 - e. If the Header Pins stay on the VNA PCB Assembly, then remove the pins and reinstall them on the Power Monitor PCB.
 - f. Set the Power Monitor PCB assembly with header pins aside.
 - g. Removing the Power Monitor PCB provides access to the Ext Trig Input BNC connector and a VNA PCB Assembly mounting screw.

Removing the Ext Trig Input BNC Connector:

5. Cut the cable tie (if used) that holds the Ext Trig Input and Ext Ref Input coaxial cable to the RF Out semi-rigid.
6. Using the Anritsu Tool T1451, the castellated socket, remove the BNC Connector Dress Nut from the Ext Trig Input connector. Pull the Ext Trig Input connector from the top connector panel and position it out of the way.

Removing the Ext Trig Input connector provides access to a VNA PCB Assembly mounting screw.

Removing the VNA PCB Assembly:

7. Using a Phillips-head screwdriver, remove the eight (8) screws holding the VNA PCB Assembly in place.

8. Gently lift the VNA PCB Assembly without disconnecting any cables and without applying excessive stress to the cables. Carefully fold back the VNA PCB Assembly as if opening a book, and lay it edge to edge with the Main PCB Assembly (Mother Board).

Removing the GPS Receiver Module (Option 5):

9. If the GPS Receiver Module PCB (Option 31) is not installed, then skip ahead to [Step 10](#). If it is installed, then perform the following sub steps:
 - a. Use needle-nose pliers to remove the MCX RF coaxial connector from the GPS Receiver Module.
 - b. Leave the GPS Antenna SMA connector attached to the top connector panel.

Removing the Rotary Encoder:

10. On the inside of the case, disconnect the Rotary Encoder cable from the Main PCB Assembly.
11. Remove the old Rotary Encoder and its attached cable from the case and set it aside.

Installing Replacement Rotary Encoder:

12. Position the **replacement Rotary Encoder** in the case with the cable connector towards the center of the Case.
13. Attach the Rotary Encoder cable to the Main PCB Assembly connector J5010. The cable connector goes into the PCB connector on the side away from the Encoder with the connector ridges up. Coil up excess cable on top of the encoder PCB.
14. From the front panel, add—in sequence—the flat washer, lock washer, and nut. Tighten the nut to hold in place by using the 7/16 inch (\cong 12 mm) nut driver. Torque the nut to 8 lbf · in (0.9 N · m).
15. From the front panel, press on the Rotary Knob.

Installing GPS Receiver Module (Option 5):

16. If the GPS Receiver Monitor PCB (Option 31) is not installed, then skip ahead to [Step 17](#). If it is installed, then perform the following sub steps:
 - a. Route the GPS Antenna Cable MCX connector into place to the GPS Receiver Module.
 - b. Use needle-nose pliers to attach the MCX connector to the GPS Receiver Module.

Installing the VNA PCB Assembly:

17. “Fold” the VNA PCB Assembly back into position over the Main PCB and the eight (8) hex standoffs, positioning it as accurately as possible over the Main PCB Assembly, observing the following:
 - The fan and other cables on the side of the Case are clear of the hex standoffs and the Case edge.
 - The GPS Antenna Cable is correctly routed between the top connector panel and the PCB and is located in its notch.
 - The coaxial cables between the two PCBs are on the OUTSIDE of the hex standoffs and also clear of the Case edge.
 - Carefully align these cables parallel with the edge of the PCB.

Caution

All cables along the lower edge of the Mother Board and VNA PCB Assembly must be routed in such a manner that they will not be pinched between, or protrude between, the case halves of the upper battery compartment. If any cable protrudes into the battery compartment when the case is closed, then the cable may be damaged by pinching, or by the battery when it is inserted, or it may prevent battery insertion.

18. Make sure that the VNA PCB Assembly is correctly positioned over the standoffs on the Mother Board, and then fasten it into place using eight (8) Phillips-head screws. Torque these screws to 7.5 lbf · in (0.85 N · m).

Installing Power Monitor PCB (Option 5):

19. If the Power Monitor PCB (Option 5) is not installed, then skip ahead to [Step 20](#). If it is installed, then perform the following sub steps:
- Insert the Detector connector with the Flex Cable into the Detector hole on the top connector panel.
 - The Flex Cable must be oriented above the Connector. Reinstall and tighten the two M3 x 0.5 Kep Nuts using the 5.5 mm angled-head open end wrench or a nut driver. These nuts have no torque specification. Tighten firmly.
 - Carefully position the Power Monitor Assembly over its mounting standoffs.
 - Use extreme care so as to not bend any of the header pins.
Be careful to not offset the header pins by one row.
Make sure that the pins are loosely but correctly positioned before proceeding.
 - When perfectly aligned, press on each side of the header strip to mate the two connectors.
 - When the Power Monitor PCB is fully seated, inspect the header connectors from the side to make sure that all pins are correctly inserted and that no pins are bent.
 - Install the three (3) Phillips-head screws holding the Power Monitor PCB in place. Torque these screws to 7.5 lbf · in (0.85 N · m).
 - Gently fold over the Flex Cable and insert it into the four-connector socket on the PCB. Refer to [Figure 6-13 on page 6-25](#) for Power Monitor PCB and Connector orientation. Refer to [Figure 6-16 on page 6-32](#) for coaxial cable connections between the VNA PCB Assembly and the Main PCB Assembly.

Installing the Ext Trig Input BNC:

- Install the External Trigger Input BNC connector and coaxial cable into the top connector panel.
- Route the coaxial cable UNDER the RF semi-rigid and use the Tool T1451 socket to tighten the BNC Connector Dress Nut to a torque of 7.5 lbf · in (0.85 N · m).
- Make sure that all cables are clear of the case edges.
- Install a cable tie over the two coaxial cables and the RF semi-rigid to keep them in place.

Installing the Case Bottom Assembly and Battery:

- Replace the Case Bottom Assembly, making sure that the top connector panel is correctly centered in its mounting groove in the case back and that all cables are clear. Insert and tighten the four case mounting screws. Torque these screws to 7.5 lbf · in (0.85 N · m).

Caution	All cables along the lower edge of the Mother Board and VNA PCB Assembly must be routed in such a manner that they will not be pinched between, or protrude between, the case halves of the upper battery compartment. If any cable protrudes into the battery compartment when the case is closed, then the cable may be damaged by pinching, or by the battery when it is inserted, or it may prevent battery insertion.
----------------	--

Installing Battery:

Refer to [Section 5-4 “Battery Pack Removal and Replacement” on page 5-3](#).

- Install the Battery.
- Install the Battery Door.

Restarting the Instrument:

- Restart the instrument.
- Perform a function check to verify all repairs and part replacements.

6-21 Removing Main PCB Assembly

This procedure covers removing the Main PCB Assembly (Mother Board) from the MS2026C and MS2028C instruments by removing the Power Monitor PCB Assembly (if installed), the VNA PCB Assembly, the GPS Receiver Module (if installed), and then the Main PCB Assembly. After the Main PCB Assembly is removed, separate replacement procedures are available:

- [Section 6-22 “Replacing Main PCB Assembly – ND72084, ND72085” on page 6-45](#)
- [Section 6-23 “Replacing LCD Display – 3-15-154” on page 6-48](#)
- [Section 6-24 “Replacing Clear Plastic LCD Protector – 3-61368” on page 6-49](#)

After the required replacement units are installed, the final procedure describes how to reinstall the Main PCB Assembly, GPS Receiver Module, VNA PCB Assembly, Power Monitor PCB, and then close the case:

- [Section 6-25 “Installing Main PCB and Reassembling Instrument” on page 6-50](#)

Procedure

1. Place the instrument face up on a protected work surface oriented with the Connector Strip away from you.
2. Remove the Battery Door and the Battery.
3. Carefully turn the instrument face down.
4. Open the case by removing the four (4) fastening screws. Lift up the Case Rear Assembly and set it aside.

Removing Power Monitor PCB (Option 5):

5. If the Power Monitor PCB (Option 5) is NOT installed, then skip ahead to [Step 6](#). If the Power Monitor PCB is installed, then perform the following sub steps:
 - a. Refer to [Figure 6-13 on page 6-25](#) for Power Monitor PCB connectors and orientation. Pry out the flex cable that is attached to the Detector connector from the Power Monitor PCB.
 - b. Remove the three Phillips-head screws from the Power Monitor PCB.
 - c. Using the Tool T1451 socket, remove the BNC Connector Dress Nut from the Ext Trig Input connector. Leave the Ext Trig Input connector and its attached coaxial cable loosely in place in the top connector panel.

Removing the Ext Trig Input connector provides access to one of the VNA PCB Assembly mounting screws.
 - d. Holding the Connector Flex Cable away from the Power Monitor PCB, gently lever up the PCB out of its header socket.
 - e. If the Header Pins stay on the VNA PCB Assembly, then remove the pins and reinstall them on the Power Monitor PCB.
 - f. Set aside the Power Monitor PCB assembly with header pins.
 - g. Removing the Power Monitor PCB provides access to the Ext Trig Input BNC connector and to a VNA PCB Assembly mounting screw.

Removing Ext Trig Input BNC Connector:

6. Cut the cable tie (if used) that holds the Ext Trig Input and Ext Ref Input coaxial cables to the RF Out semi-rigid.
7. Using the Tool T1451 socket, remove the BNC Connector Dress Nut from the Ext Trig Input connector. Pull the Ext Trig Input connector from the Connector Face Plate and position it out of the way.
 - Removing the Ext Trig Input connector provides access to one of the VNA Module PCB mounting screws.

Removing VNA PCB Assembly:

8. Using a Phillips-head screwdriver, remove the eight (8) screws holding the VNA PCB Assembly in place.

9. Gently lift the VNA PCB Assembly without disconnecting any cables and without applying excessive stress to the cables. Carefully fold back the VNA PCB Assembly as if opening a book, and lay it edge to edge with the Main PCB Assembly (Mother Board).

Removing GPS Receiver Module PCB Option 31:

10. If the GPS Receiver Module PCB Option 31 is not installed, then skip ahead to [Step 11](#). If it is installed, then perform the following sub steps:
 - a. Use needle-nose pliers to remove the MCX RF coaxial connector from the GPS Receiver Module PCB.
 - b. Undo the two screws holding the GPS Receiver Module in place.
 - c. Gently pull the GPS Receiver Module straight up to disconnect its 14-pin header connector.

Removing Coaxial Cables:

11. Using needle-nose pliers, remove the three attached coaxial cables from the Main PCB Assembly at the following locations. All three cables route to locations on the VNA PCB Assembly. Leave the cables attached to the VNA PCB Assembly.
 - J2200 100 MHz In – Cable connected to the Ext Ref In BNC connector on the VNA PCB Assembly.
 - J2201 26 MHz Out – Cable connected to the RF shield on top of the VNA Module.
 - J3202 Trig In – Cable connected to the Ext Trig In BNC connector on the VNA PCB Assembly.

Refer to [Figure 6-14 on page 6-30](#) and [Figure 6-15 on page 6-31](#) for coaxial cable connections between the VNA PCB Assembly and the Main PCB Assembly.

Note	On the Main PCB Assembly, the MCX connectors for J2202 100 MHz Out and J3203 140 MHz IF are not used.
-------------	---

Removing Main PCB Assembly:

12. Remove seven (7) of the eight (8) hex standoffs and the two (2) Pan Head screws holding the Main PCB Assembly to the Case Front Assembly. Refer to [Figure 6-17](#) for hex standoff and screw locations. Item 2 in [Figure 6-17](#) is the standoff that remains.

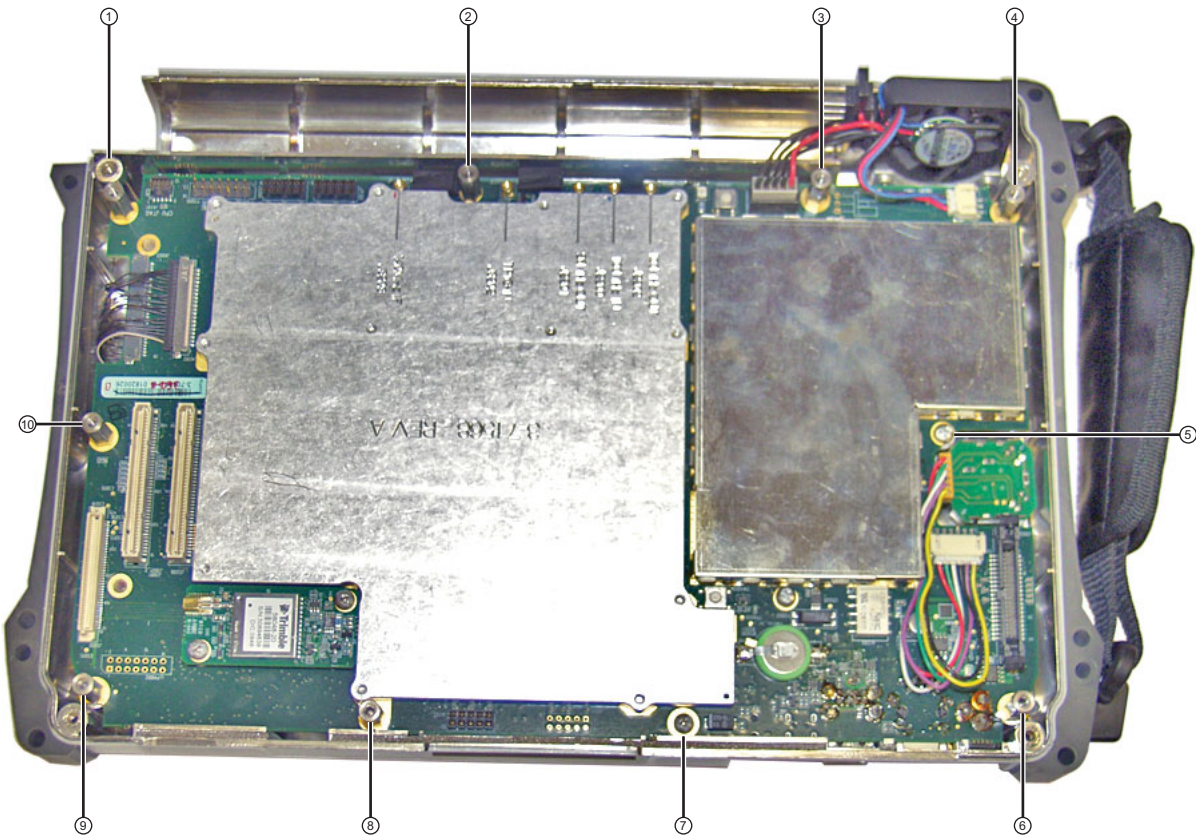

8 Hexagonal Standoffs, items: 1, 2, 3, 4, 6, 8, 9, 10. Remove items 1, 3, 4, 6, 8, 9, and 10.

Do not remove standoff, item 2.

2 Pan Head Screws, items: 5 and 7, remove both

Figure 6-17. Screws and Standoffs that Secure the Mother Board to the Case Front

13. Near the handle side of the case, disconnect the cable from the Rotary Encoder PCB. The Rotary Encoder stays mounted in the Case Front Assembly.
14. Near the bottom of the case, disconnect the Battery Cable and the Fan Cable from the Main PCB and fold them over the case edge clear of the PCB.
15. Holding the standoff (item 2 in [Figure 6-17](#)), apply a slight pressure to the Mother Board toward the top of the case by pressing on a shield. The connectors (External Power Input, LAN, USB, and Headset Jack) protrude into the Case Front. Lift on the standoff to pivot the Main PCB against the top of the case until the connector to the Main Keypad Assembly is disconnected.
16. Carefully lift the entire Main PCB from the case by drawing the Lan and USB connectors away from the case top. Then set the Main PCB aside.
17. At this point, proceed with any of the following replacement procedures:
 - [Section 6-22 “Replacing Main PCB Assembly – ND72084, ND72085” on page 6-45](#)
 - [Section 6-23 “Replacing LCD Display – 3-15-154” on page 6-48](#)
 - [Section 6-24 “Replacing Clear Plastic LCD Protector – 3-61368” on page 6-49](#)
18. After the required replacement procedures are complete, reassemble the instrument using the procedure in [Section 6-25 “Installing Main PCB and Reassembling Instrument” on page 6-50](#).

6-22 Replacing Main PCB Assembly – ND72084, ND72085

This procedure begins with the assumption that the Main PCB Assembly has been removed from the instrument as described in [Section 6-21 “Removing Main PCB Assembly” on page 6-42](#) and that the Main PCB Assembly is to be replaced. The basic replacement procedure is the same for MS2026C and MS2028C instruments.

If an assembly mounted on or under the Main PCB is to be replaced, then skip to the appropriate section:

- [Section 6-23 “Replacing LCD Display – 3-15-154” on page 6-48](#)
- [Section 6-24 “Replacing Clear Plastic LCD Protector – 3-61368” on page 6-49](#)

Part Numbers

- ND72084 – Main PCB Assembly for MS2026C instruments
 - VNA PCB Assembly not included
 - LCD Display not included
 - GPS Receiver Module PCB not included
- ND72085 – Main PCB Assembly for MS2028C instruments
 - VNA PCB Assembly not included
 - LCD Display not included
 - GPS Receiver Module PCB not included

Procedure

1. The Main PCB Assembly has been removed from the Case Front Assembly.

Preparing the Replacement Main PCB:

2. If the LCD Panel Assembly is to be replaced, then skip to [Section 6-23 “Replacing LCD Display – 3-15-154” on page 6-48](#). If the LCD Panel Assembly is not to be replaced, then continue here:

Removing the LCD Display:

3. Disconnect the LCD multi-pin cable (the LCD Signal cable) going to J4202 on the removed Main PCB Assembly (refer to [Figure 6-18](#)). The cable remains attached to the LCD Panel.
4. Disconnect the LCD Backlight cable going to P6000 on the removed Main PCB Assembly (refer to item 3 in [Figure 6-19](#)).
5. Undo the four (4) Phillips-head screws holding the LCD Display in place and set the LCD aside.

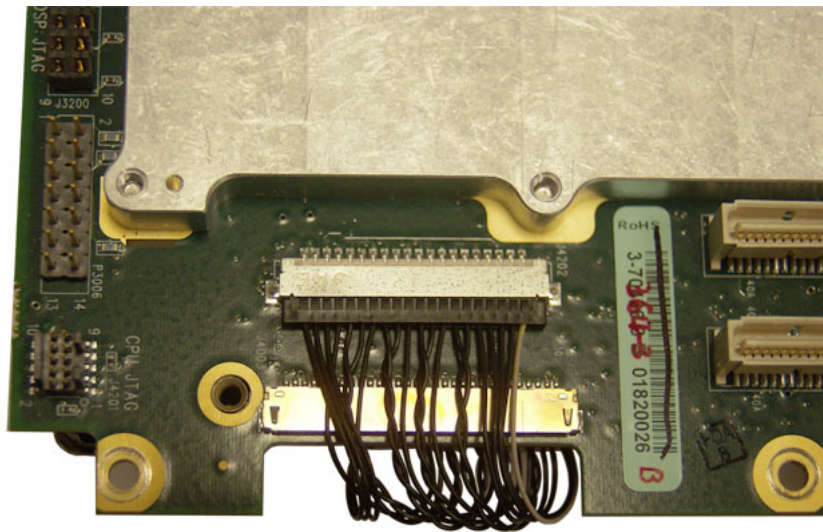
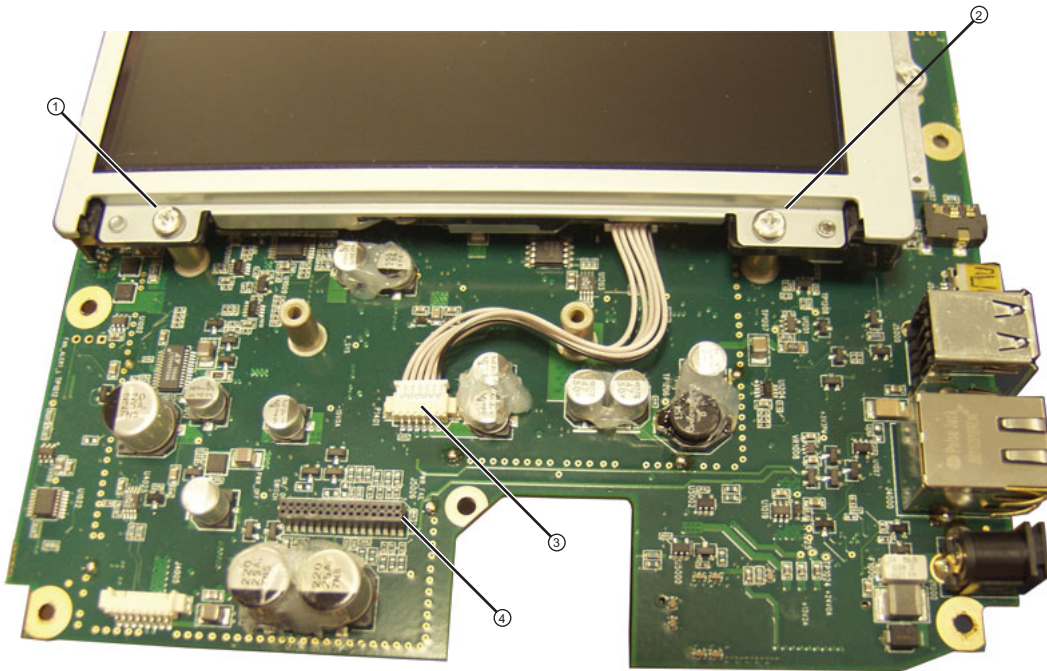

Figure 6-18. Connector J4202, for LCD Signal Cable to Mother Board



1. Phillips-head mounting screws (4 each) holding the LCD Assembly to the Main PCB Assembly (only 2 screws shown).
2. Phillips-head mounting screws (4 each) holding the LCD Assembly to the Main PCB Assembly (only 2 screws shown).
3. LCD Backlight Cable connection to P6000 connector on Main PCB Assembly.
4. Main PCB Assembly connector J5006 to Main Keyboard Assembly.

Figure 6-19. LCD Cable, Mounting Screws, and Backlight Cable

Removing the GPS Receiver Module:

6. If the GPS Receiver Module PCB (Option 31) is not installed, or if it has already been removed, then skip ahead to the next step. If it is installed and has not been removed, then perform the following sub steps:
 - a. Undo the two screws holding the GPS Receiver Module in place.
 - b. Gently pull the GPS Receiver Module straight up to disconnect its 14-pin header connector. The header connector should stay with the GPS Receiver Module.

Preparing the Replacement Main PCB:

7. Prepare the replacement Main PCB by installing the original LCD Display and, if equipped, the GPS Receiver Module, as described in the following steps.
8. Install the LCD Panel Assembly:
 - a. Fasten the LCD assembly in place with four (4) pan head screws. Torque these screws to 7.5 lbf · in (0.85 N · m).
 - b. Attach the LCD backlight cable to Mother Board connector P6000 (item 3 in [Figure 6-19](#)).
 - c. Attach the LCD Signal cable to the J4202 connector socket on the Main PCB (refer to [Figure 6-18](#)).
9. Before installing the reassembled Main PCB Assembly, clean the Clear Plastic LCD Protection Plate by using compressed air and LCD-compatible wipes.
10. The Main PCB Assembly is now ready to reassemble into the Case Front Assembly. Continue with the reassembly process in [Section 6-25 “Installing Main PCB and Reassembling Instrument”](#) on page 6-50.

6-23 Replacing LCD Display – 3-15-154

This procedure is written with the assumption that the Main PCB Assembly has been removed from the instrument as described previously, also that the Main PCB Assembly will not be replaced, but will be reinstalled, and that the LCD Display must be replaced. The replacement procedure is the same for MS2026C and MS2028C instruments.

Part Numbers

- 3-15-154 – LCD Display. For either MS2026C or MS2028C instruments

Procedure

1. Open the instrument case and remove the Main PCB Assembly and place it on a protected work surface with the LCD Panel facing up.

- Refer to [Section 6-21 “Removing Main PCB Assembly” on page 6-42](#).

Disconnecting the Two Cables Going to the LCD Display:

2. Disconnect the LCD multi-pin cable (the LCD Signal cable) going to J4202 on the Main PCB Assembly (refer to [Figure 6-18](#)). The cable remains attached to the LCD Panel.
3. Disconnect the LCD Backlight cable going to P6000 on the Main PCB Assembly (refer to item 3 in [Figure 6-19](#)). The cable remains attached to the LCD Panel.
4. Undo the four (4) Phillips pan head screws and remove the LCD Display Assembly.
5. Clean the replacement LCD Screen by using compressed air and LCD compatible wipes.
6. Install the replacement LCD Display Assembly by fastening it in place with four (4) Phillips-head screws. Torque these screws to 7.5 lbf · in (0.85 N · m).
7. Attach the LCD Backlight cable to P6000 on the Main PCB Assembly (refer to item 3 in [Figure 6-19](#)).

Note

Pay attention to the routing of the LCD Backlight and Signal Cables. The cables must be positioned so as not to be pinched when the assembly is reattached to the Case Front Assembly.

8. Connect the LCD multi-pin cable (the LCD Signal cable) to J4202 on the Main PCB Assembly (refer to [Figure 6-18](#)).
9. If no further replacements are pending, then install the Main PCB and reassemble the instrument by following the procedure in [Section 6-25 “Installing Main PCB and Reassembling Instrument” on page 6-50](#).

6-24 Replacing Clear Plastic LCD Protector – 3-61368

This procedure is written with the assumption that the Main PCB Assembly has been removed from the instrument as described previously, and that the Clear Plastic LCD Protector must be replaced. The replacement procedure is the same for MS2026C and MS2028C instruments.

Part Numbers

- 3-61368 – Clear Plastic LCD Protector. For either MS2026C or MS2028C instruments

Procedure

1. Open the instrument case and remove the Main PCB Assembly.
Refer to [Section 6-21 “Removing Main PCB Assembly” on page 6-42](#).
2. If the LCD Display is to be replaced, then remove the LCD Display as described in [Section 6-23 “Replacing LCD Display – 3-15-154” on page 6-48](#). If the LCD Display is NOT to be replaced, then skip to the next step.
3. Remove the Clear Plastic LCD Protector by pushing it from the front.
4. The protector has an inset edge which goes into the hole and faces out. The protector “lip” is set towards the inside of the case.
5. The outside of the Protector has a protective “skin” that should be left in place until the instrument is reassembled.
6. Clean the inside of the Protector by using compressed air and LCD compatible wipes.
7. Avoiding fingerprints, install the protector into the Case Front opening with the protector “lip” towards the inside of the case.
8. If no further unit replacements are required, then install the LCD Display (if required) and install the Main PCB and reassemble the instrument by using the following the procedures:
 - [Section 6-23 “Replacing LCD Display – 3-15-154” on page 6-48](#) (if required)
 - [Section 6-25 “Installing Main PCB and Reassembling Instrument” on page 6-50](#)
 - [Section 6-25 “Installing Main PCB and Reassembling Instrument” on page 6-50](#)

6-25 Installing Main PCB and Reassembling Instrument

This procedure is written with the assumption that the required assemblies have been replaced and installed on the Main PCB Assembly.

Procedure

Installing the Main PCB Components:

1. If not already done, then install the LCD Display PCB Assembly on the Main PCB with the following sub steps:
 - a. Install the LCD Display on the Main PCB with four (4) pan head screws oriented so that the multi-conductor signal cable matches up with its notch and connector J4202 on the Mother Board, and the LCD backlight cable is towards the connector P6000 on the Mother Board. Torque these screws to 7.5 lbf · in (0.85 N · m).
 - b. Connect the LCD Display cables. (Refer to [Step 7](#) and [Step 8 on page 6-48](#).)

Installing the Clear Plastic LCD Protector:

2. If not already done, then clean the inner surface of the Protector with compressed air and LCD compatible wipes, leaving the outer protective film in place, and place the Protector into the Case Front, with the “lip” towards the inside of the case.

Installing the Main PCB:

3. The connectors (External Power Input, LAN, USB, and Headset Jack) of the Main PCB will protrude into the Case Front. Holding the standoff (item 2 in [Figure 6-17](#)), insert that connector edge of the Main PCB first into the case.
 - a. Rest the edge of the Main PCB on the screw pads and apply a slight pressure to the Main PCB toward the top of the case by pressing on a shield. If the Main Keypad is not yet installed in the Case Front, then skip to [Step 4](#). If the Main Keypad is already installed in the Case Front, then continue with the following sub steps:

The purpose of the pressure is to ensure that the connectors are properly engaged into the case top. This helps to ensure alignment of the critical connection with the Main Keypad Assembly (J1 and J5006).
 - b. Lower the Main PCB while maintaining the slight upward pressure (via the shield) and by holding the standoff and pivoting the Main PCB against the top of the case until connector J1 of the Main Keypad Assembly is engaged in connector J5006 of the Main PCB (for J5006, refer to item 4 in [Figure 6-19 on page 6-46](#), and for J1, refer to item 1 in [Figure 6-20 on page 6-51](#)). Press down gently on the Main PCB shield to fully seat this connector.
 - c. Take care to ensure that you do not damage the connection between the Main PCB and the Main Keypad Assembly.

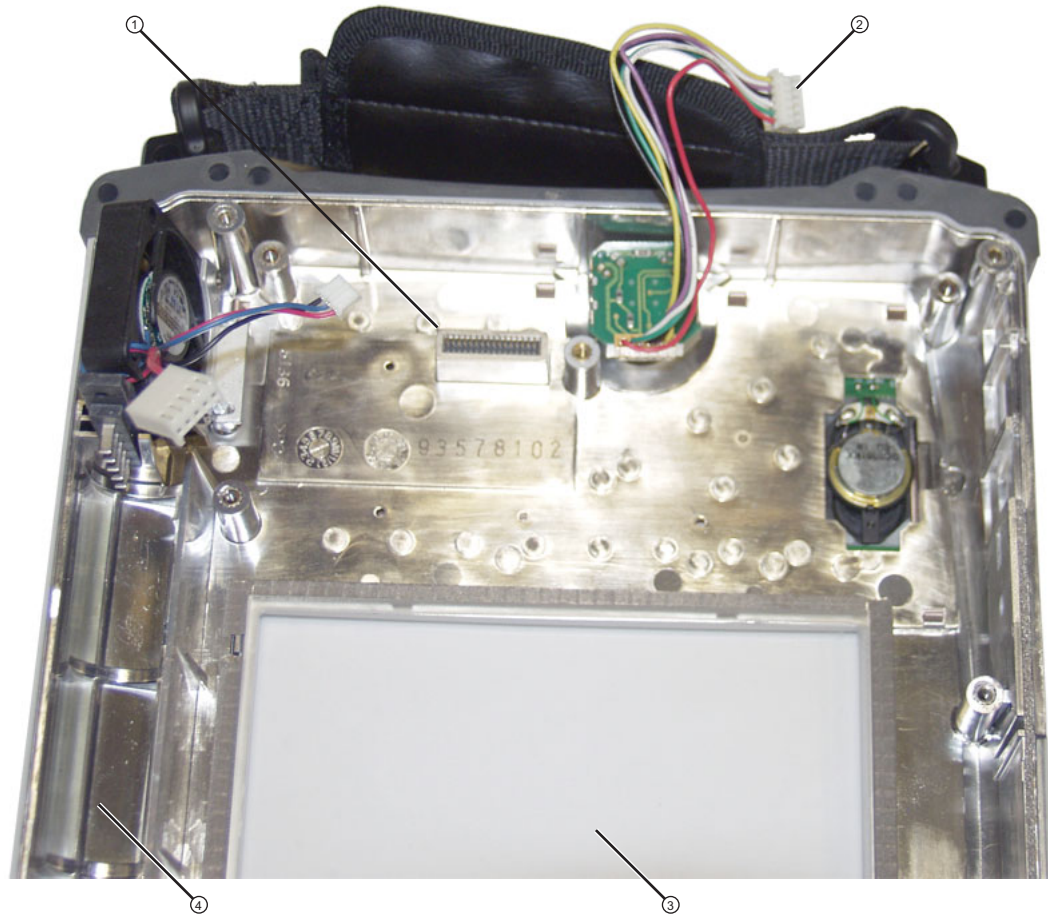

1. Connector J1 of Main Keypad Assembly (mates with J5006 on Mother Board)
2. Rotary Knob Connector (mates with J5010 on Mother Board)
3. Clear Plastic LCD Protector
4. Battery Compartment Section of Case Front

Figure 6-20. Front Case without Mother Board

4. Fasten the Main PCB into place with seven (7) hex standoffs and two (2) pan head screws. Torque these standoffs and screws to 7.5 lbf · in (0.85 N · m).
5. Connect the Battery Power cable to J1003 and the Fan cable to J1002 on the Main PCB (both cables are visible in [Figure 6-20](#), and the connectors are shown as item_12 and item_13 in [Figure 6-16 on page 6-32](#)).

Installing GPS Receiver Module:

6. If the GPS Receiver Module (Option 31) is not installed, then skip ahead to [Step 7](#). If it is installed, then perform the following sub steps:
 - a. Carefully position the replacement GPS Receiver Module so that it is lined up with its mounting standoff holes and 14-pin header connector on the Main PCB.
 - b. Use extreme care so as to not bend any of the header pins.
 - c. Be careful to not offset the header pins by one row.
 - d. Make sure that the header pins are loosely but correctly positioned before proceeding.
 - e. When perfectly aligned, press on each side of the header strip to mate the connectors and the header pins.

- f. Insert and tighten the two (2) Phillips-head mounting screws. Note that these screws are shorter than the screws that are used to hold the VNA PCB Assembly in place. Torque these screws to 7.5 lbf · in (0.85 N · m).
- g. Snap the GPS Antenna Cable MCX connector into place on the GPS Receiver Module. Position the Antenna Cable off the side of the Case. Do not yet install the GPS Antenna SMA connector in the top connector panel.

Installing VNA PCB Assembly:

If the VNA PCB Assembly is new, then refer to Section “[Preparing the Replacement VNA PCB Assembly:](#)” on [page 6-32](#). If the original VNA PCB Assembly is being replaced, then perform the following steps:

7. Place the VNA PCB Assembly upside down next to the Case and the Main PCB.

Refer to [Figure 6-14 on page 6-30](#), [Figure 6-15 on page 6-31](#), and [Figure 6-16 on page 6-32](#) for orientation photographs of general placement and cable routing.

8. Using needle-nose pliers, connect the three coaxial cables between the Main PCB and the VNA PCB Assembly:

- J2200 100 MHz In – Cable connected to the Ext Ref In BNC connector on the VNA PCB Assembly.
- J2201 26 MHz Out – Cable connected to the top RF shield on the VNA Module.
- J3202 Trig In – Cable connected to the Ext Trig In BNC connector on the VNA PCB Assembly.

Note	Note the routing for each cable. On the Main PCB Assembly (refer to Figure 6-16 on page 6-32), note that the MCX connectors for J2202 100 MHz Out (item_11) and J3203 140 MHz IF (item_7) are not used in MS20xC instruments.
-------------	--

Installing the VNA PCB Assembly:

9. If the GPS Receiver Module PCB (Option 31) is installed, then ensure that its antenna cable is out of the way.
10. Position the VNA PCB Assembly above the top case and the Mother Board with the lower edge of the Mother Board and the connectors exposed.
Refer to [Figure 6-14 on page 6-30](#), [Figure 6-15 on page 6-31](#), and [Figure 6-16 on page 6-32](#) for orientation photographs of general placement and cable routing.
11. Attach the cable from the MCX Connector in the top shield of the VNA Module to the J2201 MCX Connector on the Mother Board. Refer to item 6 (cable) and item 9 (J2202) in [Figure 6-16 on page 6-32](#).
12. Route the cable from the Ext Ref Input connector through the notch to the Main PCB and attach it to the J2200 Ext Ref In MMXC connector. Refer to item 10 in [Figure 6-16 on page 6-32](#).
13. Route the cable from the Ext Trig Input connector through the notch to the Main PCB and attach it to the J3202 Trig In MMXC connector. Refer to item 8 in [Figure 6-16 on page 6-32](#).
14. Gently move the VNA PCB Assembly over the Main PCB Assembly so that the connectors are engaged in the top connector panel.
15. If the GPS Receiver Module PCB (Option 31) is not installed, then skip ahead to [Step 16](#). If the GPS Receiver Module PCB is installed, then perform the following sub steps:
 - a. Route the GPS Antenna Cable (with its SMA connector from the Main PCB) through the notch between the top connector panel and the PCB, and into its position in the top connector panel.
 - b. Install the lock washer and then the nut, and tighten.
 - c. Use two 5/16 inch (~8 mm) wrenches to connect the GPS Antenna SMA connector to the top connector panel. Torque the nut to 7.5 lbf · in (0.85 N · m).
16. Carefully position the VNA PCB Assembly over the Main PCB and the eight (8) hex standoffs.
17. Fasten the VNA PCB Assembly into place using eight (8) Phillips-head screws. Torque these screws to 7.5 lbf · in (0.85 N · m).

Installing the Power Monitor PCB, Option 5:

18. If the Power Monitor PCB (Option 5) is not installed, then skip ahead to [Step 19](#). If the Power Monitor PCB is installed, then perform the following sub steps:
 - a. Insert the Detector connector with the Flex Cable into the Detector hole on the top connector panel.
 - b. The Flex Cable must oriented above the Connector. Reinstall and tighten the two M3 x 0.5 Kep Nuts using the 5.5mm angled-head open end wrench. Tighten firmly. These nuts have no torque specification.
 - c. Carefully position the Power Module Assembly over its mounting standoffs.
 - d. Use extreme care so as to not bend any of the header pins.
 - e. Be careful to not offset the header pins by one row.
 - f. Make sure that the pins are loosely but correctly positioned before proceeding.
 - g. When perfectly aligned, press on each side of the header strip to mate the two connectors.
 - h. When the Power Monitor PCB is fully seated, inspect Header connectors from the side to Make sure that all pins are correctly inserted and that no pins are bent.
 - i. Install the three (3) Phillips-head screws holding the Power Monitor PCB in place. Torque these screws to 7.5 lbf ·in (0.85 N ·m).
 - j. Gently fold over the Flex Cable and insert it into the four-connector socket on the PCB.

Installing the Ext Trig BNC Connector and Dress Cables:

19. Reinstall the Ext Trig Input BNC connector in the top connector panel. Use the Tool T1451 socket to tighten the BNC Connector Dress Nut. The torque specification is 7.5 lbf ·in (0.85 N ·m).
20. Make sure that all cables are clear of the case edges.
21. Install a cable tie over the two coax cables and the RF semi-rigid to keep them in place.

Replacing Case Rear Assembly:

22. Replace the Case Bottom Assembly, making sure that the top connector panel is correctly centered in its mounting groove in the case back and that all cables are clear. Insert and tighten the four case mounting screws. Torque these screws to 7.5 lbf ·in (0.85 N ·m).

Caution

All cables along the lower edge of the Mother Board and VNA PCB Assembly must be routed in such a manner that they will not be pinched between, or protrude between, the case halves of the upper battery compartment. If any cable protrudes into the battery compartment when the case is closed, then the cable may be damaged by pinching, or by the battery when it is inserted, or it may prevent battery insertion.

Installing Main and Main Menu Keypads:

If the Main Keypad was removed, then perform the following steps.

23. Install the Main Keypad PCB and the Main Menu Keypad Flex PCB into the front cover.
24. Carefully position the Main Keypad and insert the long header pin into the provided slot.
25. Gently press the Main Keypad into place so that the header pins mate with the connector on the Main PCB.
26. Fit the Main Keypad Bezel over the Main Keypad so that it is under the Speaker. Make sure that the Speaker is correctly positioned to fit into the pins.

Installing Battery:

Refer to [Section 5-4 “Battery Pack Removal and Replacement”](#) on page 5-3.

27. Install the Battery.
28. Install the Battery Door.

Restarting the Instrument:

29. Restart the instrument.
30. Perform a function check to verify all repairs and part replacements.

6-26 Replacing Fan Assembly – ND70948

This replacement procedure provides instructions for replacing the Fan Assembly for all variants of the MS202xC VNA Masters. In general, the case is opened and the Fan Assembly is replaced without disturbing any of the PCBs, and without disconnecting any RF cables. The entire Fan Assembly is then exchanged for a replacement part.

Part Numbers

- ND70948 – Fan Assembly for MS2026C and MS2028C instruments

Procedure

Summary:

- Open the case.
- If the Power Monitor option (Option 5) is installed, then remove the connector and PCB.
- If the GPS option (Option 32) is installed, then disconnect the GPS Antenna SMA connector.
- Unscrew and move the VNA PCB Assembly, but do not disconnect its cables.
- Remove and replace the Fan Assembly.
- Replace the VNA PCB Assembly.
- Replace the GPS Antenna SMA connector, if necessary.
- Replace the Power Monitor connector and PCB, if necessary.
- Close the Case.
- Replace the battery.
- Restart the instrument and perform a function check.

Opening the Case:

1. Open the case as described in [Section 6-16 “Opening the Instrument Case” on page 6-23](#).
Follow [Step 1](#) through [Step 5](#).

Removing Power Monitor PCB (Option 5):

2. If the Power Monitor PCB (Option 5) is NOT installed, then skip ahead to [Step 3](#). If the Power Monitor PCB is installed, then perform the following sub steps:
 - a. Refer to [Figure 6-22 on page 6-57](#) for Power Monitor PCB connectors and orientation. Pry out the flex cable that is attached to the Detector connector from the Power Monitor PCB.
 - b. Remove the three Phillips-head screws from the Power Monitor PCB.
 - c. Using the Tool T1451 socket, remove the BNC Connector Dress Nut from the Ext Trig Input connector. Leave the Ext Trig Input connector and its attached coaxial cable loosely in place in the top connector panel.

Removing the Ext Trig Input connector provides access to one of the VNA PCB Assembly mounting screws.
 - d. Holding the Connector Flex Cable away from the Power Monitor PCB, gently lever up the PCB out of its header socket.
 - e. If the Header Pins stay on the VNA PCB Assembly, then remove the pins and reinstall them on the Power Monitor PCB.
 - f. Set aside the Power Monitor PCB assembly with header pins.

Disconnecting GPS Antenna Cable:

3. If the GPS Receiver Module PCB (Option 31) is NOT installed, then skip ahead to [Step 4](#), noting the preliminary directions in section “[Moving VNA PCB Assembly](#).” If the GPS Receiver Module PCB is installed, then perform the following sub steps:
 - a. Use two 5/16 inch (\cong 8 mm) wrenches to disconnect the GPS Antenna SMA connector (item 3 in [Figure 6-21](#)) from the top connector panel.
 - b. Remove the nut and lock washer and then remove the SMA connector from the top connector panel.
 - c. Replace the lock washer and nut onto the SMA connector for safe keeping.
 - d. Route the cable to the side, clearing the notch and the top connector panel, so it is clear of the VNA PCB Assembly.
 - e. Removing the GPS Antenna SMA connector also provides easier access to one of the VNA PCB Assembly mounting screws.

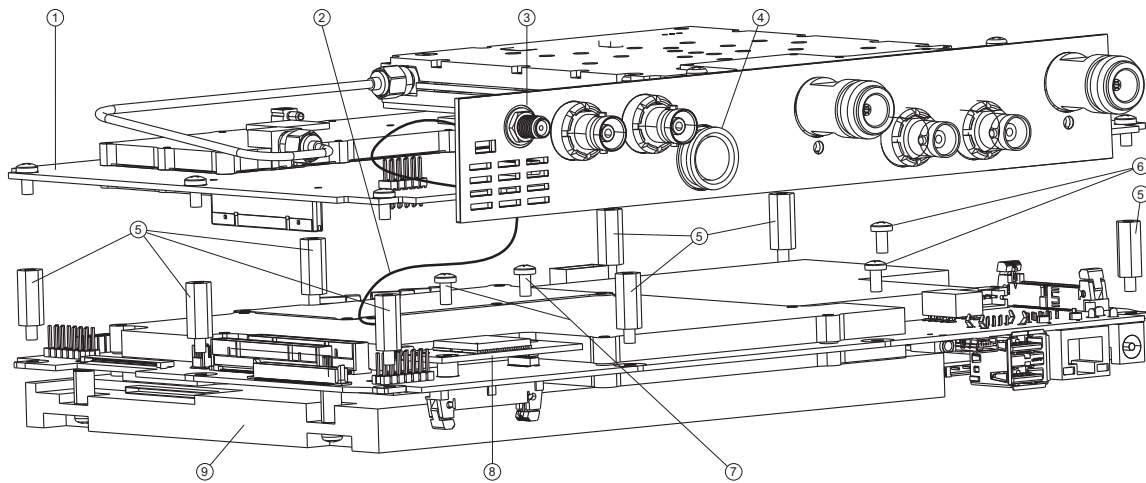

1. VNA PCB Assembly
2. GPS Antenna Cable
3. GPS Antenna SMA Connector
4. Power Monitor Detector Connector
5. Standoff (8 total) securing Mother Board to case and securing VNA PCB Assembly to Mother Board
6. Screws (2 total) securing Mother Board to case
7. Screws (2 total) securing GPS PCB to Mother Board
8. GPS PCB Assembly
9. Mother Board

Figure 6-21. Power Monitor, GPS, and VNA on Mother Board

Moving VNA PCB Assembly:

In this procedure, the VNA PCB Assembly is not removed completely, but is moved only far enough to expose the required Fan Assembly components.

Identifying VNA PCB Assembly Mounting Screws:

4. Using [Figure 6-22 on page 6-57](#), identify the locations of the eight (8) Phillips-head mounting screws that hold the VNA Assembly PCB in place. Note that these screws are secured to the 8 hexagonal standoffs that are shown as item 5 in [Figure 6-21](#).
5. Using a Phillips-head screwdriver, remove the eight (8) screws holding the VNA PCB Assembly in place.

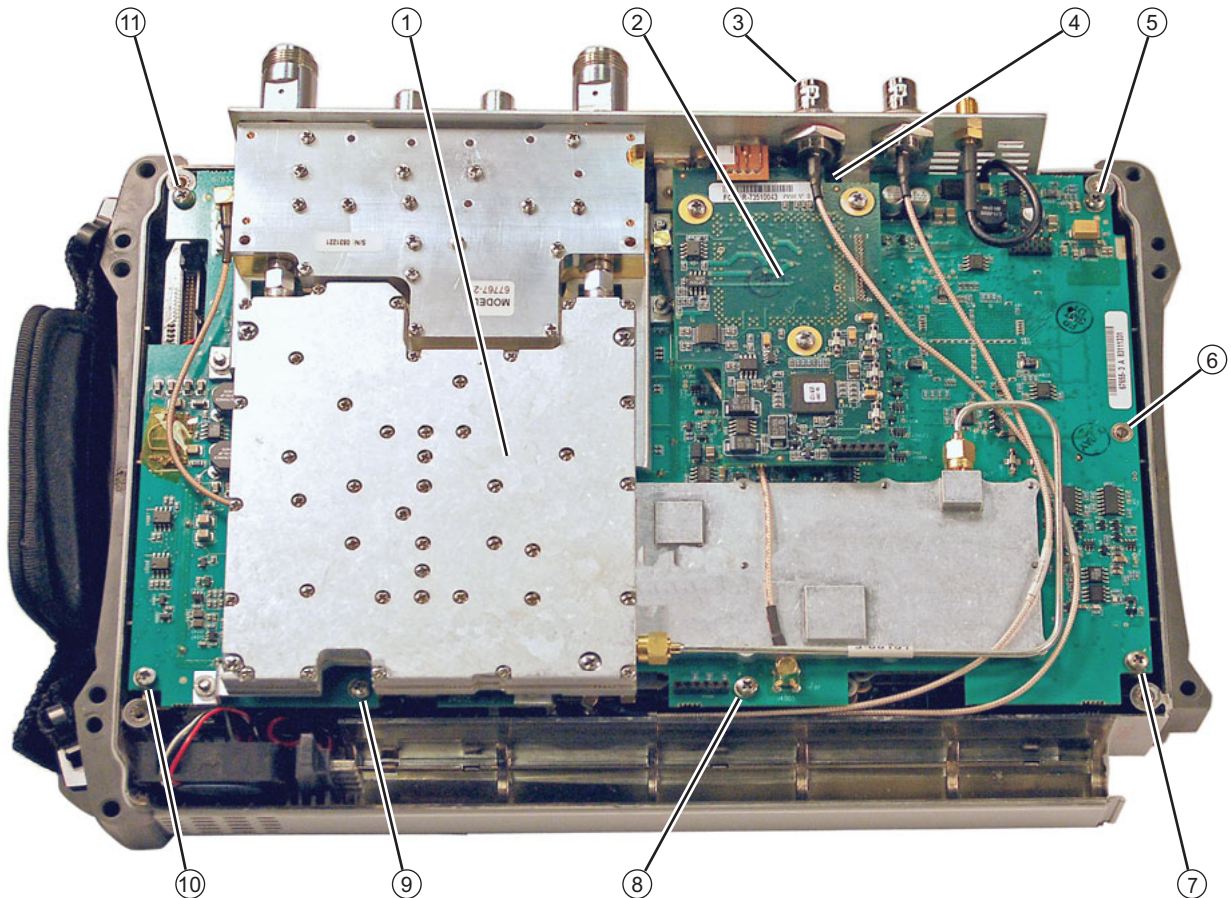

1. VNA PCB Assembly and related RF Shields with eight (8) total mounting screws
2. Location of Power Monitor Assembly PCB Option 5 with three (3) Phillips-head mounting screws
3. Remove the castellated nut and loosen the Ext Trig Input BNC Connector before removing Power Monitor PCB
4. The first VNA PCB Assembly Phillips-head mounting screw under Power Monitor PCB
5. Screws 5, 6, 7, 8, 9, 10, and 11. Additional Phillips-head mounting screws (7 total) holding VNA PCB Assembly in place

Note that cables in this figure may not match newer VNA Master MS202xC instruments. Refer to [Figure 6-15 on page 6-31](#).

Figure 6-22. VNA PCB Assembly Screw Locations

6. The VNA PCB Assembly is connected to the Mother Board and the SPA PCB with several cables. Some of the cables are shown in [Figure 6-24 on page 6-60](#). None of these cables are disconnected during Fan Assembly replacement. Observe all cables as the VNA PCB Assembly is moved and then replaced. Take care not to stress any of these cables.
7. Lift the top edge of the VNA Assembly (with the attached top connector panel) and carefully move the VNA Assembly up and in the direction of the top of the case in order to expose the cable connection for the Fan Assembly, connector J1002 on the Mother Board. Note that the VNA PCB Assembly and the SPA PCB Assembly cables are not shown in [Figure 6-23](#).
8. Gently pry the fan cable from Mother Board connector J1002. Refer to item 2 in [Figure 6-23](#).

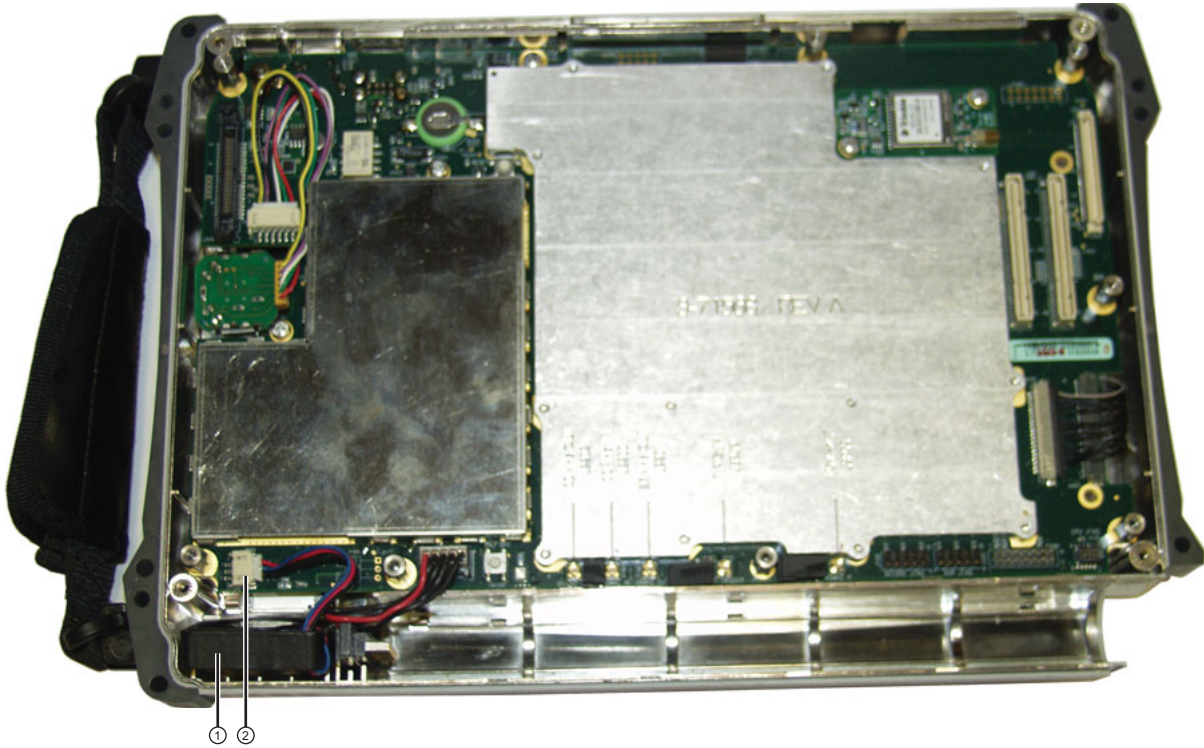

1. Fan
2. Fan Cable connected to MB

Figure 6-23. Removing the Fan

9. Use a Phillips-head screwdriver to remove the 2 mounting screws that hold the Fan Assembly in place, and then remove the Fan Assembly.

The shape of the Mother Board and other components allow the screwdriver to reach the fan mounting screws.

Installing the Fan Assembly:

10. Install the replacement Fan Assembly and tighten the 2 mounting screws.
Torque these screws to 4.0 lbf · in (0.45 N · m).
11. Connect the fan cable to connector J1002 on the Mother Board.

Installing the VNA PCB Assembly:

12. Carefully reposition the VNA PCB Assembly over the Mother Board and prepare to secure it in place.
13. Using [Figure 6-22 on page 6-57](#), identify the locations of the eight (8) Phillips-head mounting screws that hold the VNA Assembly PCB in place. [Figure 6-21 on page 6-56](#) shows the 8 hexagonal standoffs on the Mother Board. The 8 VNA Assembly PCB screws attach to the 8 hexagonal standoffs in the Main PCB (Mother Board).

Installing the GPS Antenna SMA Connector:

If the GPS Receiver Module PCB (Option 31) is not installed, then skip ahead to [Step 14](#). If the GPS Receiver Module PCB is installed, then perform the following sub steps:

- a. Route the GPS Antenna Cable (with its SMA connector from the Main PCB) through the notch between the top connector panel and the PCB, and into its position in the top connector panel.
- b. Install the lock washer and then the nut.
- c. Use two 5/16 inch (~8 mm) wrenches to attach the GPS Antenna SMA connector to the top connector panel. Torque the nut to 7.5 lbf ·in (0.85 N ·m).

14. Carefully position the VNA PCB Assembly over the Main PCB and the eight (8) hex standoffs.

15. Fasten the VNA PCB Assembly into place using eight (8) Phillips-head screws. Torque these screws to 7.5 lbf ·in (0.85 N ·m).

Installing the Power Monitor PCB Assembly and Detector Connector:

16. If the Power Monitor PCB (Option 5) is not installed, then skip ahead to [Step 17](#). If the Power Monitor PCB is installed, then perform the following sub steps:

- a. Insert the Detector connector with the Flex Cable into the Detector hole on the top connector panel.
- b. The Flex Cable must oriented above the Connector. Reinstall and tighten the two M3 x 0.5 Kep Nuts using the 5.5mm angled-head open end wrench. Tighten firmly. These nuts have no torque specification.
- c. Carefully position the Power Module Assembly over its mounting standoffs.
- d. Use extreme care so as to not bend any of the header pins.
- e. Be careful to not offset the header pins by one row.
- f. Make sure that the pins are loosely but correctly positioned before proceeding.
- g. When perfectly aligned, press on each side of the header strip to mate the two connectors.
- h. When the Power Monitor PCB is fully seated, inspect Header connectors from the side to Make sure that all pins are correctly inserted and no pins are bent.
- i. Install the three (3) Phillips-head screws holding the Power Monitor PCB in place. Torque these screws to 7.5 lbf ·in (0.85 N ·m).
- j. Gently fold over the Flex Cable and insert it into the four-connector socket on the PCB.

Installing the Ext Trig BNC Connector and Dress Cables:

17. Reinstall the Ext Trig Input BNC connector in the top connector panel. Use the Tool T1451 socket to tighten the BNC Connector Dress Nut. The torque specification is 7.5 lbf ·in (0.85 N ·m).

18. Make sure that all cables are clear of the case edges.

19. Install a cable tie over the two coax cables and the RF semi-rigid to keep them in place.

Closing the Case:

20. Close the case as described in section [“Closing the Case” on page 6-24](#).

Installing Battery:

Refer to [Section 5-4 “Battery Pack Removal and Replacement” on page 5-3](#).

21. Install the Battery.

22. Install the Battery Door.

Restarting the Instrument:

23. Restart the instrument.

24. Perform a function check to verify all repairs and part replacements.

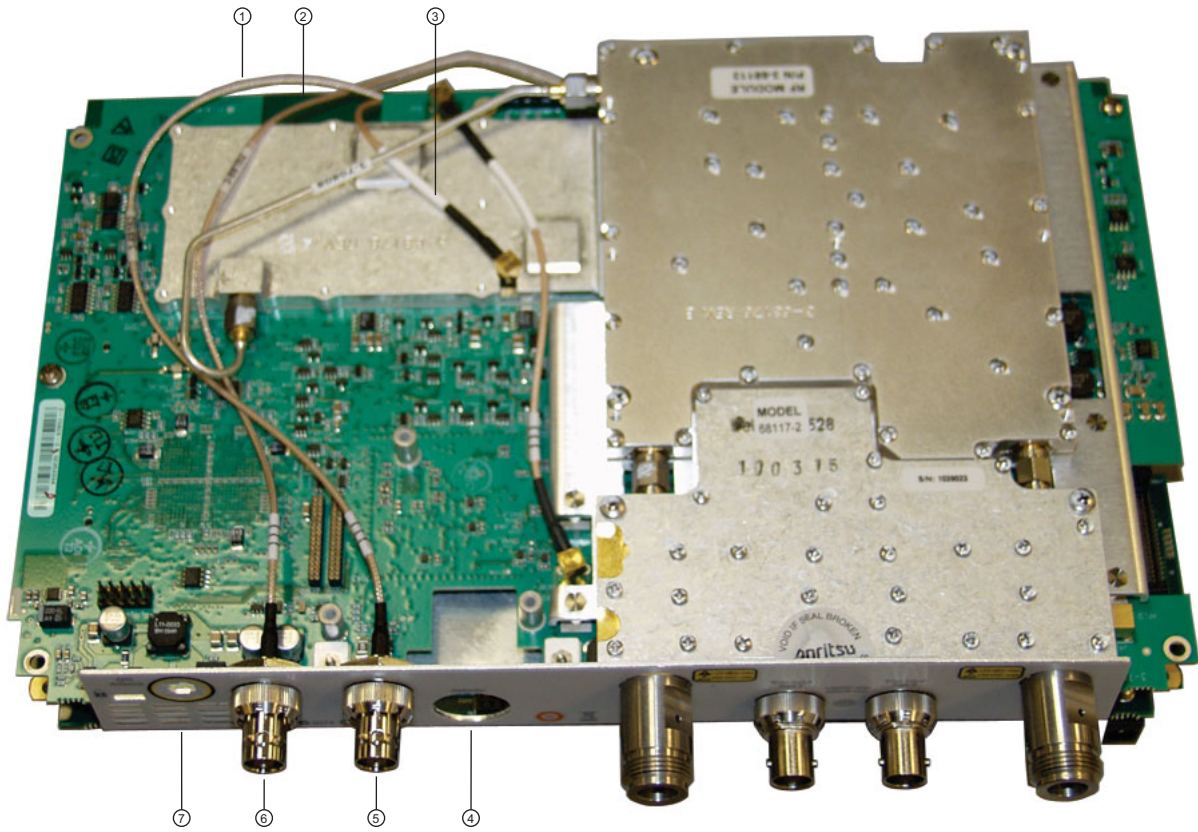

1. Cable, Ext Trig Input, to MB J3202
2. Cable, Ext Ref Input, to MB J2200
3. Cable, VNA Reference, 26 MHz, to MB J2201
4. Location of Power Monitor Connector (Option 5) or hole plug (Power Monitor option not installed)
5. External Trigger Input Connector
6. External Reference Input Connector
7. Location of GPS Antenna Connector (Option 31) or hole plug

Figure 6-24. Cables Connecting Main PCB (Mother Board) and VNA PCB (MS2028C shown)

Chapter 7 — Assembly Removal and Replacement, MS203xC

7-1 Introduction

This chapter describes the removal and replacement procedures for the various assemblies of VNA Master models MS2036C and MS2038C. Illustrations (drawings or photographs) in this manual may differ slightly from the instrument that you are servicing, but the basic removal and replacement functions will remain as specified. The illustrations are meant to provide assistance with identifying parts and their locations.

7-2 Electrostatic Discharge Prevention

An ESD safe work area and proper ESD handling procedures that conform to ANSI/ESD S20.20-1999 or ANSI/ESD S20.20-2007 is mandatory to avoid ESD damage when handling subassemblies or components found in the MS2036C or MS2038C VNA Master.

Warning	All electronic devices, components, and instruments can be damaged by electrostatic discharge. It is important to take preventative measures to protect the instrument and its internal subassemblies from electrostatic discharge.
----------------	---

7-3 Real Time Clock (RTC) Battery

Note	The Real Time Clock (RTC) battery is not field replaceable. The instrument must be returned to the factory for service.
-------------	---

7-4 Replaceable Parts, Assemblies, and Accessories

To ensure that the correct options are provided on the replacement assembly when ordering a Main PCB Assembly, all options that are installed on your instrument must be declared on the order. The installed options are listed on a label on the top of the MS203xC and can also be viewed in the System/Status display. For a list of replaceable parts, refer to [Table 1-7, “Replaceable Parts and Assemblies” on page 1-8](#).

7-5 Front Panel Components for VNA Master MS203xC

Figure 7-1 shows the major front panel components including the bezels, keypad Rubber Membranes, PCBs, and other inner case components.

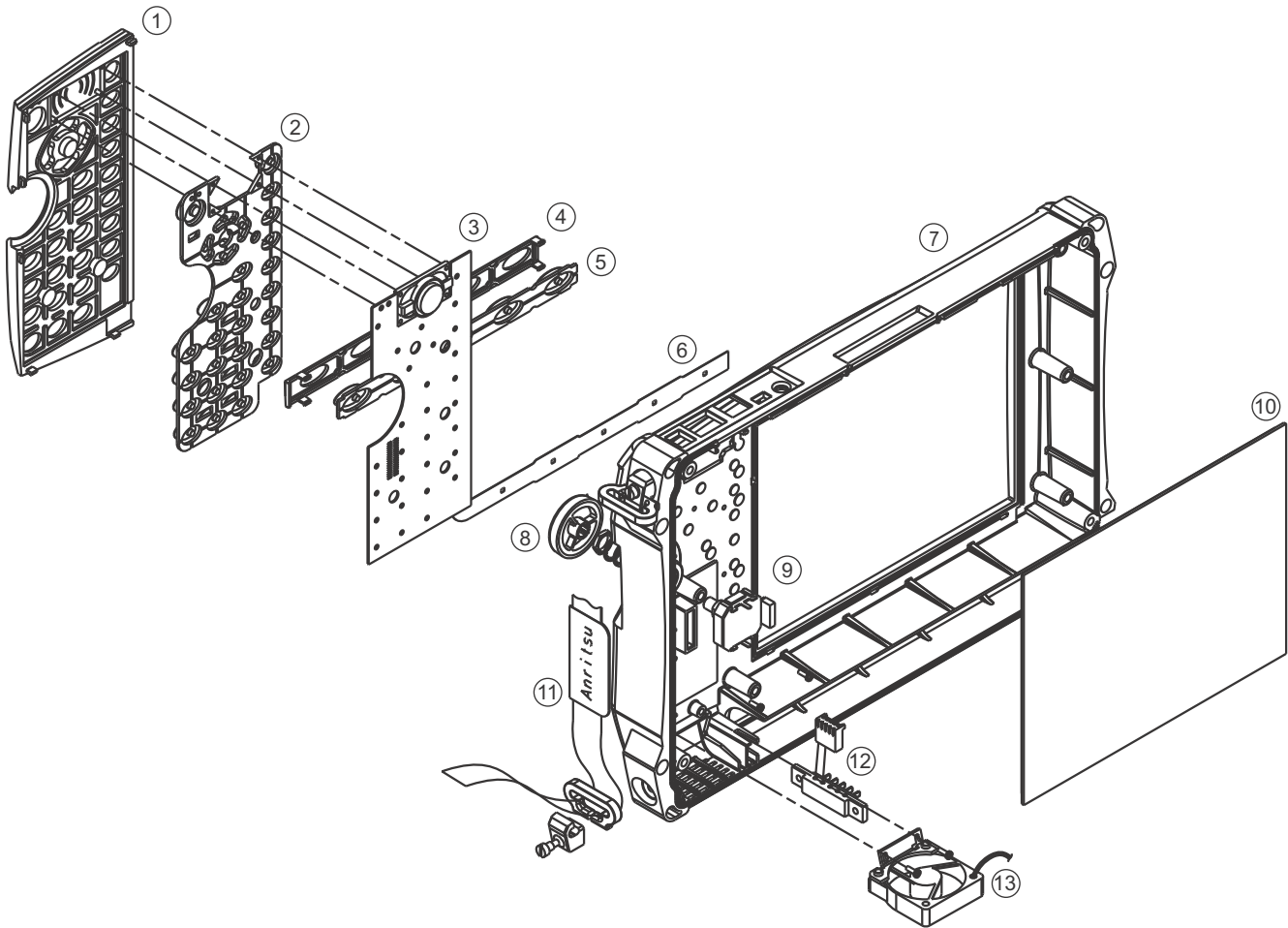

1. Main Keypad Switch Bezel
2. Main Keypad Switch Membrane
3. Main Keypad Switch PCB with installed speaker
4. Main Menu Switch Bezel
5. Main Menu Switch Membrane
6. Main Menu Switch Flex PCB connected to Main Keypad Switch PCB at connector J2
7. Case Front
8. Rotary Knob
9. Rotary Encoder with attached cable harness
10. LCD Clear Plastic Protector
11. Handle Carrying Strap
12. Battery Connector Contacts with attached cable harness
13. Cooling Fan with mounting bracket and attached cable harness.

Figure 7-1. Case Front Components Overview for MS203xC

7-6 Main Keypad Bezel for VNA Master MS203xC

Figure 7-2 shows the Main Keypad Bezel, the location of its locking tabs, and its relationship to the Main Keypad Rubber Membrane. The 8 submenu keys (main Menu) are part of this keypad.

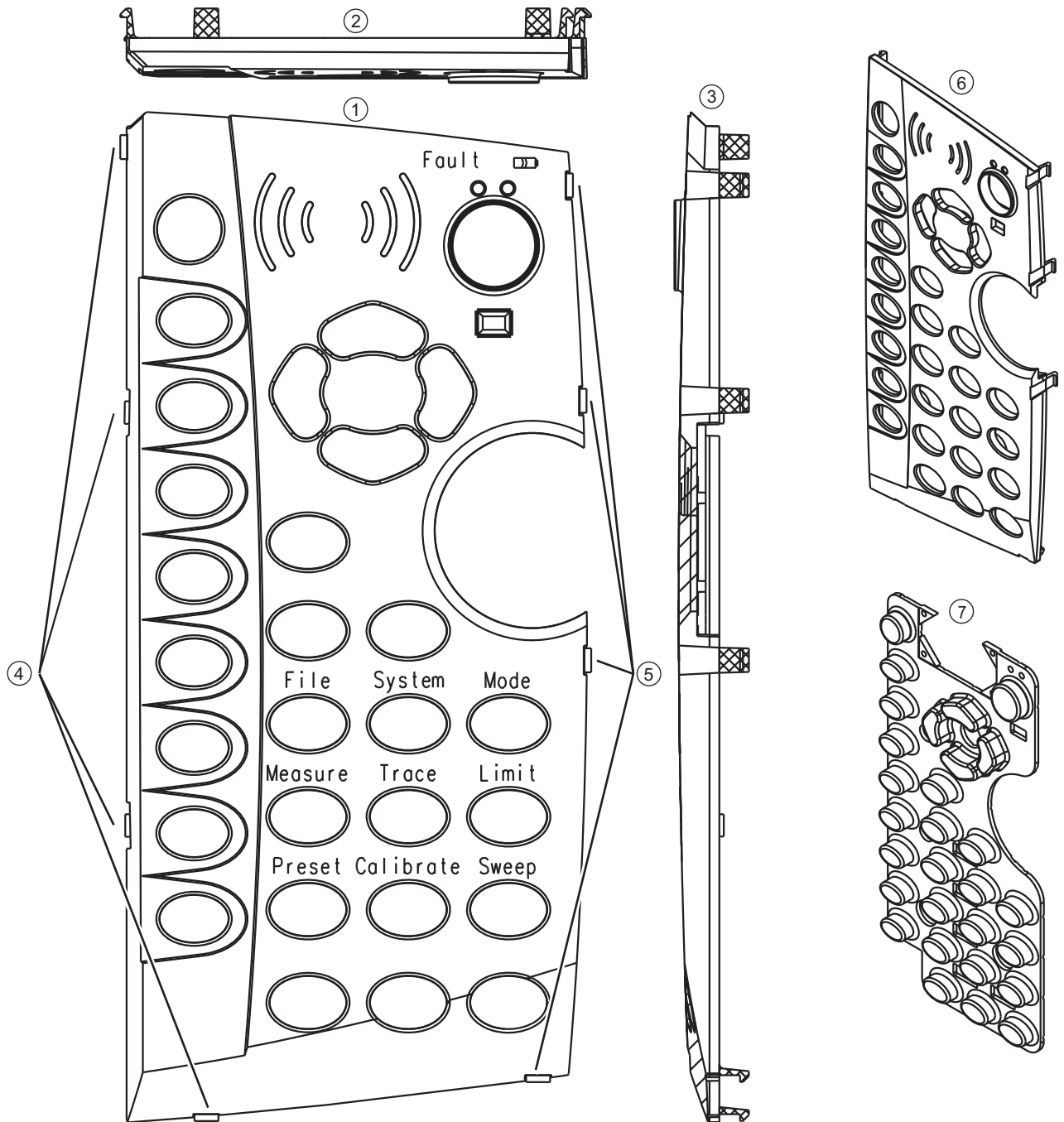

1. Main Keypad Bezel Front View
2. Top View
3. Side View
4. Left side locking tab locations
5. Right side locking tab locations
6. Three-Quarter View
7. Underlying Main Keypad Rubber Membrane

Figure 7-2. Main Keypad Bezel and Locking Tabs for MS203xC

7-7 Main Menu Keypad Bezel for VNA Master MS203xC

Figure 7-3 shows the Main Menu Keypad Bezel, the location of its locking tabs, and its orientation to the case. The Main Menu Keys may also be called Function Hard Keys.

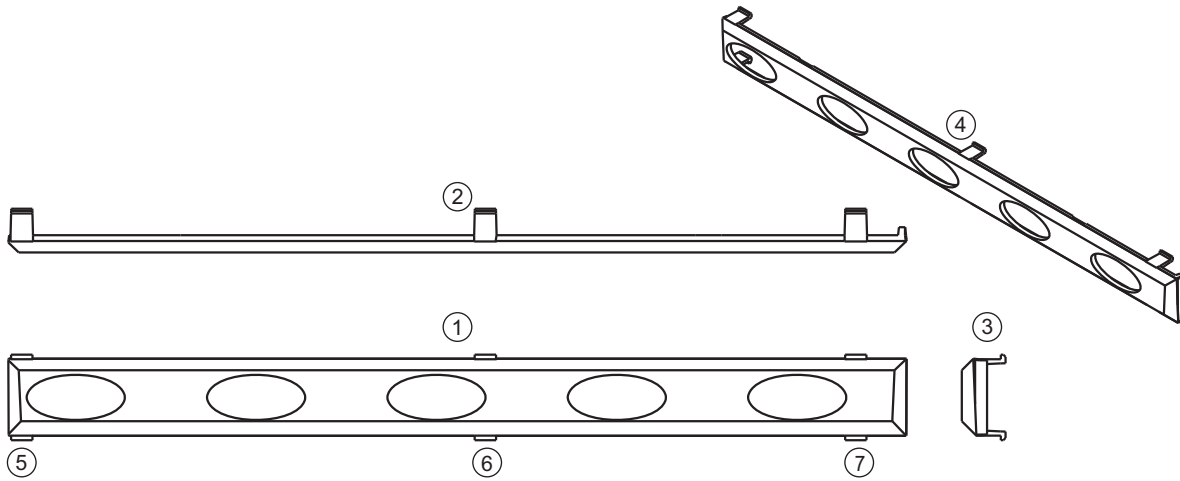

1. Main Menu Keypad Bezel Front View
2. Top View
3. Side View
4. Three-Quarter View
5. Locking tab location for the left end of the bezel which goes toward the left side of the case
6. Locking tab location for bezel center
7. Locking tab location for the right end of the bezel which goes toward the right side (handle side) of the case

Figure 7-3. Main Menu Keypad Bezel and Locking Tab Locations for MS203xC

7-8 Internal Anatomy of the VNA Master MS2036C

MS2036C View from Top Connector Panel

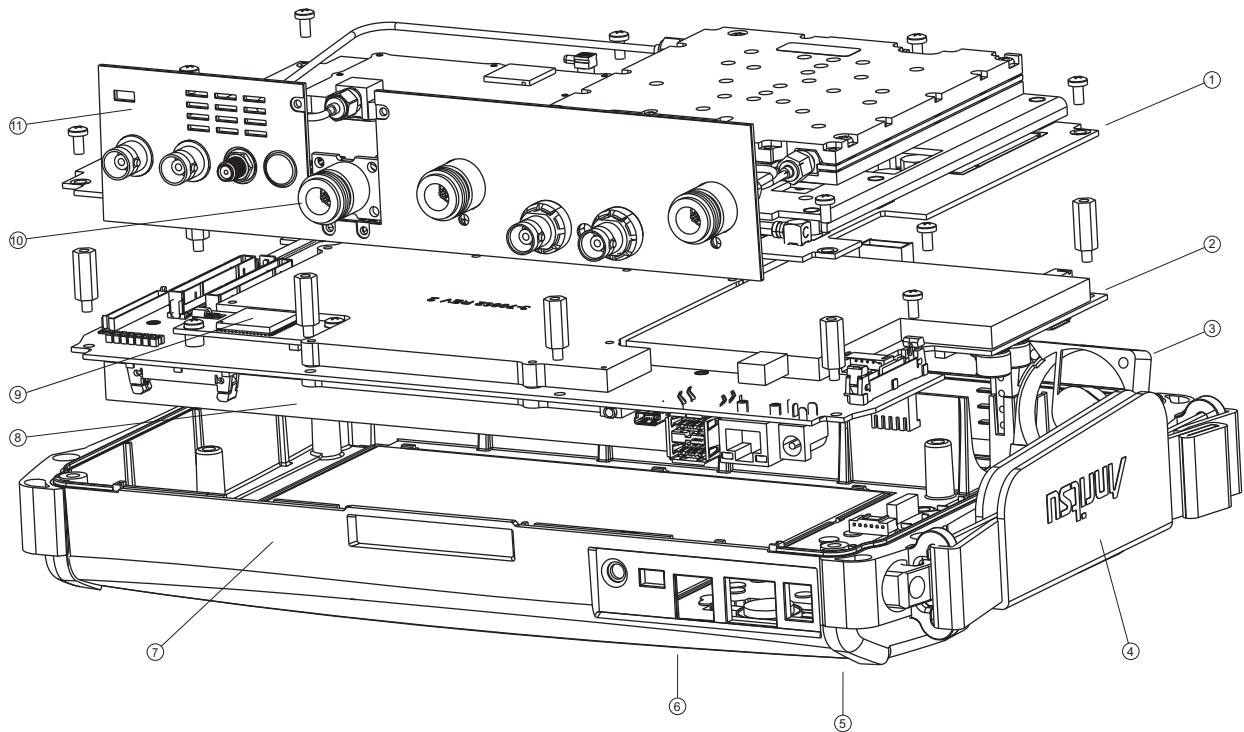

1. VNA PCB Assembly with N(f) Connectors
2. Main PCB Assembly
3. Cooling Fan Assembly
4. Hand Strap (mounted on Case Front)
5. Rotary Knob and Rotary Encoder (mounted on Case Front)
6. Main Keypad (mounted on Case Front)
7. Case Front
8. LCD Display (mounted on Main PCB Assembly)
9. GPS Module Option 31 PCB Assembly
10. N(f) Connector for Spectrum Analyzer
11. Connector Panel

Figure 7-4. VNA Master MS2036C Major Assemblies – Viewed from Top Connector Panel

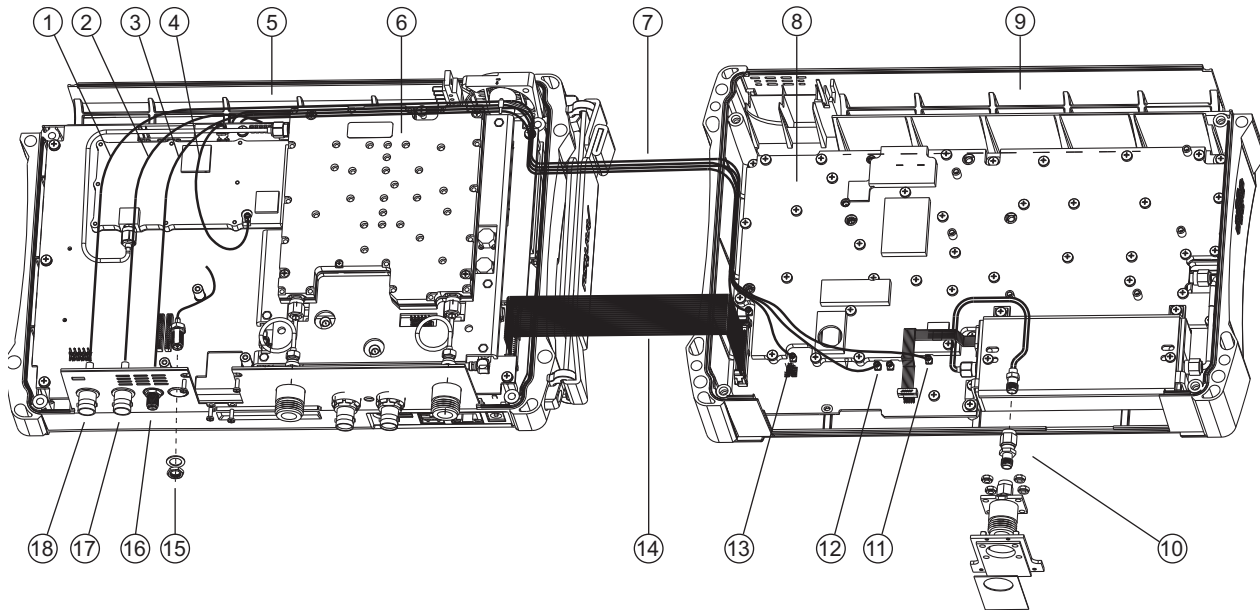
MS2036C Connections Front to Back**View for Joining Front and Back Case Assemblies**

1. BNC Cable Assembly, from External Reference Connector to Connector J6000 on SPA PCB
2. BNC Cable Assembly, from External Trigger Connector to Connector J3202 of Mother Board LCD Assembly
3. Cable, from 10 MHz Reference Out SMA Connector to Connector J6001 on SPA PCB
4. MCX Cable Assembly, Mother Board J2201 (26 MHz Out) to top shield of VNA Module at J7002
5. Front Case Assembly, with Mother Board Assembly and VNA Board Assembly
6. RF Module of VNA Board Assembly
7. 4 Cables Between Case Front and Case Back
8. SPA Board Assembly in Case Back
9. Back Case Assembly, with SPA Board Assembly
10. Spectrum Analyzer RF In Connector Assembly
11. MMCX Connector J4004, Receives Cable from J3203 (14.0 MHz IF) of Mother Board
12. MMCX Connector J6002, Receives Cable from J2200 (100 MHz In) of Mother Board
13. MMCX Connector J6000, Receives BNC Cable from External Reference Connector in Front Case Assembly
14. SMA Cable Assembly (ribbon cable) from Mother Board Connector J3000 to Connector J6001 of SPA Board
15. GPS Antenna Location (with Option 31)
16. 10 MHz Reference Out Connector (SMA)
17. External Trigger Connector (BNC)
18. External Reference Connector (BNC)

Figure 7-5. VNA Master MS2036C Major Assemblies – Connections Front to Back

7-9 Internal Anatomy of the VNA Master MS2038C

MS2038C View from Top Connector Panel

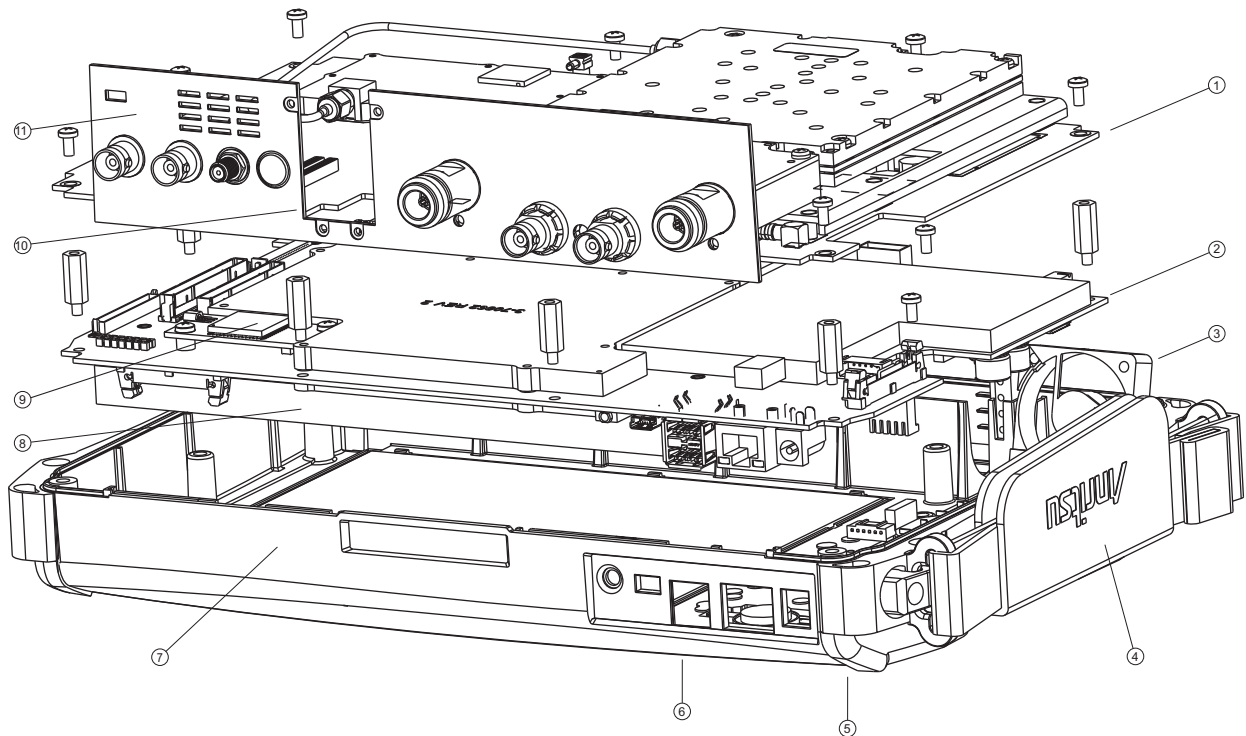

1. VNA PCB Assembly with N(f) Connectors
2. Main PCB Assembly
3. Cooling Fan Assembly
4. Hand Strap (mounted on Case Front)
5. Rotary Knob and Rotary Encoder (mounted on Case Front)
6. Main Keypad (mounted on Case Front)
7. Case Front
8. LCD Display (mounted on Main PCB Assembly)
9. GPS Module Option 31 PCB Assembly
10. Location of N(f) Connector for Spectrum Analyzer
11. Connector Panel

Figure 7-6. VNA Master MS2038C Major Assemblies – Viewed from Top Connector Panel

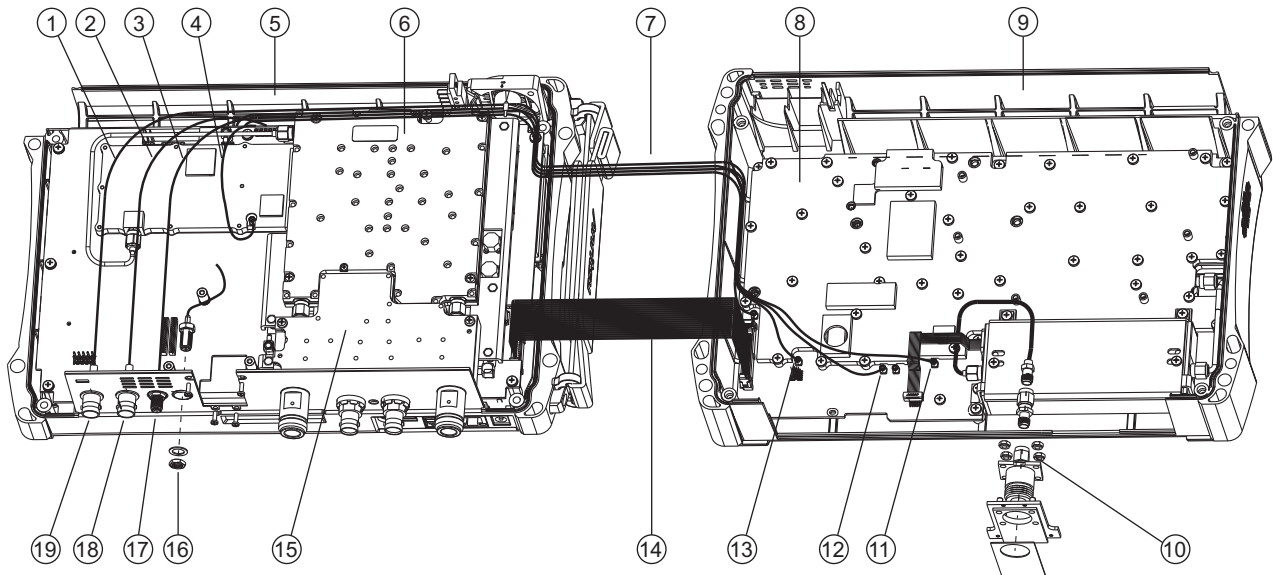
MS2038C Connections Front to Back**View for Joining Front and Back Case Assemblies**

1. BNC Cable Assembly, from External Reference Connector to Connector J6000 on SPA PCB
2. BNC Cable Assembly, from External Trigger Connector to Connector J3202 of Mother Board LCD Assembly
3. Cable, from 10 MHz Reference Out SMA Connector to Connector J6001 on SPA PCB
4. MCX Cable Assembly, Mother Board J2201 (26 MHz Out) to top shield of VNA Module at J7002
5. Front Case Assembly, with Mother Board Assembly and VNA Board Assembly
6. RF Module of VNA Board Assembly
7. 4 Cables Between Case Front and Case Back
8. SPA Board Assembly in Case Back
9. Back Case Assembly, with SPA Board Assembly
10. Spectrum Analyzer RF In Connector Assembly
11. MMCX Connector J4004, Receives Cable from J3203 (14.0 MHz IF) of Mother Board
12. MMCX Connector J6002, Receives Cable from J2200 (100 MHz In) of Mother Board
13. MMCX Connector J6000, Receives BNC Cable from External Reference Connector in Front Case Assembly
14. SMA Cable Assembly (ribbon cable) from Mother Board Connector J3000 to Connector J6001 of SPA Board
15. Microwave Module
16. GPS Antenna Location (with Option 31)
17. 10 MHz Reference Out Connector
18. External Trigger Connector
19. External Reference Connector

Figure 7-7. VNA Master MS2038C Major Assemblies – Connections Front to Back

MS203xC Case and Back Screws

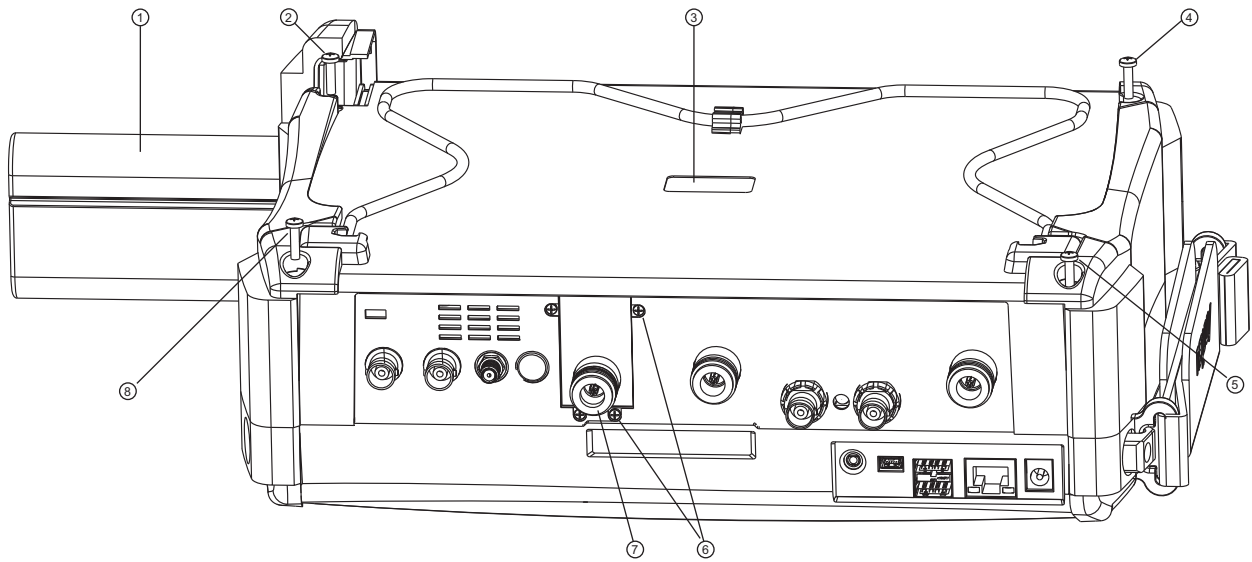

1. Battery
2. Case Back screw (1 of 4)
3. Recess for serial number label (serial number of SPA PCB)
4. Case Back screw (1 of 4)
5. Case Back screw (1 of 4)
6. Screws (4) to hold SPA RF In connector mounting plate to top connector panel
7. SPA RF In port (supplied with SPA PCB)
8. Case Back screw (1 of 4)

Figure 7-8. Case for MS203xC

7-10 Disassembly Sequence Overview

Outside Replacements

The following parts can be replaced without opening the case:

- Main Keypad Rubber Membrane
- Main Keypad PCB Assembly
- Main Menu Keypad Rubber Membrane
- Main Menu Keypad PCB Assembly
- Rotary Knob
- Hand Strap Handle
- Battery and Battery Door

Inside Replacements

Opening the instrument case provides access for the following replacement assemblies:

- Spectrum Analyzer PCB Assembly
- VNA PCB Assembly
- GPS Receiver Module, Option 31
- Rotary Encoder
- Main PCB Assembly
- LCD Display PCB Assembly
- LCD Backlight Power Inverter PCB Assembly
- Clear Plastic LCD Protector

Overview of Replaceable Component Parts

The following steps reduce the VNA Master MS203xC to its replaceable component parts:

1. Remove the Battery Door and the Battery.
2. Remove and replace the Handle Hand Strap.
3. Remove and replace the Rotary Encoder Knob.
4. Remove and replace the Main Menu Key (Function Hard Key) Keypad Bezel, Membrane, and PCB.
5. Remove and replace the Main (Numeric) Keypad Bezel, Membrane, and PCB.
6. Open the case and separate the Case Front and Case Back Assemblies
7. Disconnect (if installed) the GPS Antenna SMA connector and cable from the top connector panel.
8. Remove and replace the VNA PCB Assembly and the attached connector panel.
9. Remove and replace the Rotary Encoder from the case.
10. Disconnect the three (3) coaxial cables that are attached to the Main PCB Assembly
11. Remove and replace (if installed) the GPS Receiver Module PCB (Option 31) from the Main PCB Assembly.
12. Remove and replace the Main PCB Assembly.
13. Remove and replace the LCD Display Assembly from the Main PCB Assembly.
14. Remove and replace the Clear Plastic LCD Protector from the Case Front.

7-11 Replacing Main Keypad Components – 3-61362, 65027-3

This procedure provides instructions for removing and replacing the Main Keypad Plastic Bezel, the Main Keypad Rubber Membrane, and/or the underlying Main Keypad PCB. All keypad parts can be replaced without opening the MS203xC case.

Part Numbers

- 3-61363-1 – Main Keypad Plastic Bezel for either MS2036C or MS2038C instruments
- 3-61362 – Main Keypad Rubber Membrane for either MS2036C or MS2038C instruments
- 3-71027-3 – Main Keypad PCB for either MS2036C or MS2038C instruments

Procedure

Note Use a small piece of rubber or similar material to prevent scratches to the front panel and the switch bezels.

1. Place the instrument face up on a protected work surface, oriented with the top Connector Panel away from you.
2. Remove the Battery Door and the Battery. Refer to [Chapter 5, “Battery Information and Replacement”](#).

Removing Rotary Knob:

3. Using the medium flat blade screwdriver, remove the Rotary Knob by sliding it under the knob and levering it up gently.

Removing Main Keypad Bezel:

4. Eight (8) locking tabs hold the Main Keypad Bezel to the case as shown in [Figure 7-9](#).

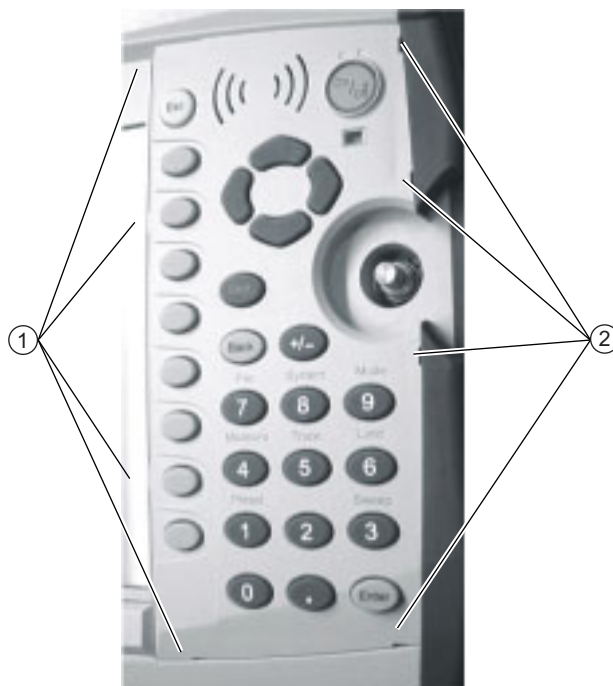

1. Location of Main Keypad Switch Bezel four (4) left side locking tabs
2. Location of four (4) right side locking tabs.

Figure 7-9. Main Keypad Bezel Locking Tab Locations

5. Using a small flat blade screwdriver and a piece of rubber as scratch protection, carefully pry the eight (8) Main Keypad Bezel locking tabs free of the main body of the case. The following tips help with the removal process:
 - The flat blade screwdriver width must be less than 3.5 mm (0.13 inch) wide and as thin as possible.
 - If available, recommended is a screwdriver made of fiberglass or other material that will not scratch the bezel.
 - As each locking tab releases, the bezel comes up a bit.
 - The basic technique is to position the protective piece of rubber (or similar material) next to the slot for scratch protection, press the screwdriver straight in between the case and the bezel, and then gently lever the screwdriver AWAY from the bezel.

Protecting Speaker and Remove Bezel:**Caution**

The Speaker sits on top of the Main Keypad PCB and is held in place by four locating pins on the inside of the keypad bezel around the speaker opening. When the keypad bezel is removed, the speaker is held only by the fragile connecting wires. Use extreme care not to damage the speaker wires when removing or replacing the keypad rubber Membrane or PCB.

6. When the eight locking tabs are released, lift the bezel carefully up, disengage the speaker from its mounting pins (it stays attached to the underlying Main Keypad PCB) and set the bezel aside.
7. If you are replacing more than the Main Keypad Bezel, then continue at [Step 8](#). If you are replacing only the Main Keypad Bezel, then perform the following sub steps:

Replacing Main Keypad Bezel:

- a. Replace Main Keypad Bezel by first centering it on the key membrane and the Speaker.
- b. Carefully align the speaker mounting pins of the bezel with the holes in the speaker assembly.
- c. Work your way around the bezel gradually positioning each Locking Tab into its slot. Take care not to bend any Locking Tab.
- d. When all are correctly inserted, go around again snapping each tab into place.
- e. When complete, each button should protrude approximately 1.5 mm to 2 mm above the bezel.

Installing Battery:

Refer to [Section 5-4 “Battery Pack Removal and Replacement”](#) on page 5-3.

- f. Install the Battery.
- g. Install the Battery Door.

Restarting the Instrument:

- h. Restart the instrument.
- i. Perform a function check for each button on the Main Keypad and the Main Menu Keypad.

Replacement Options

8. At this point, your options are to remove and replace the Main Keypad Rubber Membrane, remove and replace the Main Keypad PCB, or both of these parts. Each procedure is described in the following sections.

7-12 Removing Main Keypad Rubber Membrane

9. Protecting the Speaker wires, start at the bottom of the Main Keypad Rubber Membrane and lift it up.
10. Hold the edge of the Speaker with one hand and remove the Membrane from one side and then remove the Membrane from the other side.
11. Again starting at the bottom, lay in the replacement Membrane starting at the top of the keypad area.
12. At the top, lift up the left edge of the Speaker and lay in the Membrane.
13. Again at the top, lift up the right edge of the Speaker and lay in the Membrane.
14. When complete, the Speaker should sit ON TOP of the Membrane.
15. Make sure that the Main Menu Keypad ribbon cable is still securely connected.
16. If you are not replacing the Main Keypad PCB, then skip ahead to [“Installing Main Keypad Bezel:” on page 7-14](#) and replace the Keypad Bezel.

Removing Main Keypad PCB:

17. At the bottom left corner of the Main Keypad PCB, remove the drop of silicon sealant holding the ZIF SMT Flip Door connector (J2) shut. The narrow ribbon cable in the connector is the Main Menu Keypad Flex PCB.
18. Lift the connector cover open, and gently lift out the Main Menu Keypad Flex PCB. The Flex PCB stays in the case, but must be protected and kept out of the way for the following operations .

Note Do not crimp, fold, or puncture the Main Menu Keypad Flex PCB.
--

19. Note that a 16-pin header connector is between the Main Keypad PCB (connector J1) and the Mother Board (Main PCB) inside the case at connector J5006. The header pin connector is shown as item 4 in [Figure 7-30 on page 7-57](#).
20. Protecting the speaker and its connections on the PCB, gently pry up the PCB as the header pins disconnect from the underlying the Main PCB Assembly.
21. Set the Main Keypad PCB aside and install the replacement PCB. The replacement unit should come with an installed 16-pin header connector. The longer pins on the header go into the Main Keypad PCB. The short pins will ultimately connect through the front cover mounting slot into the Main PCB Assembly. Inspect the header pins to make sure that they are straight and evenly spaced.

If the 16-pin header connector is not included with the replacement PCB, then remove the existing 16-pin header from the old PCB and install it into the replacement unit. As stated, the long pins go into the Main Keypad PCB, and the short pins go through the case slot into the Main PCB.
22. Carefully position the replacement Main Keypad PCB on the case with the 16-pin header going into the case slot.
23. When the position is verified, and you are sure that the header is correctly located, gently press the PCB into place, making full contact with the Main PCB Assembly.
24. Open the connector Flip Latch in the lower left corner of the PCB and insert the Main Menu Keypad Flex PCB into the connector (J2). Push the connector Flip Latch down and add a drop of RTV (Room Temperature Vulcanizing silicon sealant) to hold the door shut. Allow ample time for the sealant to set.

Anritsu Part Number: 3-783-1102 ñ RTV Silicon Sealant
25. Either replace or reinstall the Main Keypad Rubber Membrane by following [Step 11 on page 7-14](#) to [Step 15 on page 7-14](#).

Installing Main Keypad Bezel:

26. Replace Main Keypad Bezel by first centering it on the key membrane and the Speaker.
27. Carefully align the speaker mounting pins of the bezel with the holes in the speaker assembly.

28. Work your way around the bezel gradually positioning each Locking Tab into its slot. Take care not to bend any Locking Tab.
29. When all are correctly inserted, go around again snapping each tab into place.
30. When complete, each button should protrude approximately 1.5 mm to 2 mm above the bezel.

Installing Battery:

Refer to [Section 5-4 “Battery Pack Removal and Replacement”](#) on page 5-3.

31. Install the Battery.
32. Install the Battery Door.

Restarting the Instrument:

33. Restart the instrument.
34. Perform a function check for each button on the Main Keypad and the Main Menu Keypad.

7-13 Replacing Main Menu Keypad Rubber Membrane – 3-61361

This procedure provides instructions for removing and replacing the Main Menu Keypad Rubber Membrane. All keypad parts can be replaced without opening the MS203xC case.

If both the rubber membrane and the underlying Main Menu Keypad Flex PCB must be replaced, then the Main Keypad Bezel must also be removed. Do not use this procedure, but skip to the procedure in [Section 7-14 – Replacing Main Menu Keypad Components – 3-61361, 61333-3 on page 7-18](#).

Part Numbers

- 3-61361 – Main Menu Keypad Rubber Membrane for MS2036C and MS2038C instruments

Procedure

Note	Use a small piece of rubber or similar material to prevent scratches to the front panel and the switch bezel.
-------------	---

1. Place the instrument face up on a protected work surface oriented with the top Connector Panel away from you.
2. Remove the Battery Door and the Battery.

Removing Main Menu Keypad Bezel:

3. Six (6) locking tabs hold the Main Menu Keypad Bezel to the case as shown in [Figure 7-10](#)

Caution	Exercise extreme caution working around the LCD Display. Do not press in the middle of the display nor set any tools on it.
----------------	---

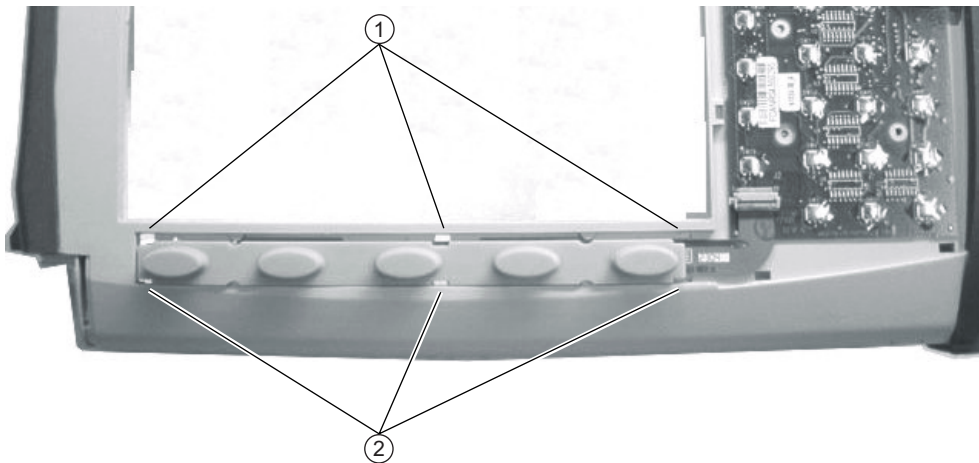

1. Location of three (3) upper locking tabs on the Main Menu Keypad Bezel (not shown) and the Keypad Rubber Membrane.
2. Location of three (3) lower locking tabs.

Figure 7-10. Locking Tab Locations for Main Menu Keypad Bezel

4. Using a small flat blade screwdriver and a small piece of rubber or similar material, carefully pry the six (6) Main Menu Keypad Bezel locking tabs free from the case. The following tips help with the removal process:

- The flat blade screwdriver tip must be less than 3.5 mm (0.13 inch) wide and as thin as possible. If available, recommended is a screwdriver made of fiberglass or other material that will not scratch the bezel.

- As each locking tab releases, the bezel comes up a bit.
- The basic technique is to move the protective piece of rubber (or similar material) next to the slot, press the screwdriver straight in between the case and the bezel, and then gently lever the screwdriver AWAY from the bezel using the rubber as protection for the case finish.

5. When the six (6) locking tabs are released, lift the bezel up and set it aside.

Replacing Main Menu Keypad Rubber Membrane:

6. Lift the Main Menu Keypad Rubber Membrane out of the case and set it aside, revealing the underlying Main Menu Keypad Flex PCB.

Caution	Exercise extreme caution working around the Main Menu Keypad ribbon cable. Do not touch it with a screw driver or other tool.
----------------	---

7. Insert the replacement Main Menu Keypad Rubber Membrane into the case slot, making sure that the center Membrane latch cutouts correctly match up with the latch slots.

Installing Main Menu Keypad Bezel:

8. Replace the Main Menu Keypad Bezel by first correctly positioning it over its mounting slot, making sure that the latches at the very end of the bezel are to the left (when facing the instrument).
9. Work your way around the bezel gradually positioning each Locking Tab into its slot. Take care not to bend any Locking Tab.
10. When all tabs are correctly inserted, go around again snapping each tab into place.
11. When complete, each membrane button should protrude approximately 1.5 mm to 2 mm above the bezel.

Installing Battery:

Refer to [Section 5-4 “Battery Pack Removal and Replacement” on page 5-3](#).

12. Install the Battery.
13. Install the Battery Door.

Restarting the Instrument:

14. Restart the instrument.
15. Perform a function check for each button on the Main Keypad.

7-14 Replacing Main Menu Keypad Components – 3-61361, 61333-3

This procedure provides instructions for removing and replacing both the Main Menu Keypad Rubber Membrane and the underlying Main Menu Keypad Flex PCB and is written with the assumption that the Main Keypad PCB will not be replaced. All keypad parts can be replaced without opening the MS203xC case. If only the Main Menu Keypad Rubber Membrane is to be replaced (not the Main Menu Keypad Flex PCB), then use the prior procedure in [Section 7-13 – Replacing Main Menu Keypad Rubber Membrane – 3-61361 on page 7-16](#)

Part Numbers

- 3-61361 – Main Menu Keypad Rubber Membrane for MS2036C and MS2038C instruments
- 61333-3 – Main Menu Keypad Flex PCB for MS2036C and MS2038C instruments

Procedure

Note	Use a small piece of rubber or similar material to prevent scratches to the front panel and the switch bezel.
-------------	---

1. Place the instrument face up on a protected work surface oriented with the top Connector Panel away from you.
2. Remove the Battery Door and the Battery.

Removing Rotary Knob:

3. Remove the Rotary Knob by using a medium flat blade screwdriver and a small piece of gasket or rubber as anti scratch material.
4. Slide the screwdriver under the Knob, and gently lever it the Knob up and off of its shaft.

Removing Main Keypad Bezel:

5. The Main Keypad Bezel and Membrane must be removed to access the connector on the Main Keypad PCB.

The Main Keypad PCB does not need to be removed in order to service the Main Menu Keypad assembly.

6. Eight (8) locking tabs hold the Main Keypad Bezel to the case as shown in [Figure 7-11](#)

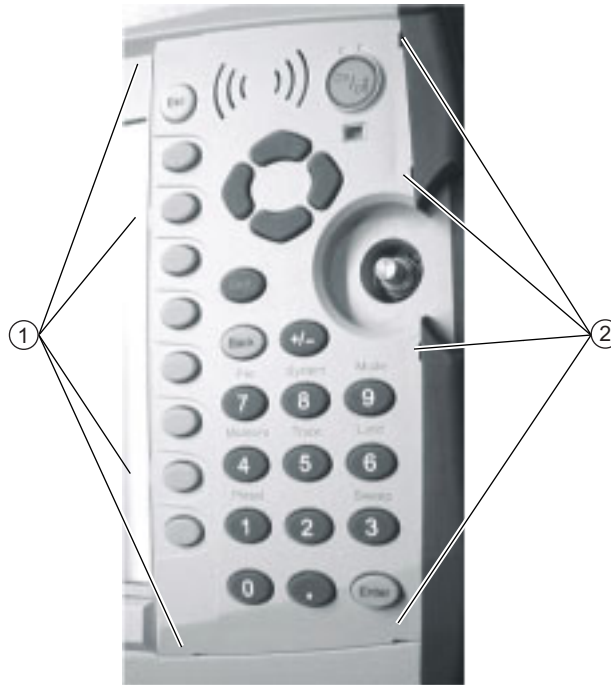

1. Location of four (4) left side locking tabs on the Main Keypad Switch Bezel.
2. Location of four (4) right side locking tabs.

Figure 7-11. Locking Tab Locations for Main Keypad Bezel

7. Using a small flat blade screwdriver and a small piece of rubber or similar material, carefully pry the eight (8) Main Keypad Bezel locking tabs free of the main body of the case. The following tips help with the removal process:

- The flat blade screwdriver width must be less than 3.5 mm (0.13 inch) wide and as thin as possible. If available, recommended is a screwdriver made of fiberglass or other material that will not scratch the bezel.
- As each locking tab releases, the bezel comes up a bit.
- The basic technique is to move the protective piece of rubber (or similar material) next to the slot, press the screwdriver straight in between the case and the bezel, and then gently lever the screwdriver AWAY from the bezel using the rubber as protection for the case finish.

Protecting Speaker Removing Bezel:

8. When the eight locking tabs are released, lift the bezel carefully up, disengage the speaker from its mounting pins (it stays attached to the underlying Main Keypad PCB, and set the bezel aside.

Caution

The Speaker sits on top of the Main Keypad PCB and is held in place by four locating pins on the inside of the keypad bezel around the speaker opening. When the keypad bezel is removed, the speaker is held only by the fragile connecting wires. Use care not to damage the speaker wires when removing or replacing the keypad rubber Membrane or PCB.

9. Protecting the Speakers wires, start at the bottom of the Main Keypad Rubber Membrane and lift it up.

7-14 Replacing Main Menu Keypad Components – 3-61361, 61333-3 Assembly Removal and Replacement,

10. Hold the edge of the Speaker with one hand and remove the Membrane from one side and then remove the Membrane from the other side, exposing the Main Keypad PCB.

Removing Main Menu Keypad Bezel:

Caution Exercise extreme caution working around the LCD Display. Do not press in the middle of the display nor set any tools on it.

11. Six (6) locking tabs hold the Main Menu Keypad Bezel to the case as shown in [Figure 7-10](#)

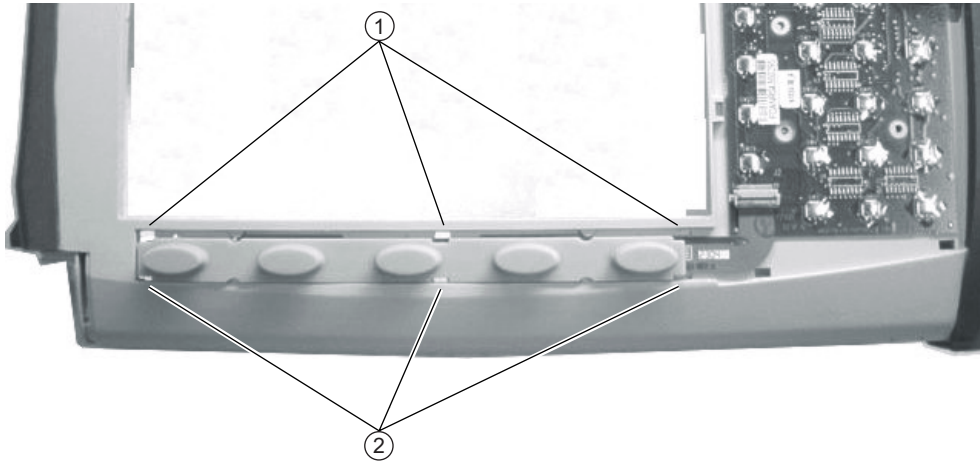

1. Location of three (3) upper locking tabs on the Main Menu Keypad Bezel (not shown) and the Keypad Rubber Membrane.
2. Location of three (3) lower locking tabs.

Figure 7-12. Locking Tab Locations for Main Menu Keypad Bezel

12. Using a small flat blade screwdriver and a small piece of rubber or similar material, carefully pry the six (6) Main Menu Keypad Bezel locking tabs free from the case. The following tips help with the removal process:
 - The flat blade screwdriver tip must be less than 3.5 mm (0.13 inch) wide and as thin as possible. If available, recommended is a screwdriver made of fiberglass or other material that will not scratch the bezel.
 - As each locking tab releases, the bezel comes up a bit.
 - The basic technique is to move the protective piece of rubber (or similar material) next to the slot, press the screwdriver straight in between the case and the bezel, and then gently lever the screwdriver AWAY from the bezel using the rubber as protection for the case finish.
13. When the six (6) locking tabs are released, lift the bezel up and set it aside.

Removing Main Menu Keypad Rubber Membrane and Flex PCB:

14. Lift the Main Menu Keypad Rubber Membrane out of the case and set it aside, revealing the underlying Main Menu Keypad Flex PCB.

Caution Exercise extreme caution working around the Main Menu Keypad ribbon cable. Do not touch it with a screw driver or other tool.

15. The Main Menu Keypad Flex PCB is connected to the Main Keypad PCB by a ZIF (Zero Insertion Force) “Flip Lock” SMF connector (J2) on the Main Keypad PCB.
16. The Connector Flip Lock is help in place with a drop of silicon sealant.

17. Using a plastic or similar scraper, scrape the sealant off the connector, and gently pry up the connector latch, freeing the Main Menu Keypad Flex PCB.
18. Remove and set aside the old Main Menu Keypad Flex PCB.

Caution The two keypad PCBs are fragile. Handle them with great care.
--

Replacing Main Menu Keypad Components:

19. Insert the replacement Main Menu Keypad Flex PCB into its slot.
20. Gently feed the right end of the Main Menu Flex PCB into the open Flip Lock connector (J2) and when positioned correctly, snap the Lock into position.
21. Apply a drop of silicon sealant to the Flip Lock and the underlying Main Menu Keypad Flex PCB. The sealant drop should not protrude more than 2 mm above the top of the connector.
22. Allow ample time for the sealant to set before proceeding.
23. Insert the replacement Main Menu Keypad Rubber Membrane into the case slot, making sure that the Membrane correctly aligns with the ribbon cable.

Note that the membrane can go in only one way, with the center slots offset to the right.
24. Replace the Main Menu Keypad Bezel (new or used) making sure that it has the correct orientation.
 - The bezel end with two latches goes towards the left side of the instrument.
 - The bezel end with two inset latches goes toward the right side of the instrument.
25. Work your way around the bezel gradually getting each Locking Tab into its slot. Take care not to bend any locking tab.
26. When all locking tabs are correctly inserted, go around again snapping each tab into place.
27. When complete, each Main Menu button should protrude approximately 1.5 mm to 2 mm above the bezel.

Installing Main Keypad Rubber Membrane and Bezel:

28. Starting at the bottom of the Main Keypad, lay in the Main Keypad Rubber Membrane working towards the top.
29. At the top, lift up each edge of the Speaker and lay in the Membrane.
30. When complete, the Speaker should sit ON TOP of the Membrane.
31. Make sure that the Main Menu Keypad ribbon cable is still securely connected.
32. Replace the Main Keypad Bezel by first centering it on the keys and the Speaker.
33. Work your way around the bezel gradually positioning each Locking Tab into its slot. Take care not to bend any Locking Tab.
34. When all locking tabs are correctly inserted, go around again snapping each tab into place.
35. When complete, each button should protrude approximately 1.5 mm to 2 mm above the bezel.

Installing Rotary Knob:

36. Turn the instrument and install the Rotary Knob. There is no specific orientation for the Knob.

Installing Battery:

Refer to [Section 5-4 “Battery Pack Removal and Replacement” on page 5-3.](#)

37. Install the Battery.
38. Install the Battery Door.

Restarting the Instrument:

39. Restart the instrument.
40. Perform a function check for each button on the Main Keypad and the Main Menu Keypad.

7-15 Replacing Hand Strap – 3-61470

This procedure provides instructions for replacing the right side Hand Strap using existing hardware. The case does not need to be opened for this procedure.

Part Numbers

- 3-61470 – Hand Strap

Procedure

1. Place the instrument face up on a protected work surface orientated with the top Connector Panel toward the right.
2. Using the flat blade screwdriver, remove the two M3 Slotted Screws holding the two Plastic Ring Holders to the case.
3. Orient the strap so that the word “Anritsu” reads correctly.
4. Capture one Handle End Ring with the Ring Holder and screw into place.
5. Making sure that the strap is not twisted, capture the remaining ring with the Ring Holder and screw it into place.

7-16 Replacing Rotary Knob – 3-61360-2

This procedure covers removing and replacing the Rotary Knob. The case does not need to be opened for this procedure. Note that this part does not include the Rotary Encoder. To replace the Rotary Encoder, refer to [Section 7-21 – Replacing Rotary Encoder – 3-410-101 on page 7-45](#).

Part Numbers

- 3-61360-2 – Rotary Knob
 - For MS2036C and MS2038C instruments
 - Does not include the 3-410-101 – Rotary Encoder

Procedure

1. Use a medium flat blade screwdriver and a small protective piece of rubber to remove the Rotary Knob.
2. Position the rubber piece next to the Knob, and slide in the screwdriver between the Knob and the Case.
3. Gentle lever the Knob up and off of its mounting shaft.
4. Position the replacement Knob over the shaft and press into place. There is no required orientation of the Knob.

7-17 Opening the Instrument Case

This procedure provides instructions for opening the MS203xC VNA Master case. With the case opened, the internal assemblies can be removed and replaced, as described in the sections that follow opening the case.

Procedure

1. Stand the VNA Master upright and use a Phillips screwdriver to remove the 4 screws that secure the SPA RF In connector support plate to the top connector panel. Refer to item 6 in [Figure 7-8 on page 7-9](#).
 - a. The SPA RF In connector cable and its support plate are attached to the SPA PCB, which is mounted into the case back.
 - b. All of the remaining connectors and the top connector panel are mounted to the VNA Assembly, which remains in the case front.
 - c. Retain the screws for reassembly.
2. As shown in [Figure 7-13](#), place the VNA Master MS203xC face down on a clean, stable work surface that will not scratch the front panel. Refer also to [Figure 7-8 on page 7-9](#).
3. Remove the battery access door and battery:
Refer to [Section 5-4 – Battery Pack Removal and Replacement on page 5-3](#).
4. Use a Phillips screwdriver to remove the four (4) Pan Head Phillips-head screws securing the two Case halves together.

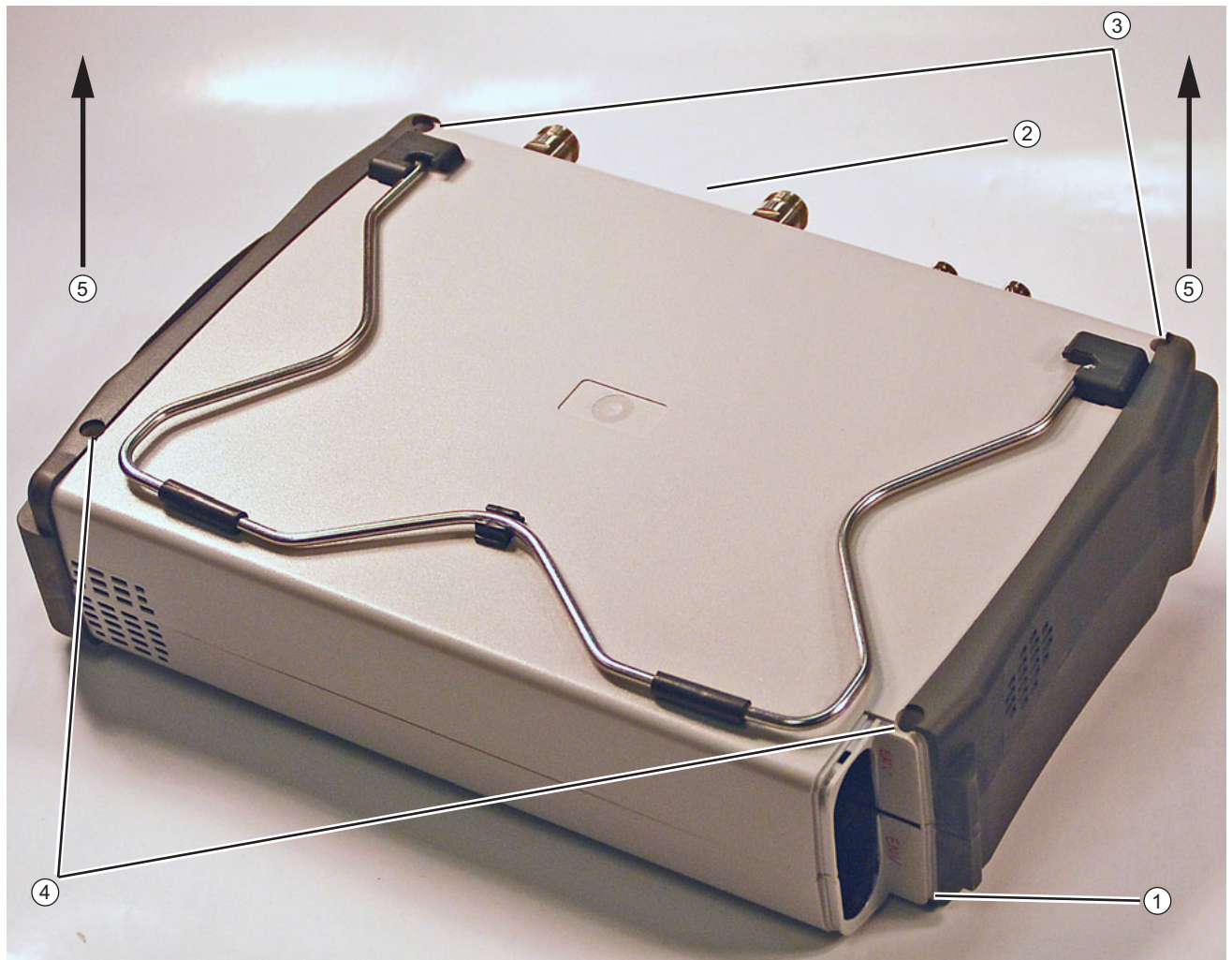

1. Remove Battery Access Door and Battery.
2. Orient case with connector panel as shown.
3. Remove two (2) Phillips-head screws at top.
4. Remove two (2) Phillips-head screws at bottom.
5. At both ends of the Case Rear, lift up both ends evenly.

The top connector panel stays with the Case Front Assembly.

Figure 7-13. Opening the Case

5. Carefully lift up on the sides of the case, as shown, and begin to separate the two halves. The top connector panel slides in grooves of the case back until the case halves are far enough apart to separate them.
6. As shown in [Figure 7-5 on page 7-6](#) and [Figure 7-7 on page 7-8](#), several cables connect between the front case and the back case.
7. Using care to avoid stress on the cables, pivot the case back as if it were hinged to the case front along the edge with the handle (carrying strap), and lay the case back (with SPA PCB face up) next to the case front.
8. Disconnect the Spectrum Analyzer cable assembly (ribbon cable, item 14 in [Figure 7-5](#), and item 14 in [Figure 7-7](#)) from connector J5001 of the SPA board in the back case. For a visual reference with all cables connected, refer to [Figure 7-14 on page 7-26](#).
 - a. Snap open the cable clamp first (shown open in [Figure 7-16 on page 7-30](#)).

- b. Spread the latch arms on the connector block, then pull out the cable connection.

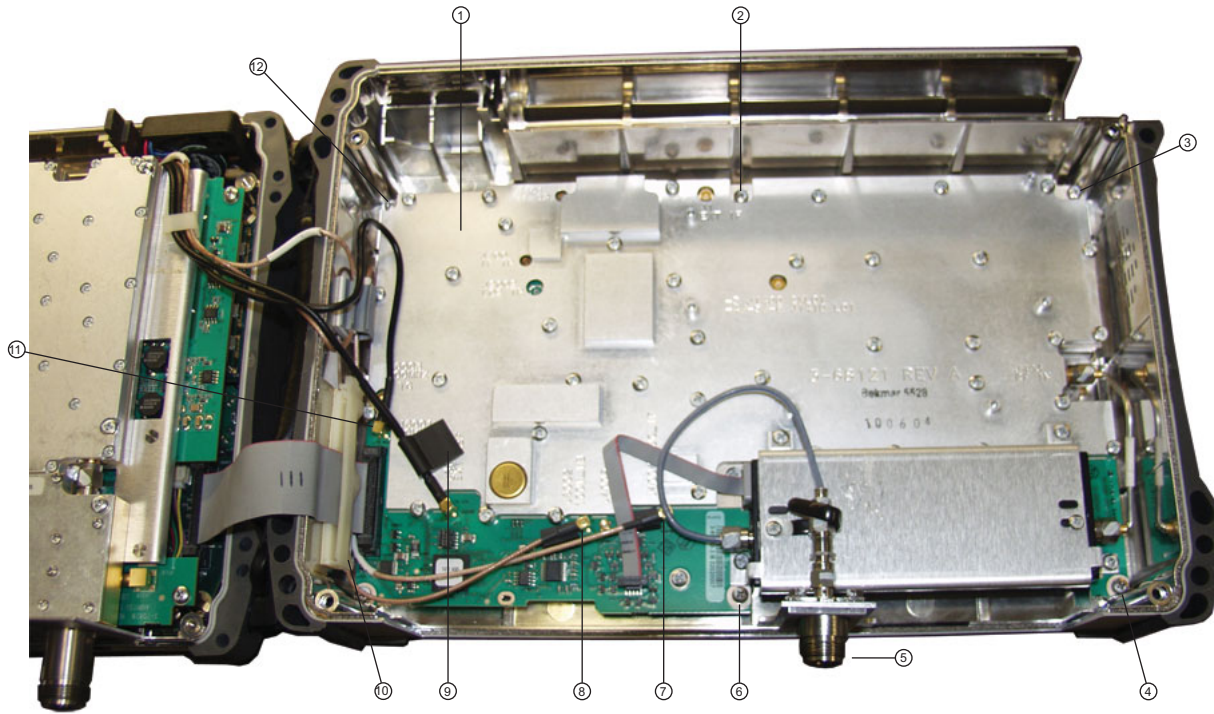

1. PCB
2. Screw (1 of 6 holding PCB to case back)
3. Screw (1 of 6 holding PCB to case back)
4. Screw (1 of 6 holding PCB to case back)
5. SPA RF In Connector (protrudes through connector panel of VAN Assembly when instrument is assembled)
6. Screw (1 of 6 holding PCB to case back)
7. MMCX Connector J4004, 140 MHz IF
8. Connector J6002, 100 MHz to MB (Mother Board)
9. Connector J6000, External Reference In
10. Screw (1 of 6 holding PCB to case back)
11. Connector J6001, 10 MHz Reference Out, located adjacent to J5006 (for ribbon cable)
12. Screw (1 of 6 holding PCB to case back)

Figure 7-14. SPA PCB in Case Back – Cables Connected

9. Snap open the other cable clamp in the back case, and then use needle-nose pliers to disconnect the four single cables from MMCX connectors J6000, J6001, J6002, and J4004.
 - a. J6000 (item 9 in Figure 7-14) is for the External Reference cable from the Ext. Ref. connector on the top connector panel (attached to the VNA Assembly).
 - b. J6001 (item 11 in Figure 7-14) is for the 10 MHz Ref Out connector on the top connector panel (attached to the VNA Assembly).
 - c. J6002 (item 8 in Figure 7-14) is for the 100 MHz In connector. The other end is connected to J2200 on the Mother Board.
 - d. J4004 (item 7 in Figure 7-14) is for the 140 MHz IF connector. The other end is connected to J3203 on the Mother Board.

10. The two halves of the instrument can now be safely separated. The **Case Back Assembly** contains the Spectrum Analyzer (SPA) board. The **Case Front Assembly** contains all of the other serviceable parts.

11. Refer to the following sections to remove and replace specific components of the instrument:
 - [Section 7-18 “Replacing SPA Module Assembly” on page 7-28](#)
 - [Section 7-19 “Replacing VNA PCB Assembly” on page 7-33](#)
 - [Section 7-20 “Replacing GPS Receiver Module \(Option 31\) – ND70320” on page 7-41](#)
 - [Section 7-21 “Replacing Rotary Encoder – 3-410-101” on page 7-45](#)
 - [Section 7-22 “Removing Main PCB Assembly” on page 7-50](#)
 - [Section 7-23 “Replacing Main PCB Assembly – ND72086, ND72087” on page 7-56](#)
 - [Section 7-24 “Replacing LCD Display – 3-15-154” on page 7-59](#)
 - [Section 7-25 “Replacing Clear Plastic LCD Protector – 3-61368” on page 7-61](#)
 - [Section 7-26 “Installing Main PCB and Reassembling Instrument” on page 7-62](#)
 - [Section 7-27 “Replacing Fan Assembly – ND70948” on page 7-72](#)

Caution	Proper routing of the cables is important for instrument performance and for being able to reassemble the case halves.
----------------	--

Closing the Case

1. With the **Case Front Assembly** and the **Case Rear Assembly** face down on a clean, stable work surface that will not scratch the front panel, connect the Spectrum Analyzer cables.
2. Connect the Spectrum Analyzer cable assembly (ribbon cable, item 14 in [Figure 7-5](#), and item 14 in [Figure 7-7](#)) to connector J5001 of the SPA board in the back case. For a visual reference with all cables connected, refer to [Figure 7-14 on page 7-26](#).
3. Snap the cable clamp closed on connector J5001.
4. Route the RF cables through the other cable clamp in the back case, and connect the following cables to the MMCX connections on the SPA PCB:
 - a. J4004 (item 7 in [Figure 7-14](#)) is for the 140 MHz IF connector. The other end is connected to J3203 on the Mother Board.
 - b. J6002 (item 8 in [Figure 7-14](#)) is for the 100 MHz In connector. The other end is connected to J2200 on the Mother Board.
 - c. J6000 (item 9 in [Figure 7-14](#)) is for the External Reference cable from the Ext. Ref. connector on the top connector panel (attached to the VNA Assembly).
 - d. J6001 (item 11 in [Figure 7-14](#)) is for the 10 MHz Ref Out connector on the top connector panel (attached to the VNA Assembly).
5. Carefully pivot the case back to close the case, guiding the cables and the top connector panel into case grooves.
6. Use a Phillips screwdriver to replace the four (4) Pan Head Phillips-head screws securing the two Case halves together. Torque these screws to 7.5 lbf · in (0.85 N · m).

Installing Battery:

Refer to [Section 5-4 “Battery Pack Removal and Replacement” on page 5-3](#).

7. Install the Battery.
8. Install the Battery Door.

Restarting the Instrument:

9. Restart the instrument.
10. Perform a function check to verify all repairs and part replacements.

7-18 Replacing SPA Module Assembly

ND72094 ND72095 ND72096

This replacement procedure provides instructions for replacing the Spectrum Analyzer (SPA) PCB Assemblies for all variants of the MS203xC VNA Masters. In general, the SPA PCB Assembly is removed as a complete unit and then exchanged for a replacement part.

Part Numbers

- ND72094 – SPA Module Assembly with N(f) connectors for MS2036C
 - For MS2036C instruments equipped with standard N(f) Test Ports
- ND72095 – SPA Module Assembly with N(f) connectors for MS2038C
 - For MS2038C instruments equipped with standard N(f) Test Ports
- ND72096 – SPA Module Assembly with K(f) connectors for MS2038C
 - For MS2038C instruments equipped with Option 11 K(f) Test Ports
- Additional parts are listed in [Section 1-8 “Replaceable Parts and Assemblies” on page 1-8](#).

Procedure

Opening the Case:

1. Open the case as described in [Section 7-17 “Opening the Instrument Case”](#) on page 7-24.

Removing Cables and Ext Trig Input BNC:

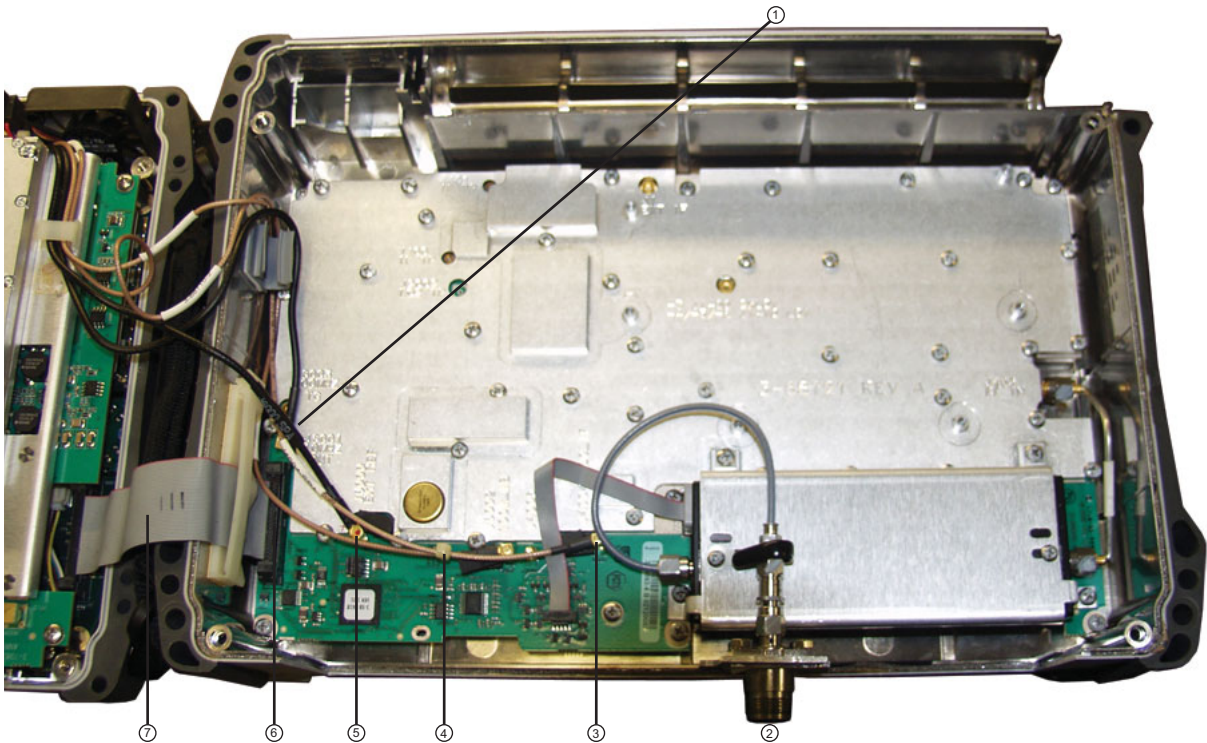

1. Connector J6001 (adjacent to ribbon cable J5001), 10 MHz Ref Out (cable connects to Ref Out 10 MHz SMA)
2. SPA RF In connector (Type N or Type K with Option 11)
3. Connector J4004, 140 MHz IF (cable connects to J3203 on Mother Board)
4. Connector J6002, 100 MHz MB (cable connects to J2200 on Mother Board)
5. Connector J6000, Ext Ref (cable connects to Ext Ref BNC on top connector panel)
6. Connector J5001, main connection from SPA PCB to Mother Board at J3000
7. Ribbon Cable, SPA PCB (J5001) to Mother Board (J3000)

Figure 7-15. SPA PCB Connections to Top Case Assembly

2. Use [Figure 7-15](#) to identify the cable connections for removal and replacement of the SPA PCB.
3. Press downward and then outward to open the cable clip (item 13 in [Figure 7-16](#)) that holds the 4 single cables from the Mother Board and VNA Assembly.
4. Use needle-nose pliers to remove the MCX RF coaxial cables from J6001, J6000, J6002, and J4004.
5. Pry open the cable clamp that holds the ribbon cable connector (J5001, item 11 in [Figure 7-16](#)), work the connector loose, and remove the cable.

This cable clamp is shown closed on the ribbon cable in [Figure 7-15](#) and is shown open and empty in [Figure 7-16](#). Note the end that is hinged and the shape of the open end.

Identifying SPA PCB Mounting Screws:

6. Using [Figure 7-16](#), identify the locations of the six (6) Phillips-head mounting screws that hold the SPA PCB in place.

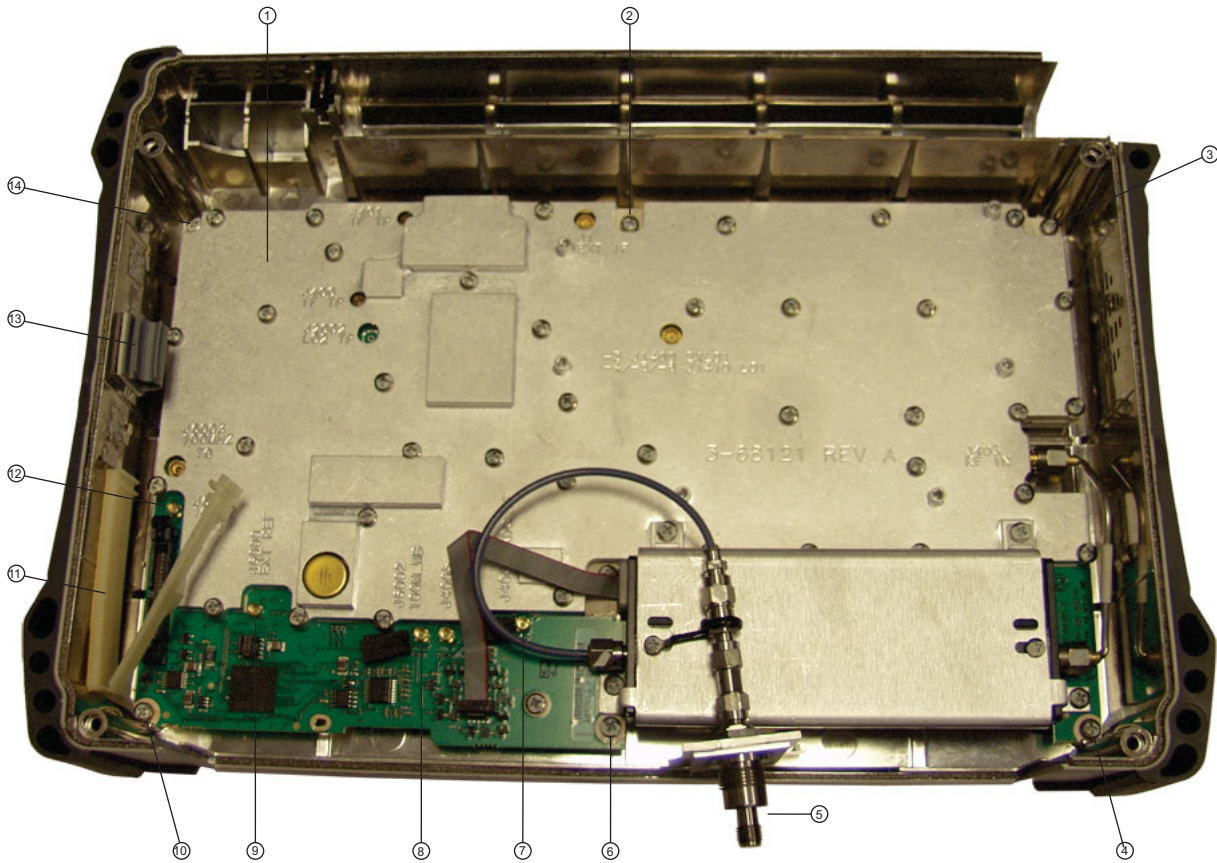

1. SPA PCB inside back case
2. PCB mounting screw (1 of 6)
3. PCB mounting screw (1 of 6)
4. PCB mounting screw (1 of 6)
5. SPA RF In connector (remains with SPA PCB)
6. PCB mounting screw (1 of 6)
7. J4004 MMCX connector for cable to MB J3203 (140 MHz IF)
8. J6002 MMCX connector for cable to MB J2200 (100 MHz)
9. J6000 MMCX connector for cable to External Reference BNC connector on instrument top connector panel
10. PCB mounting screw (1 of 6)
11. Ribbon cable clamp
12. J6001 MMCX connector for cable to 10 MHz Reference Out SMA connector on instrument top connector panel
13. Cable clip
14. PCB mounting screw (1 of 6)

Figure 7-16. SPA PCB Screw Locations

Removing the SPA PCB:

7. Using a Phillips-head screwdriver, remove the six (6) screws holding the SPA PCB in place.
8. Remove the SPA PCB from the case back and set it aside.

Installing the Replacement SPA PCB:

9. Position the replacement SPA PCB in the Case Bottom Assembly. Refer to [Figure 7-16](#) for general orientation. Using a Phillips-head screwdriver, tighten the six (6) screws that hold the SPA PCB in place. Torque the screws to 7.5 lbf·in (0.85 N·m).
10. Route the cables from the VNA Assembly top connector panel, the Ext Ref Input BNC connector and the Ref Out 10 MHz SMA connector, through the cable clip (item 13 in [Figure 7-16](#)).
11. Route the cables from the Mother Board (the 100 MHz cable from MB J2200 and the 140 MHz IF cable from MB J3203) through the cable clip along with the cables from the VNA Assembly top connector panel.
12. Close the cable clip around these 4 cables. It latches closed.
13. Using [Figure 7-15](#) and [Figure 7-16](#) to identify the cable connections, attach the 4 cables to the MMCX connectors on the SPA PCB:
 - a. Connect the 10 MHz Ref Out cable (SMA connector on VNA Assembly top connector panel) to SPA PCB J6001, which is directly adjacent to the ribbon cable connector, SPA PCB J5001.
 - b. Attach the Ext Ref cable (BNC connector on VNA Assembly top connector panel) to SPA PCB J6000.
 - c. Attach the Mother Board 100 MHz cable from MB J2200 to SPA PCB J6002.
 - d. Attach the Mother Board 140 MHz_IF cable from MB J3203 to SPA PCB J4004.
14. Attach the ribbon cable from Mother Board J3000 to connector SPA PCB J5001, and then close the cable clamp, item 11 in [Figure 7-16](#) (it snaps into place when locked closed).
15. The next step is to close the case. Verify that all cables are properly positioned.

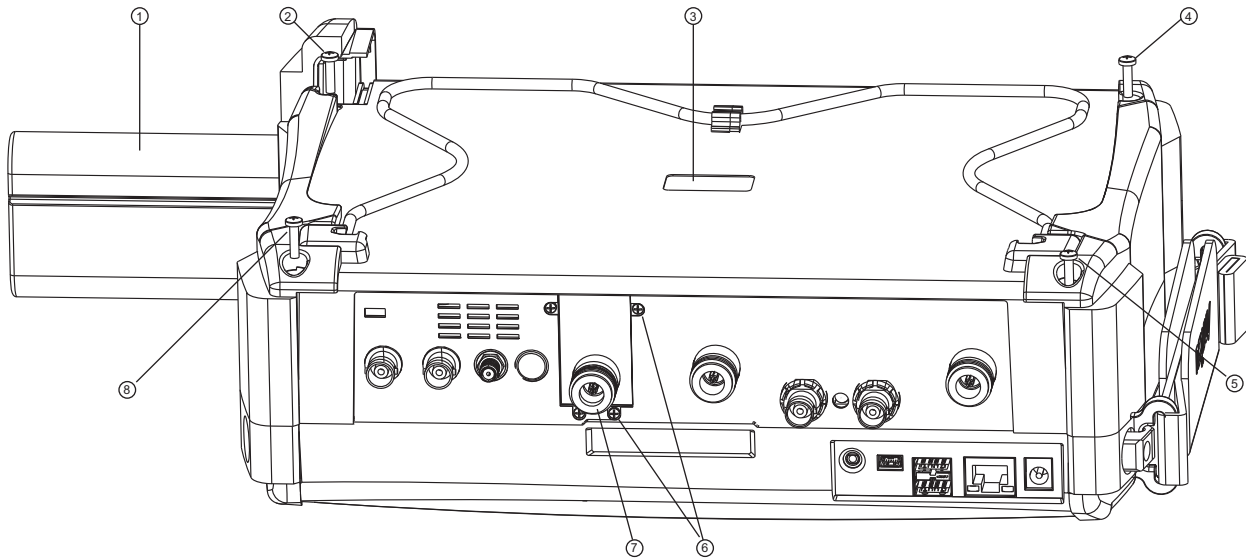
Replacing Case Rear Assembly:

1. Battery
2. Case Back screw (1 of 4)
3. Recess for serial number label (serial number of SPA PCB)
4. Case Back screw (1 of 4)
5. Case Back screw (1 of 4)
6. Screws (4) to hold SPA RF In connector mounting plate to top connector panel
7. SPA RF In port (supplied with SPA PCB)
8. Case Back screw (1 of 4)

Figure 7-17. Case for MS203xC

16. Replace the Case Bottom Assembly. Ensure that the SPA connector plate is properly engaged within the top connector panel. Ensure that the top connector panel is correctly centered in its mounting groove and that all cables are clear.

- a. Insert and tighten the four SPA connector plate mounting screws. Torque these screws to 4.0 lbf · in (0.45 N · m).
- b. Insert and tighten the four case mounting screws. Torque the screws to 7.5 lbf · in (0.85 N · m).

Installing Battery:

Refer to [Section 5-4 “Battery Pack Removal and Replacement”](#) on page 5-3.

17. Install the Battery.
18. Install the Battery Door.

Restarting the Instrument:

19. Restart the instrument.
20. Perform a function check to verify all repairs and part replacements.

7-19 Replacing VNA PCB Assembly

ND72091 ND72092 ND72093

This replacement procedure provides instructions for replacing the VNA PCB Assemblies for all variants of the MS203xC VNA Masters. In general, the VNA PCB Assembly is removed as a complete unit and then exchanged for a replacement part.

Part Numbers

- ND72091 – VNA PCB Assembly with N(f) connectors for MS2036C
For MS2036C instruments equipped with standard N(f) Test Ports
- ND72092 – VNA PCB Assembly with N(f) connectors for MS2038C
For MS2038C instruments equipped with standard N(f) Test Ports
- ND72093 – VNA PCB Assembly with K(f) connectors for MS2038C
For MS2038C instruments equipped with Option 11 K(f) Test Ports

Procedure

Opening the Case:

1. Open the case as described in [Section 7-17 “Opening the Instrument Case”](#) on page 7-24.

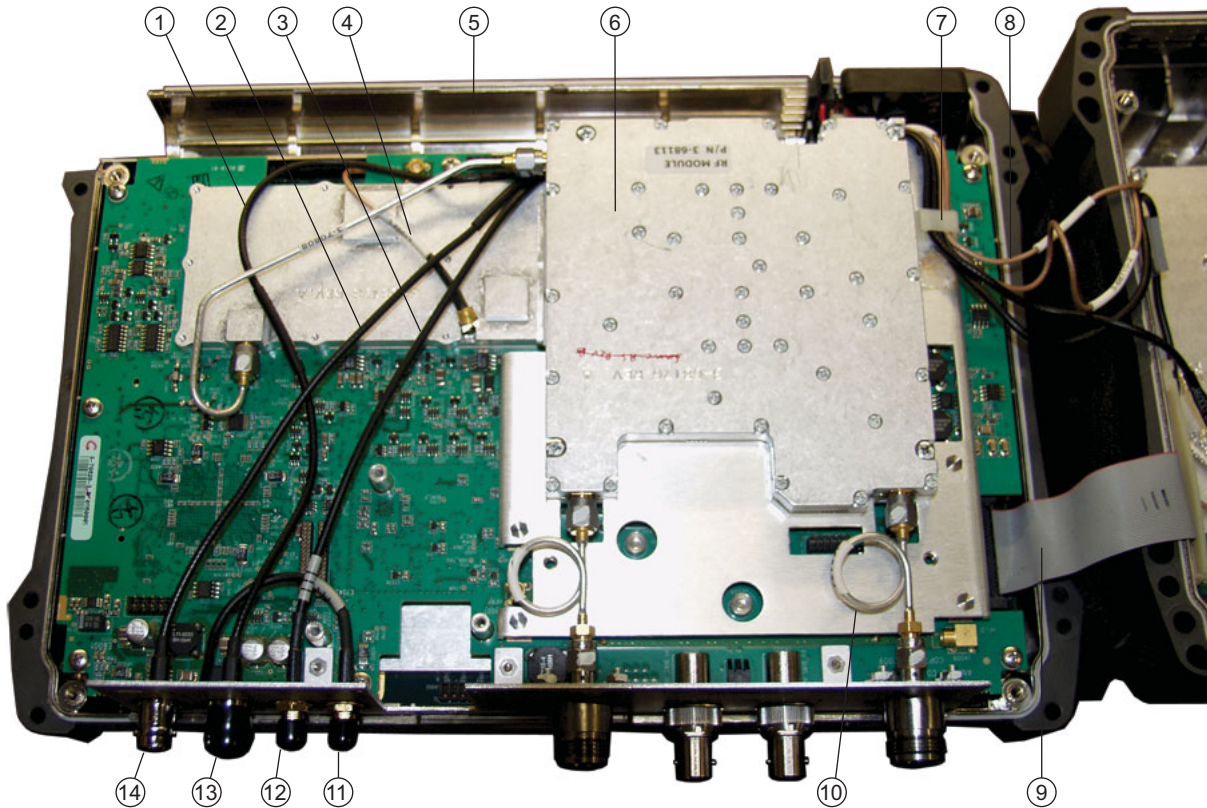

1. External Trigger cable (to MB J3202)
2. External Reference cable (to SPA J6000)
3. 10 MHz Reference Out cable (to SPA J6001)
4. 26 MHz VNA Reference cable (to MB J2201)
5. Battery Compartment
6. RF Module
7. Cable clip for 4 RF cables to SPA PCB
8. Cable bundle between VNA PCB Assembly and SPA PCB (4 cables)
9. Ribbon cable from MB J3000 to SPA J5001
10. Semi-Rigid cable to VNA Port
11. GPS Antenna SMA connector
12. 10 MHz REF OUT connector
13. EXT TRIG connector
14. EXT REF connector

Figure 7-18. VNA Assembly – Connected Within Front Case, MS2036C Shown

[Figure 7-18](#) shows model MS2036C. All steps to remove and replace the VNA PCB Assembly are the same for MS2036C and MS2038C instruments. In model MS2038C, the microwave module replaces the 2 semi-rigid cables shown as item [10](#). Refer also to the microwave module, item [15](#) in [Figure 7-7](#) on page 7-8.

Disconnecting GPS Antenna Cable:

2. If the GPS Receiver Module PCB (Option 31) is NOT installed, then skip ahead to [Step 3](#). If the GPS Receiver Module PCB is installed, then perform the following sub steps:
 - a. Use two 5/16 inch (≈ 8 mm) wrenches to disconnect the GPS Antenna SMA connector (item [11](#) in [Figure 7-18](#)) from the top connector panel.

- b. Remove the nut and lock washer and then remove the SMA connector from the top connector panel.
- c. Replace the lock washer and nut onto the SMA connector for safe keeping.
- d. Route the cable to the side, clearing the notch and the top Connector panel, so it is clear of the VNA PCB Assembly.
- e. Removing the GPS Antenna SMA connector also provides easier access to one of the VNA PCB Assembly mounting screws.

Removing Cables:

3. Cut the cable tie (if used) that holds the Ext Trig Input (item 1 in [Figure 7-18](#)) and Ext Ref Input (item 2 in [Figure 7-18](#)) coaxial cables to the RF Out semi-rigid coaxial cable.

Identifying VNA PCB Assembly Mounting Screws:

4. Using [Figure 7-19](#), identify the locations of the eight (8) Phillips-head mounting screws that hold the VNA Assembly PCB in place. [Figure 7-20](#) shows the 8 hexagonal standoffs on the Mother Board. The 8 VNA Assembly PCB screws attach to the 8 hexagonal standoffs in the Main PCB (Mother Board). The general locations of the 8 hexagonal standoffs are also visible in [Figure 7-4 on page 7-5](#) and [Figure 7-6 on page 7-7](#).

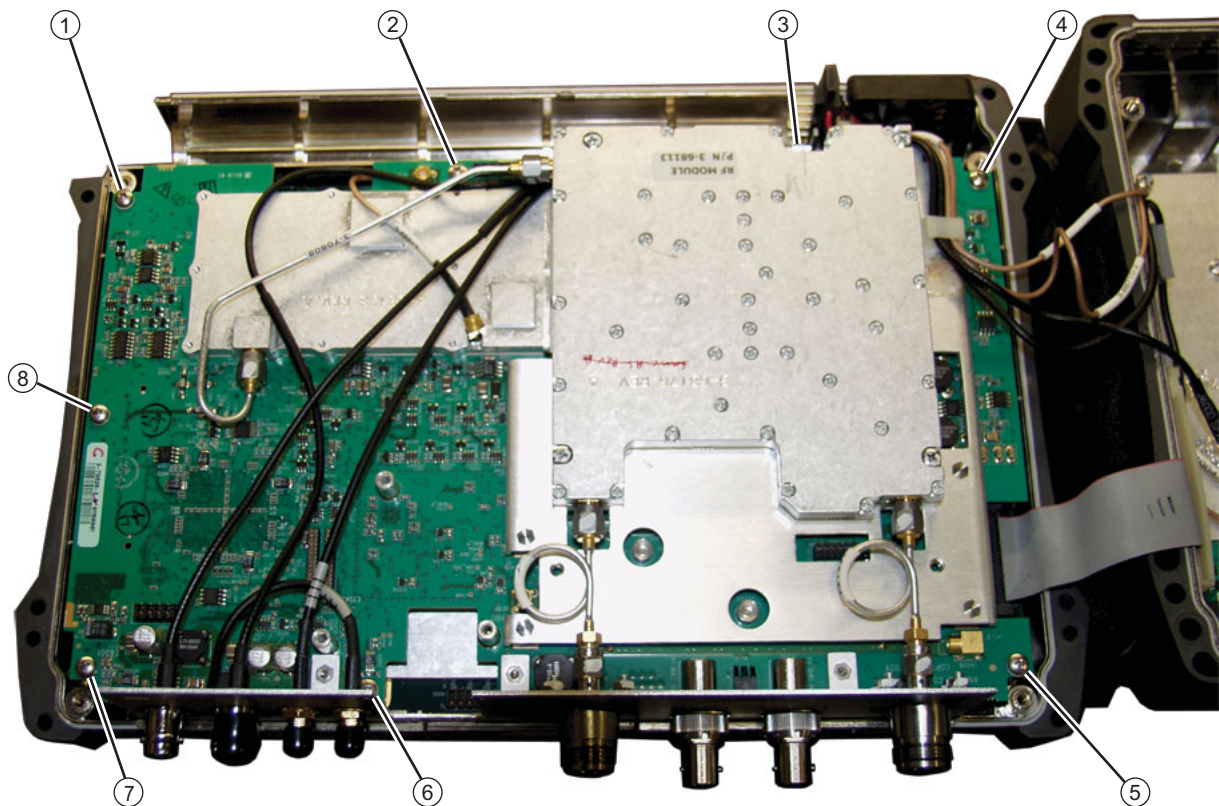

Figure 7-19. VNA PCB Assembly Screw Locations – MS2036C Shown

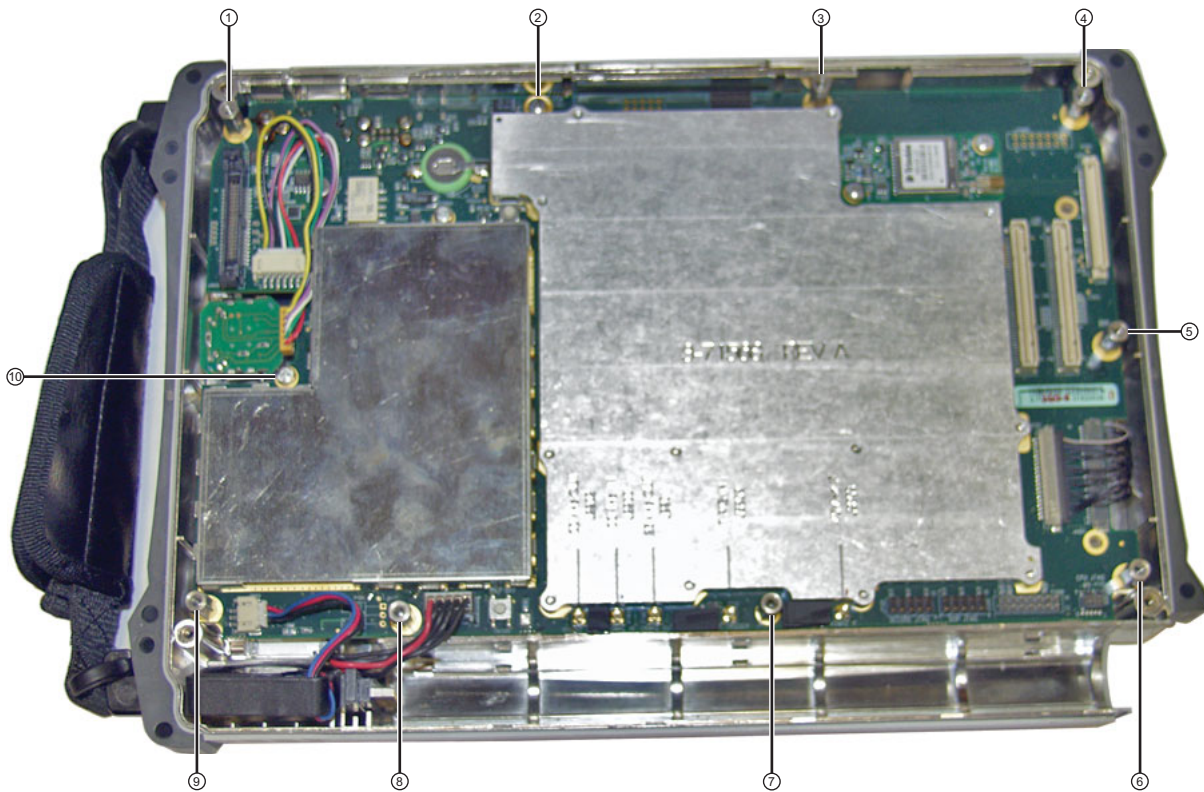
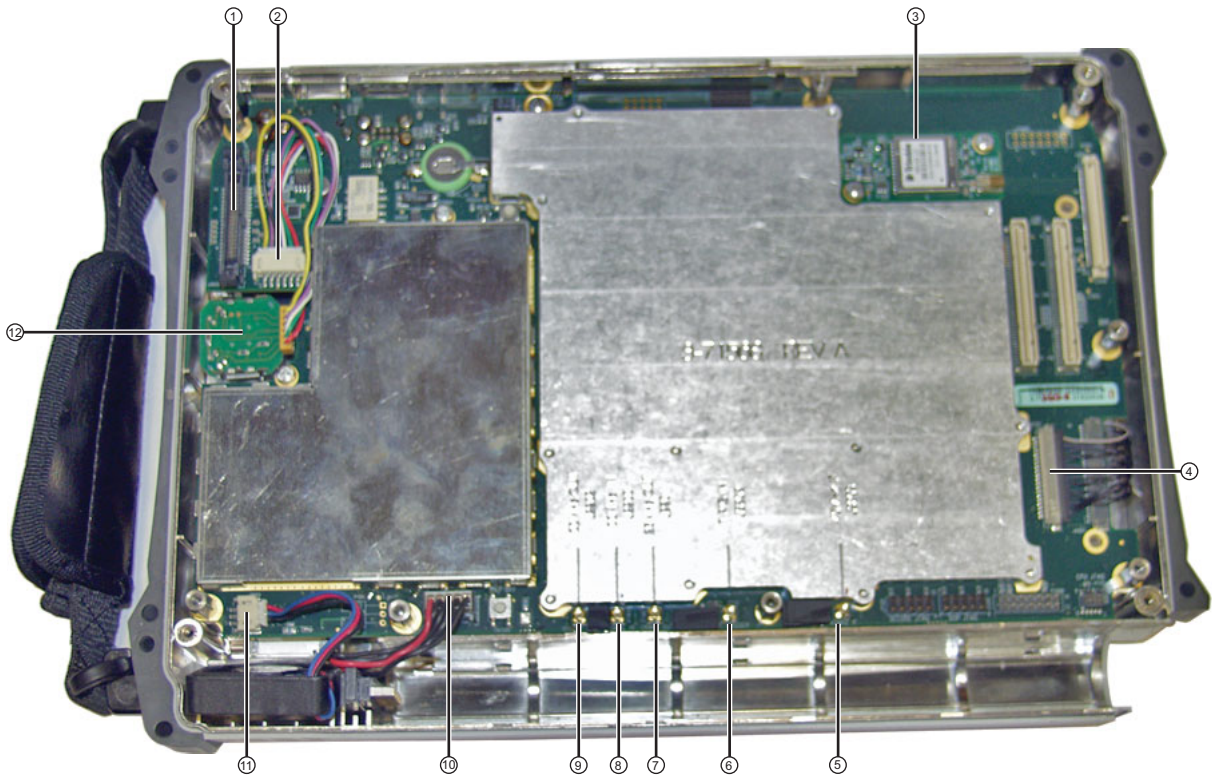

Figure 7-20. Main PCB (Mother Board) in Case – Standoffs and Screws

Removing the VNA PCB Assembly:

5. Using a Phillips-head screwdriver, remove the eight (8) screws holding the VNA PCB Assembly in place.
6. Two cables connect between the VNA PCB Assembly and the Mother Board. Refer to [Figure 7-21](#) for Mother Board connector locations.
 - a. The External Trigger In cable is attached to the Ext Trig In connector on the top connector panel and also to connector J3202 on the Mother Board.
 - b. The 26 MHz VNA reference cable is attached to the top shield of the VNA Module and also to connector J2201 on the Mother Board.
7. Two cables connect between the VNA PCB Assembly and the SPA PCB.
 - a. The External Reference In cable is attached to the Ext Ref In connector on the top connector panel and also to connector J6000 on the SPA PCB.
 - b. The 10 MHz Reference Out cable is attached to the Ref Out 10 MHz connector on the top connector panel and also to connector J6001 on the SPA PCB.
8. Lift the top edge of the VNA Assembly (with the attached top connector panel) and carefully move the VNA Assembly up and in the direction of the top of the case in order to expose the MCX cable connection on the Mother Board at J2201 and the MMCX cable connection on the Mother Board at J3202.



1. Connector J3000, 40-Pin, for ribbon cable to SPA PCB
2. Connector J5010, Twiddle connection for rotary encoder
3. GPS PCB (Option 31)
4. Connector J4202, for multi-conductor signal cable to LCD display
5. MMCX Connector J3203, 140 MHz IF (connects to SPA PCB at J4004)
6. MMCX Connector J3202, External Trigger (BNC connector on top connector panel)
7. MCX Connector J2201, 26 MHz Out (VNA reference, connects to J7002 on upper shield of VNA Module)
8. MMCX Connector J2200, 100 MHz In (connects to SPA PCB at J6002)
9. Connector J1003, Battery connection
10. Connector J1002, Fan connection
11. Rotary Encoder

Figure 7-21. Main PCB (Mother Board) in Case – Connections

Removing Coaxial Cables:

9. Using needle-nose pliers, remove the 4 attached coaxial cables from the Main PCB Assembly and the SPA PCB at the following locations. All 4 cables connect to locations on the VNA PCB Assembly. Leave the cables attached to the VNA PCB Assembly until you are ready for the replacement VNA Assembly.

a. From Mother Board (Main PCB Assembly):

- J2201 26 MHz Out – Cable connected to the top RF shield on the VNA Module. (MCX connectors)
- J3202 Trig In – Cable connected to the Ext Trig In BNC connector on the top connector panel of the VNA PCB Assembly and an MMCX connector on the Mother Board. Refer to [Figure 7-19 on page 7-35](#) for coaxial cable connections between the VNA PCB Assembly and the Main PCB Assembly.

b. From SPA PCB:

Cut the cable tie near the fan (if used) that holds the 4 RF cables that connect the case front to the case back.

- J6000 (Ext Ref) – Cable connected to the Ext Ref In BNC connector on the VNA PCB Assembly and an MMCX connector on the SPA PCB.
- J6001 (10 MHz Ref Out) – Cable connected to the Ref Out 10 MHz SMA connector on the top connector panel and an MMCX connector on the SPA PCB.

10. Remove the VNA PCB Assembly (with cables attached) and set it aside.

Preparing the Replacement VNA Assembly:

11. Prepare the replacement VNA PCB Assembly by transferring cables.

a. Using needle-nose pliers, remove the 26 MHz VNA Reference cable from the older VNA PCB Assembly. Attach one end to the MCX connector (J7002) on the top shield of the VNA Module.

b. Using the Tool T1451 socket, remove the castellated BNC dress nut from the Ext Trig In BNC connector from the older VNA PCB Assembly.

Attach the BNC connector in the top Connector panel of the replacement VNA Assembly. Use the Tool T1451 socket to tighten the BNC Connector Dress Nut. The torque specification is 7.5 lbf · in (0.85 N · m).

c. Using the Tool T1451 socket, remove the castellated BNC dress nut from the Ext Ref In BNC connector from the older VNA PCB Assembly.

Attach the BNC connector in the top connector panel of the replacement VNA Assembly. Use the Tool T1451 socket to tighten the BNC Connector Dress Nut. The torque specification is 7.5 lbf · in (0.85 N · m).

d. Use two 5/16 inch (\cong 8 mm) wrenches to disconnect the Ref Out 10 MHz SMA connector from the top connector panel of the older VNA PCB Assembly.

Use the two 5/16 inch (\sim 8 mm) wrenches to attach the SMA connector to the new connector panel. Torque the nut to 7.5 lbf · in (0.85 N · m).

12. If your instrument is equipped with the GPS Receiver Module (Option 31), then remove the hole plug for the GPS Antenna from the top connector panel.

Installing the Replacement VNA Assembly:

For cable routing and connections, refer to [Figure 7-19 on page 7-35](#) and [Figure 7-21 on page 7-37](#).

13. Position the replacement VNA Assembly on top of, and offset from, the Main PCB Assembly (Mother Board) such that the MCX and MMCX connectors along the lower edge of the Mother Board are exposed for easy cable attachment. Refer to [Figure 7-5 on page 7-6](#) and [Figure 7-7 on page 7-8](#) for general orientation.

14. Attach the 4 RF coaxial cables as follows:

a. To Mother Board (Main PCB Assembly):

- Attach the cable from the top RF shield on the VNA Module (MCX connector J7002) to Mother Board MCX connector J2201 26 MHz Out.
- Route the cable from the Ext Trig In BNC connector on the top connector panel through the notch to the Main PCB. Attach the cable to Mother Board MMCX connector J3202 Trig In. Refer to [Figure 7-19 on page 7-35](#) for coaxial cable connections between the VNA PCB Assembly and the Main PCB Assembly.

b. To SPA PCB:

- Route the cable from the Ext Ref In BNC connector on the top connector panel through the notch to the Main PCB and continue routing past the fan to the SPA PCB. Attach the cable to SPA PCB MMCX connector J6000 (Ext Ref).
- Route the cable from the Ref Out 10 MHz SMA connector on the top connector panel through the notch to the Main PCB and continue routing past the fan to the SPA PCB. Attach the cable to SPA PCB MMCX connector J6001 (10 MHz Out).

Replace the cable tie (part number 3-721-2) near the fan (if used) that holds the 4 RF cables that connect the case front to the case back.

Caution

All cables along the lower edge of the Mother Board and VNA PCB Assembly must be routed in such a manner that they will not be pinched between, or protrude between, the case halves of the upper battery compartment. If any cable protrudes into the battery compartment when the case is closed, then the cable may be damaged by pinching, or by the battery when it is inserted, or it may prevent battery insertion.

15. If the GPS Receiver Module PCB (Option 31) is not installed, then skip ahead to [Step 16](#). If the GPS Receiver Module PCB is installed, then perform the following sub steps:

- a. Route the GPS Antenna Cable with its SMA connector from the Main PCB, through the notch between the top connector panel and the VNA PCB, and into its position in the top Connector panel.
- b. Install the lock washer and then the nut, and tighten.
- c. Use two 5/16 inch (~8 mm) wrenches to attach the GPS Antenna SMA connector to the top connector panel. Torque the nut to 7.5 lbf · in (0.85 N · m).

16. Carefully position the VNA PCB Assembly over the Main PCB and the eight (8) hex standoffs.

17. After the connectors and the standoffs are correctly aligned, fasten the VNA PCB Assembly into place using eight (8) Phillips-head screws. Torque the screws to 7.5 lbf · in (0.85 N · m).

Replacing Case Rear Assembly:

18. Carefully fold the Case Bottom Assembly into place above the Case Top Assembly. Check the cables to ensure that they remain safely routed.

Caution

All cables along the lower edge of the Mother Board and VNA PCB Assembly must be routed in such a manner that they will not be pinched between, or protrude between, the case halves of the upper battery compartment. If any cable protrudes into the battery compartment when the case is closed, then the cable may be damaged by pinching, or by the battery when it is inserted, or it may prevent battery insertion.

19. Ensure that the SPA connector plate is properly engaged within the top connector panel. Insert and tighten the four plate mounting screws. Torque these screws to 4.0 lbf · in (0.45 N · m).

20. Carefully align the case assemblies and then insert and tighten the four case mounting screws. Torque the screws to 7.5 lbf · in (0.85 N · m).

Installing Battery:

Refer to [Section 5-4 “Battery Pack Removal and Replacement”](#) on page 5-3.

21. Install the Battery.
22. Install the Battery Door.

Restarting the Instrument:

23. Restart the instrument.
24. Perform a function check to verify all repairs and part replacements.

7-20 Replacing GPS Receiver Module (Option 31) – ND70320

This replacement procedure provides instructions for replacing the GPS Receiver Module mounted on the Main PCB Assembly for all variants of the MS203xC vector network analyzers. The basic procedure is to open the case, remove the VNA PCB Assembly, and then service the GPS Module.

Part Numbers

- ND70320 – GPS Receiver Module, Option 31
 - For MS2036C instruments equipped with Option 31 GPS Receiver
 - For MS2038C instruments equipped with Option 31 GPS Receiver
 - Includes SMA connector and cable to Receiver Module
 - Does not include GPS Antenna 2000-1528-R

Procedure

Opening the Case:

1. Open the case as described in [Section 7-17 “Opening the Instrument Case”](#).

Disconnecting GPS Antenna Cable:

2. Disconnect the GPS Antenna SMA connector from the top connector panel by performing the following sub steps:
 - a. Use two 5/16 inch (\cong 8 mm) end wrenches to disconnect the GPS Antenna SMA connector (item 11 in [Figure 7-18 on page 7-34](#)) from the top connector panel.
 - b. Pull off the nut and lock washer and remove the SMA connector from the top connector panel.
 - c. Replace the lock washer and nut onto the SMA connector for safe keeping.
 - d. Route the cable to the right side, clearing its notch and the top connector panel, so it is clear of the VNA PCB Assembly and the Case Front Assembly.

Removing Cables:

3. Cut the cable tie (if used) that holds the Ext Trig Input (item 1 in [Figure 7-18](#)) and Ext Ref Input (item 2 in [Figure 7-18](#)) coaxial cables to the RF Out semi-rigid coaxial cable.

Identifying VNA PCB Assembly Mounting Screws:

[Figure 7-22](#) shows model MS2036C. All steps to remove and replace the VNA PCB Assembly are the same for MS2036C and MS2038C instruments. In model MS2038C, the microwave module replaces the 2 semi-rigid cables. Refer also to the microwave module, item 15 in [Figure 7-7 on page 7-8](#).

4. Using [Figure 7-22](#), identify the locations of the eight (8) Phillips-head mounting screws that hold the VNA Assembly PCB in place. [Figure 7-20 on page 7-36](#) shows the 8 hexagonal standoffs on the Mother Board. The 8 VNA Assembly PCB screws attach to the 8 hexagonal standoffs in the Main PCB (Mother Board). The general locations of the 8 hexagonal standoffs are also visible in [Figure 7-4 on page 7-5](#) and [Figure 7-6 on page 7-7](#).

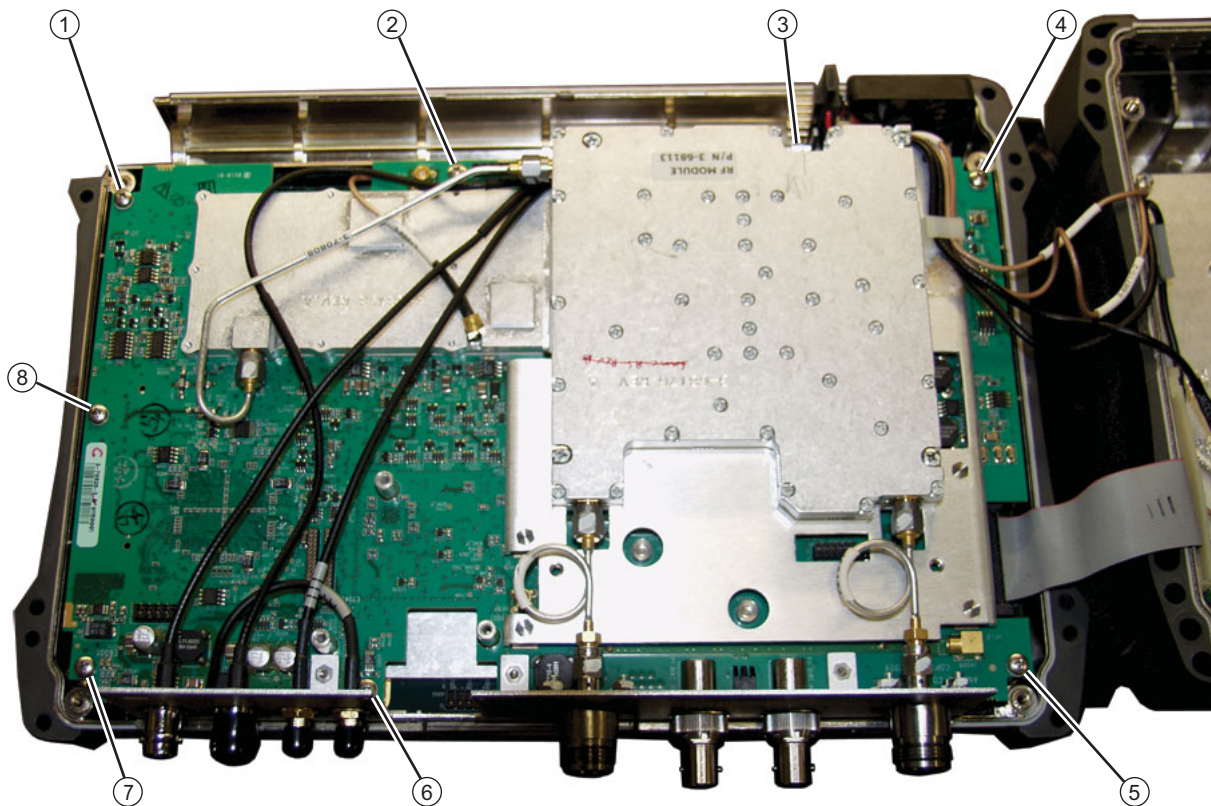

Figure 7-22. VNA PCB Assembly Screw Locations – MS2036C Shown

Removing the VNA PCB Assembly:

5. Using a Phillips-head screwdriver, remove the eight (8) screws holding the VNA PCB Assembly in place.
6. Two cables connect between the VNA PCB Assembly and the Mother Board. Refer to [Figure 7-21 on page 7-37](#) for Mother Board connector locations. They will be removed.
 - a. The External Trigger In cable is attached to the Ext Trig In connector on the top connector panel and also to connector J3202 on the Mother Board.
 - b. The 26 MHz VNA reference cable is attached to the top shield of the VNA Module and also to connector J2201 on the Mother Board.
7. Two cables connect between the VNA PCB Assembly and the SPA PCB. They will remain connected.
 - a. The External Reference In cable is attached to the Ext Ref In connector on the top connector panel and also to connector J6000 on the SPA PCB.
 - b. The 10 MHz Reference Out cable is attached to the Ref Out 10 MHz connector on the top connector panel and also to connector J6001 on the SPA PCB.
8. Lift the top edge of the VNA Assembly (with the attached connector panel) and carefully move the VNA Assembly up and in the direction of the top of the case in order to expose the MCX cable connection on the Mother Board at J2201 and the MMCX cable connection on the Mother Board at J3202.

Removing Coaxial Cables:

9. Using needle-nose pliers, remove the 2 attached coaxial cables from the Main PCB Assembly at the following locations. Leave the cables attached to the VNA PCB Assembly.
 - J2201 26 MHz Out – Cable connected to the top RF shield on the VNA Module. (MCX connectors)
 - J3202 Trig In – Cable connected to the Ext Trig In BNC connector on the top connector panel of the VNA PCB Assembly and an MMCX connector on the Mother Board. Refer to [Figure 7-19 on page 7-35](#) for coaxial cable connections between the VNA PCB Assembly and the Main PCB Assembly.
10. Carefully lift the VNA PCB Assembly and fold it over on top of the SPA PCB in the Case Bottom Assembly. Arrange the VNA PCB Assembly so that the remaining cables are not stressed.

Disconnecting the GPS Antenna Cable:

11. Use needle-nose pliers to remove the MCX RF coaxial connector from the GPS Receiver Module.

Removing the GPS Receiver Module:

12. Undo the two screws holding the GPS Receiver Module in place.
13. Gently pull the GPS Receiver Module straight up to disconnect its 14-pin header connector. The header pins should stay with the GPS Module.

Preparing and Installing the Replacement GPS Receiver Module:

14. Remove the replacement GPS Module from its packing material and prepare it for installation.
15. Position the replacement GPS Receiver Module so that it is lined up with its mounting holes and the 14-pin header connector and observe the following precautions:
 - a. Carefully position the GPB Receiver Module PCB over its mounting standoffs.
 - b. Use extreme care so as to not bend any of the header pins.
 - c. Be careful to not offset the header pins by one row.
 - d. Make sure that the header pins are loosely but correctly positioned before proceeding.
 - e. When perfectly aligned, press on each side of the header strip to mate the two connectors.
16. Insert and tighten the two Phillips-head mounting screws. Torque these screws to 7.5 lbf · in (0.85 N · m).
Note that these screws are shorter than the screws that are used to hold the VNA PCB Assembly in place.

Installing the GPS Antenna Cable and SMA Connector:

17. Snap the GPS Antenna Cable MCX connector into place on the GPS Receiver Module. Position the Antenna Cable off the right side of the Case.

Installing the VNA PCB Assembly:

18. Position the replacement VNA PCB Assembly above the top case and the Mother Board with the lower edge of the Mother Board and the connectors exposed.
19. Attach the 2 RF coaxial cables to the Mother Board (Main PCB Assembly) as follows:
 - Attach the cable from the top RF shield on the VNA Module (MCX connector J7002) to Mother Board MCX connector J2201 26 MHz Out.
 - Route the cable from the Ext Trig In BNC connector on the top connector panel through the notch to the Main PCB. Attach the cable to Mother Board MMCX connector J3202 Trig In. Refer to [Figure 7-22 on page 7-42](#) for coaxial cable connections between the VNA PCB Assembly and the Main PCB Assembly.
20. Replace the cable tie (part number 3-721-2) near the fan (if removed) that holds the 4 RF cables that connect the case front to the case back.

21. Position the VNA PCB Assembly as accurately as possible over the Main PCB Assembly observing the following:

- The fan and other cables on the left side of the Case are clear of the hex standoffs and the Case edge.
- The GPS Antenna Cable is correctly routed between the top connector panel and the PCB and is located in its notch.
- The coaxial cables between the two PCBs are on the OUTSIDE of the hex standoffs and also clear of the Case edge.

Caution

All cables along the lower edge of the Mother Board and VNA PCB Assembly must be routed in such a manner that they will not be pinched between, or protrude between, the case halves of the upper battery compartment. If any cable protrudes into the battery compartment when the case is closed, then the cable may be damaged by pinching, or by the battery when it is inserted, or it may prevent battery insertion.

22. Make sure that the top connector panel is correctly positioned in its mounting groove.

23. Fasten the VNA PCB Assembly into place using eight (8) Phillips-head screws.
Torque these screws to 7.5 lbf · in (0.85 N · m).

24. Route the GPS Antenna Cable with SMA connector in the slot between the top connector panel and the PCB, until the cable is correctly positioned in the PCB notch cutout.

25. Install the SMA connector into the top connector panel, add the lock washer, and finally the nut.

26. Use two 5/16 inch (~8 mm) wrenches to attach the GPS Antenna SMA connector to the top connector panel. Torque the nut to 7.5 lbf · in (0.85 N · m).

Replacing Case Rear Assembly and Battery:

27. Carefully fold the Case Bottom Assembly into place above the Case Top Assembly, making sure that the top connector panel is correctly centered in its mounting groove in the case back and that all cables are clear. Check the cables to ensure that they remain safely routed.

Caution

All cables along the lower edge of the Mother Board and VNA PCB Assembly must be routed in such a manner that they will not be pinched between, or protrude between, the case halves of the upper battery compartment. If any cable protrudes into the battery compartment when the case is closed, then the cable may be damaged by pinching, or by the battery when it is inserted, or it may prevent battery insertion.

28. Ensure that the SPA connector plate is properly engaged within the top connector panel. Insert and tighten the four plate mounting screws. Torque these screws to 4.0 lbf · in (0.45 N · m).

29. Carefully align the case assemblies and then insert and tighten the four case mounting screws. Torque the screws to 7.5 lbf · in (0.85 N · m).

Installing Battery:

Refer to [Section 5-4 “Battery Pack Removal and Replacement” on page 5-3](#).

30. Install the Battery.

31. Install the Battery Door.

Restarting the Instrument:

32. Restart the instrument.

33. Perform a function check to verify all repairs and part replacements.

7-21 Replacing Rotary Encoder – 3-410-101

Replacing the Rotary Encoder involves removing the Rotary Knob, and then opening the case and partially removing the VNA PCB Assembly. If the GPS Receiver Module (Option 31) is installed, then the GPS Antenna must be disconnected. After the VNA PCB Assembly is “folded” out of the way, the Rotary Encoder mounting hardware can be loosened from the Front Panel, and its cable detached from the Main PCB Assembly. The Main PCB Assembly and Keypad Bezel need not be removed to replace the Rotary Encoder.

Part Numbers

- 3-410-101 – Rotary Encoder
 - For MS2036C and MS2038C instruments
 - Includes the connection cable to the Main PCB Assembly, for connector J5010
 - Does not include the Rotary Knob – 3-61360-2

Procedure

Removing the Rotary Knob:

1. Use a flat-blade screwdriver and piece of rubber (as a fulcrum) to remove the Rotary Knob.
2. Use a 7/16 inch (\cong 12 mm) nut driver to remove the nut, lock washer, and flat washer that hold the Encoder in place. Save the nut, star washer, and flat washer for use on the replacement Rotary Encoder.

Opening the Case:

3. Open the case as described in [Section 7-17 “Opening the Instrument Case” on page 7-24](#)

Disconnecting GPS Antenna Cable (if Option 31 is Installed):

4. If Option 31 is not installed, then skip to [Step 5](#). If Option 31 is installed, then disconnect the GPS Antenna SMA connector from the top connector panel by performing the following sub steps:
 - a. Use two 5/16 inch (\cong 8 mm) end wrenches to disconnect the GPS Antenna SMA connector (item 11 in [Figure 7-18 on page 7-34](#)) from the top connector panel.
 - b. Pull off the nut and lock washer and remove the SMA connector from the top connector panel.
 - c. Replace the lock washer and nut onto the SMA connector for safe keeping.
 - d. Route the cable to the right side, clearing its notch and the top connector panel, so it is clear of the VNA PCB Assembly and the Case Front Assembly.

Removing Cables:

5. Cut the cable tie (if used) that holds the Ext Trig Input (item 1 in [Figure 7-18](#)) and Ext Ref Input (item 2 in [Figure 7-18](#)) coaxial cables to the RF Out semi-rigid coaxial cable.

Identifying VNA PCB Assembly Mounting Screws:

6. Using [Figure 7-23](#), identify the locations of the eight (8) Phillips-head mounting screws that hold the VNA Assembly PCB in place. [Figure 7-20 on page 7-36](#) shows the 8 hexagonal standoffs on the Mother Board. The 8 VNA Assembly PCB screws attach to the 8 hexagonal standoffs in the Main PCB (Mother Board). The general locations of the 8 hexagonal standoffs are also visible in [Figure 7-4 on page 7-5](#) and [Figure 7-6 on page 7-7](#).

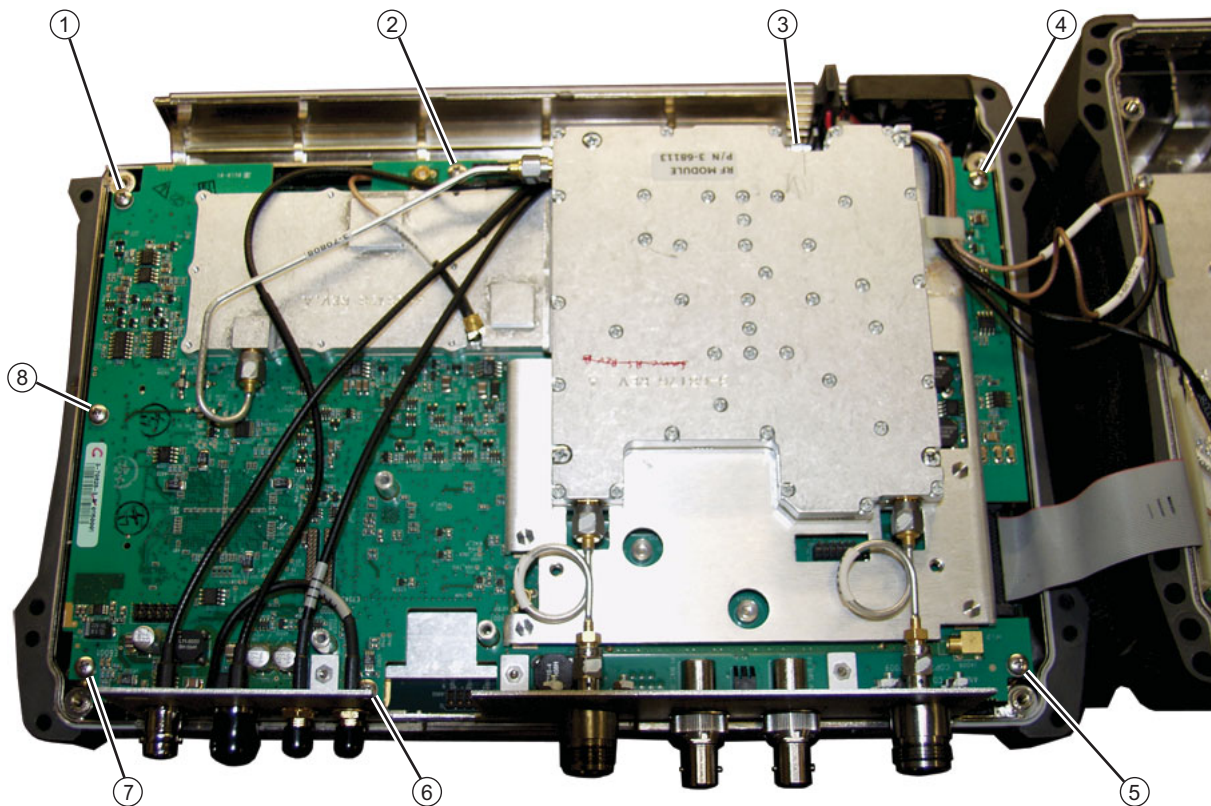

Figure 7-23. VNA PCB Assembly Screw Locations – MS2036C Shown

Removing the VNA PCB Assembly:

[Figure 7-23](#) shows model MS2036C. All steps to remove and replace the VNA PCB Assembly are the same for MS2036C and MS2038C instruments. In model MS2038C, the microwave module replaces the 2 semi-rigid cables. Refer also to the microwave module, item 15 in [Figure 7-7 on page 7-8](#).

7. Using a Phillips-head screwdriver, remove the eight (8) screws holding the VNA PCB Assembly in place.
8. Two cables connect between the VNA PCB Assembly and the Mother Board. Refer to [Figure 7-21 on page 7-37](#) for Mother Board connector locations. They will be removed.
 - a. The External Trigger In cable is attached to the Ext Trig In connector on the top connector panel and also to connector J3202 on the Mother Board.
 - b. The 26 MHz VNA reference cable is attached to the top shield of the VNA Module and also to connector J2201 on the Mother Board.
9. Two cables connect between the VNA PCB Assembly and the SPA PCB. They will remain connected.
 - a. The External Reference In cable is attached to the Ext Ref In connector on the top connector panel and also to connector J6000 on the SPA PCB.
 - b. The 10 MHz Reference Out cable is attached to the Ref Out 10 MHz connector on the top connector panel and also to connector J6001 on the SPA PCB.
10. Lift the top edge of the VNA Assembly (with the attached top connector panel) and carefully move the VNA Assembly up and in the direction of the top of the case in order to expose the MCX cable connection on the Mother Board at J2201 and the MMCX cable connection on the Mother Board at J3202.

Removing Coaxial Cables:

11. Using needle-nose pliers, remove the 2 attached coaxial cables from the Main PCB Assembly at the following locations. Leave the cables attached to the VNA PCB Assembly.
 - J2201 26 MHz Out – Cable connected to the top RF shield on the VNA Module. (MCX connectors)
 - J3202 Trig In – Cable connected to the Ext Trig In BNC connector on the top connector panel of the VNA PCB Assembly and an MMCX connector on the Mother Board. Refer to [Figure 7-19 on page 7-35](#) for coaxial cable connections between the VNA PCB Assembly and the Main PCB Assembly.
12. Carefully lift the VNA PCB Assembly and fold it over on top of the SPA PCB in the Case Bottom Assembly. Arrange the VNA PCB Assembly so that the remaining cables are not stressed.

Removing the Rotary Encoder:

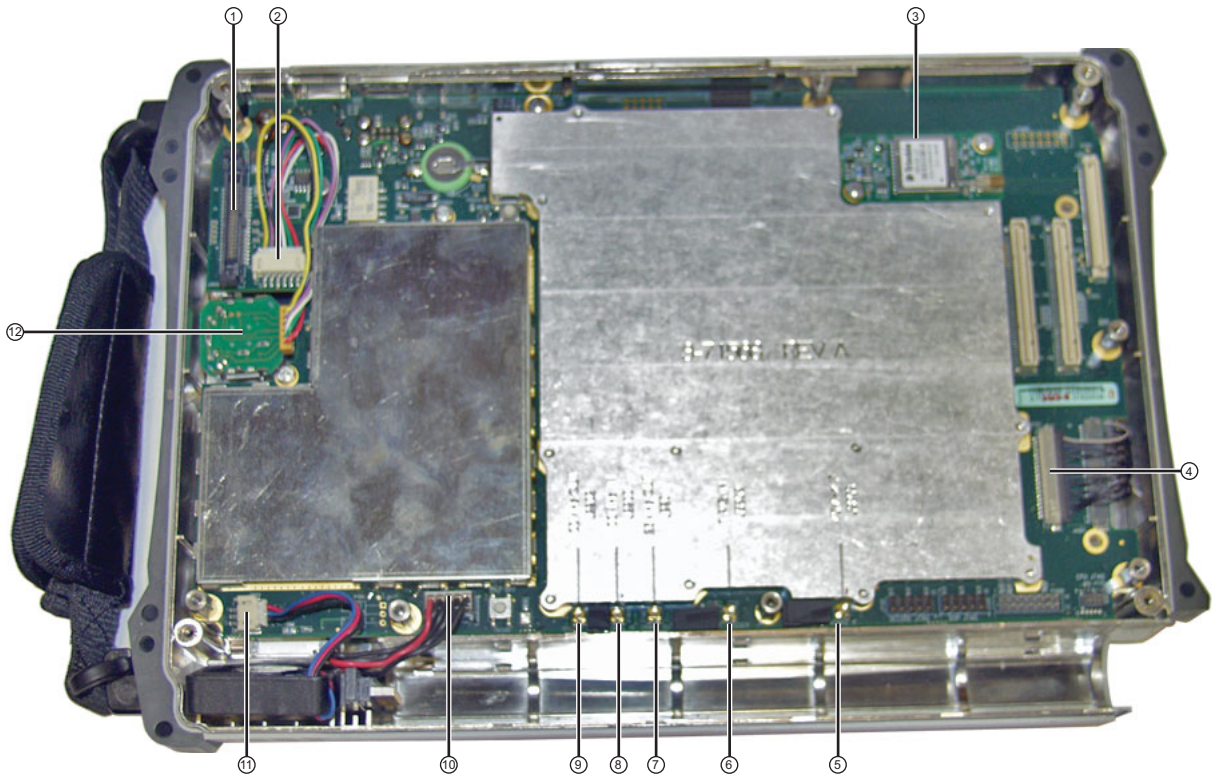

1. Connector MB J3000 to SPA PCB via ribbon cable
2. Connector MB J5010, for rotary encoder
3. GPS Receiver Module PCB (Option 31)
4. Connector MB J4202, for signal cable to LCD display
5. MMCX Connector MB J3203, 140 MHz IF
6. MMCX Connector MB J3202, Ext Trigger
7. MCX Connector MB J2201, 26 MHz Out (VNA Ref)
8. MMCX Connector MB J2200, 100 MHz In
9. MMCX Connector MB J2202 100 MHz Out
10. Connector MB J1003, Battery
11. Connector MB J1002, Fan
12. Rotary Encoder

Figure 7-24. Mother Board (Main PCB) Connections

13. On the inside of the case, disconnect the Rotary Encoder cable from the Main PCB Assembly at connector J5010. The cable end enters J5010 from the top, and is removed by prying it away from the Rotary Encoder.
14. Withdraw the Rotary Encoder and its attached cable from the case and set it aside.

Installing Replacement Rotary Encoder:

15. Position the **replacement Rotary Encoder** in the case with the cable extending towards the center of the Case.
16. Attach the Rotary Encoder cable to the Main PCB Assembly at J5010. The cable connector goes into the PCB connector on the side away from the Encoder with the connector ridges up. Coil up excess cable on top of the encoder PCB.
17. From the front panel, add in sequence: the flat washer, lock (star) washer, and nut. Tighten the nut to hold in place by using a 7/16 inch ($\cong 12$ mm) nut driver. Torque the nut to 8 lbf ·in (0.9 N ·m).
18. From the front panel, press on the Rotary Knob.

Installing the VNA PCB Assembly:

19. Position the VNA PCB Assembly above the top case and the Mother Board with the lower edge of the Mother Board and the MMCX connectors exposed.
20. Attach the 2 RF coaxial cables to the Mother Board (Main PCB Assembly) as follows:
 - Attach the cable from the top RF shield on the VNA Module (MCX connector J7002) to Mother Board MCX connector J2201 26 MHz Out.
 - Route the cable from the Ext Trig In BNC connector on the top connector panel through the notch to the Main PCB. Attach the cable to Mother Board MMCX connector J3202 Trig In. Refer to [Figure 7-22 on page 7-42](#) for coaxial cable connections between the VNA PCB Assembly and the Main PCB Assembly.
21. Replace the cable tie near the fan (part number 3-721-2, if removed) that holds the 4 RF cables that connect the case front to the case back.
22. Position the VNA PCB Assembly as accurately as possible over the Main PCB Assembly while observing the following:
 - The fan and other cables on the left side of the Case are clear of the hex standoffs and the Case edge.
 - The GPS Antenna Cable is correctly routed between the top connector panel and the PCB and is located in its notch.
 - The coaxial cables between the two PCBs are on the OUTSIDE of the hex standoffs and also clear of the Case edge.

Caution	All cables along the lower edge of the Mother Board and VNA PCB Assembly must be routed in such a manner that they will not be pinched between, or protrude between, the case halves of the upper battery compartment. If any cable protrudes into the battery compartment when the case is closed, then the cable may be damaged by pinching, or by the battery when it is inserted, or it may prevent battery insertion.
----------------	--

23. Make sure that the top connector panel is correctly positioned in its mounting grove in the Case Front.
24. Fasten the VNA PCB Assembly into place using eight (8) Phillips-head screws. Torque these screws to 7.5 lbf ·in (0.85 N ·m).
25. Route the GPS Antenna Cable with SMA connector in the slot between the top connector panel and the PCB, until the cable is correctly positioned in the PCB notch cutout.
26. Install the SMA connector into the top connector panel, add the lock washer, and finally the nut.
27. Use two 5/16 inch (~ 8 mm) wrenches to attach the GPS Antenna SMA connector to the top connector panel. Torque the nut to 7.5 lbf ·in (0.85 N ·m).

Replacing Case Rear Assembly and Battery:

28. Carefully fold the Case Bottom Assembly into place above the Case Top Assembly, making sure that the top connector panel is correctly centered in its mounting groove in the case back and that all cables are clear. Check the cables to ensure that they remain safely routed.

Caution	All cables along the lower edge of the Mother Board and VNA PCB Assembly must be routed in such a manner that they will not be pinched between, or protrude between, the case halves of the upper battery compartment. If any cable protrudes into the battery compartment when the case is closed, then the cable may be damaged by pinching, or by the battery when it is inserted, or it may prevent battery insertion.
----------------	--

29. Ensure that the SPA connector plate is properly engaged within the top connector panel. Insert and tighten the four plate mounting screws. Torque these screws to 4.0 lbf ·in (0.45 N ·m).
30. Carefully align the case assemblies and then insert and tighten the four case mounting screws. Torque the screws to 7.5 lbf ·in (0.85 N ·m).

Installing Battery:

Refer to [Section 5-4 “Battery Pack Removal and Replacement”](#) on page 5-3.

31. Install the Battery.
32. Install the Battery Door.

Restarting the Instrument:

33. Restart the instrument.
34. Perform a function check to verify all repairs and part replacements.

7-22 Removing Main PCB Assembly

This procedure covers removing the Main PCB Assembly from the MS2036C and MS2038C instruments by removing the VNA PCB Assembly, the GPS Receiver Module (if installed), and finally the Main PCB Assembly (Mother Board). After the Main PCB Assembly is removed, separate replacement procedures are available:

- [Section 7-23 – Replacing Main PCB Assembly – ND72086, ND72087 on page 7-56](#)
- [Section 7-24 – Replacing LCD Display – 3-15-154 on page 7-59](#)
- [Section 7-25 – Replacing Clear Plastic LCD Protector – 3-61368 on page 7-61](#)

After the required replacement units are installed, the final procedure describes how to reinstall the Main PCB Assembly, GPS Receiver Module, VNA PCB Assembly, and finally to close the case:

- [Section 7-26 – Installing Main PCB and Reassembling Instrument on page 7-62](#)

Procedure

1. Place the instrument face up on a protected work surface oriented with the top Connector Panel away from you.
2. Remove the Battery Door and the Battery.

Opening the Case and Remove the VNA PCB:

1. Open the case as described in [Section 7-17 “Opening the Instrument Case”](#) on page 7-24.

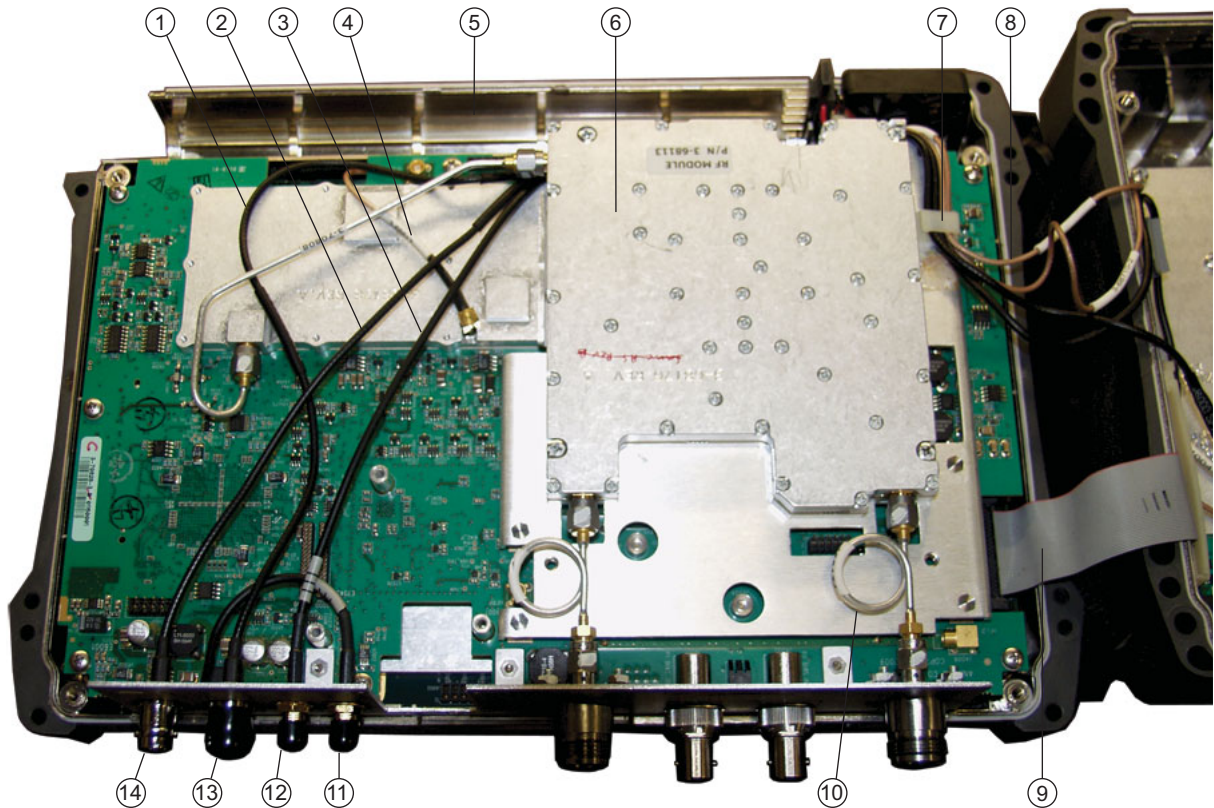

1. External Trigger cable (to MB J3202)
2. External Reference cable (to SPA J6000)
3. 10 MHz Reference Out cable (to SPA J6001)
4. 26 MHz VNA Reference cable (to MB J2201)
5. Battery Compartment
6. RF Module
7. Cable bundle between VNA PCB Assembly and SPA PCB (4 cables)
8. Ribbon cable from MB J3000 to SPA J5001
9. Semi-Rigid cable to VNA Port
10. GPS connector
11. 10 MHz REF OUT connector
12. EXT TRIG connector
13. EXT REF connector

Figure 7-25. VNA Assembly – Connected Within Front Case, MS2036C Shown

Disconnecting GPS Antenna Cable:

2. If the GPS Receiver Module PCB (Option 31) is NOT installed, then skip ahead to [Step 3](#). If the GPS Receiver Module PCB is installed, then perform the following sub steps:
 - a. Use two 5/16 inch (\cong 8 mm) wrenches to disconnect the GPS Antenna SMA connector (item 11 in [Figure 7-18](#)) from the top connector panel.

- b. Remove the nut and lock washer and then remove the SMA connector from the top connector panel.
- c. Replace the lock washer and nut onto the SMA connector for safe keeping.
- d. Route the cable to the side, clearing the notch and the top connector panel, so it is clear of the VNA PCB Assembly.
- e. Removing the GPS Antenna SMA connector also provides easier access to one of the VNA PCB Assembly mounting screws.

Removing Cables:

3. Cut the cable tie (if used) that holds the Ext Trig Input (item 1 in [Figure 7-18](#)) and Ext Ref Input (item 2 in [Figure 7-18](#)) coaxial cables to the RF Out semi-rigid coaxial cable.

Identifying VNA PCB Assembly Mounting Screws:

[Figure 7-26](#) shows model MS2036C. All steps to remove and replace the VNA PCB Assembly are the same for MS2036C and MS2038C instruments. In model MS2038C, the microwave module replaces the 2 semi-rigid cables. Refer also to the microwave module, item 15 in [Figure 7-7 on page 7-8](#).

4. Using [Figure 7-26](#), identify the locations of the eight (8) Phillips-head mounting screws that hold the VNA Assembly PCB in place. [Figure 7-27 on page 7-53](#) shows the 8 hexagonal standoffs on the Mother Board. The 8 VNA Assembly PCB screws attach to the 8 hexagonal standoffs in the Main PCB (Mother Board). The general locations of the 8 hexagonal standoffs are also visible in [Figure 7-4 on page 7-5](#) and [Figure 7-6 on page 7-7](#).

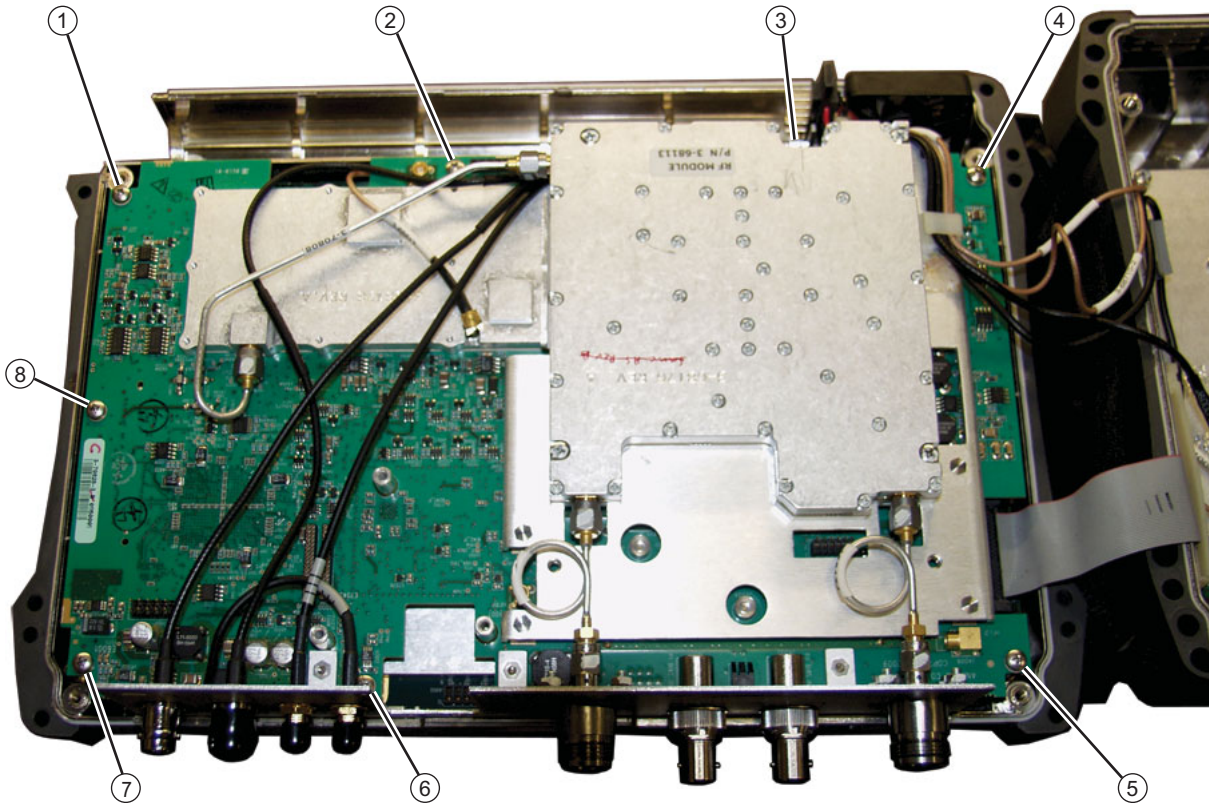

Figure 7-26. VNA PCB Assembly Screw Locations – MS2036C Shown

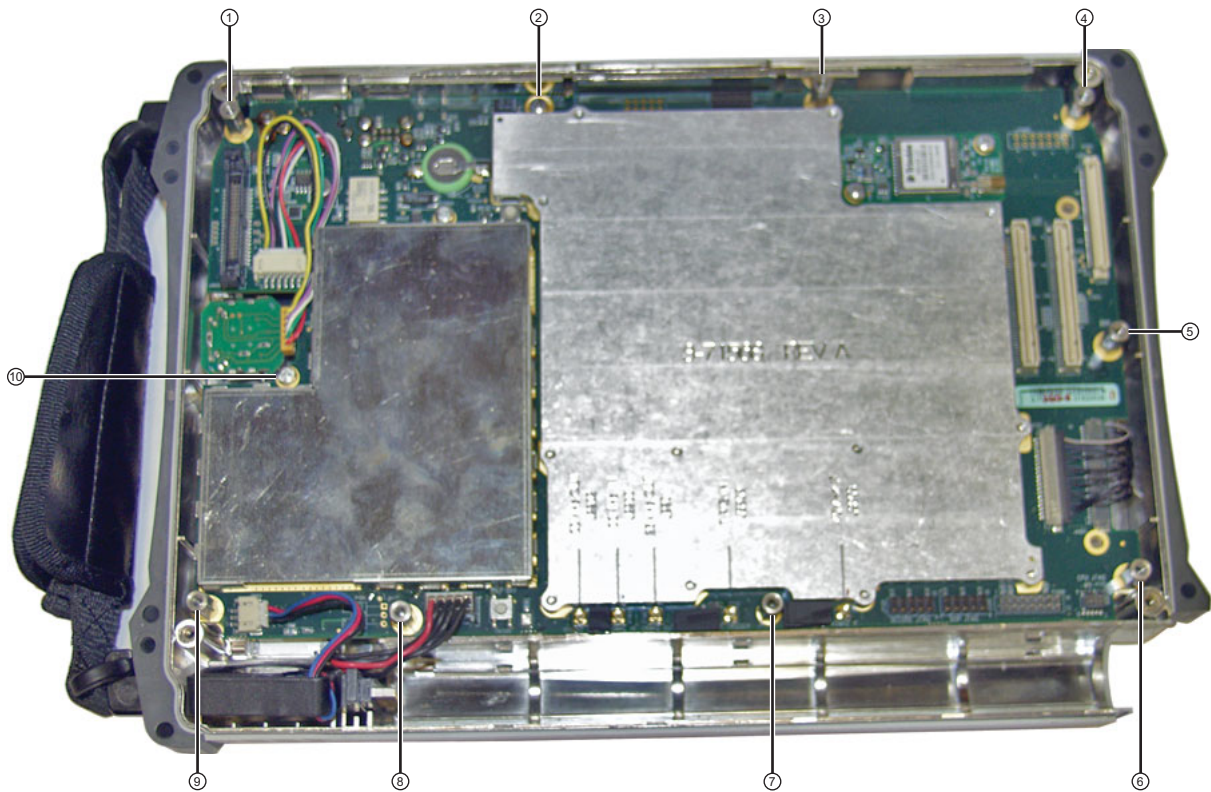
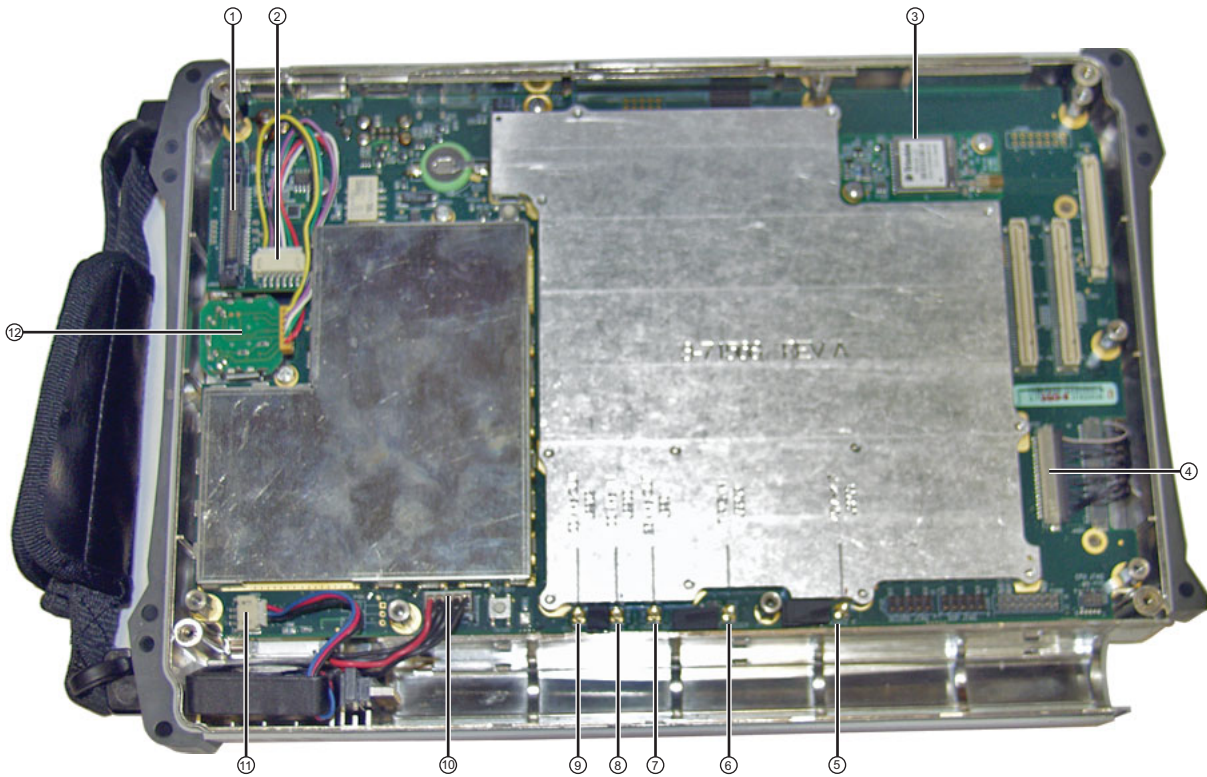

Figure 7-27. Main PCB (Mother Board) in Case – Standoffs and Screws

Removing the VNA PCB Assembly:

5. Using a Phillips-head screwdriver, remove the eight (8) screws holding the VNA PCB Assembly in place.
6. Two cables connect between the VNA PCB Assembly and the Mother Board. Refer to [Figure 7-21](#) for Mother Board connector locations.
 - a. The External Trigger In cable is attached to the Ext Trig In connector on the top connector panel and also to connector J3202 on the Mother Board.
 - b. The 26 MHz VNA reference cable is attached to the top shield of the VNA Module and also to connector J2201 on the Mother Board.
7. Two cables connect between the VNA PCB Assembly and the SPA PCB. These cables were disconnected from the SPA PCB while you were performing the steps in [Section 7-17 “Opening the Instrument Case” on page 7-24](#). Leave the cables attached to the VNA PCB Assembly. They will be reattached to the SPA PCB later. Their locations are:
 - a. The External Reference In cable attaches to the Ext Ref In connector on the top connector panel and also to connector J6000 on the SPA PCB.
 - b. The 10 MHz Reference Out cable attaches to the Ref Out 10 MHz connector on the top connector panel and also to connector J6001 on the SPA PCB.
8. Lift the top edge of the VNA Assembly (with the attached connector panel) and carefully move the VNA Assembly up and in the direction of the top of the case in order to expose the MCX cable connection on the Mother Board at J2201 and the MMCX cable connection on the Mother Board at J3202.



1. Connector J3000, 40-Pin, for ribbon cable to SPA PCB
2. Connector J5010, Twiddle connection for rotary encoder
3. GPS PCB (Option 31)
4. Connector J4202, for multi-conductor signal cable to LCD display
5. MMCX Connector J3203, 140 MHz IF (connects to SPA PCB at J4004)
6. MMCX Connector J3202, External Trigger (BNC connector on top connector panel)
7. MCX Connector J2201, 26 MHz Out (VNA reference, connects to J7002 on upper shield of VNA Module)
8. MMCX Connector J2200, 100 MHz In (connects to SPA PCB at J6002)
9. Connector J1003, Battery connection
10. Connector J1002, Fan connection
11. Rotary Encoder

Figure 7-28. Main PCB (Mother Board) in Case – Connections

Removing Coaxial Cables:

9. Using needle-nose pliers, remove the 2 attached coaxial cables from the Main PCB Assembly. Leave the cables attached to the VNA PCB Assembly until you are ready for the replacement Main PCB Assembly.

From Mother Board (Main PCB Assembly), disconnect:

- J2201 26 MHz Out – Cable connected to the top RF shield on the VNA Module. (MCX connectors)
- J3202 Trig In – Cable connected to the Ext Trig In BNC connector on the top connector panel of the VNA PCB Assembly and an MMCX connector on the Mother Board. Refer to [Figure 7-28 on page 7-54](#) for coaxial cable connections between the VNA PCB Assembly and the Main PCB Assembly.

10. Remove the VNA PCB Assembly (with the RF cables attached) and set it aside.

Removing Main PCB Assembly:

11. Remove the eight (8) hex standoffs and two (2) Pan Head screws holding the Main PCB Assembly to the Case Front Assembly. Refer to [Figure 7-27 on page 7-53](#) for hex standoff and screw locations.
12. Near the side of the case, disconnect the cable from the Rotary Encoder PCB at connector J5010 (item 2 in [Figure 7-28](#)). The Rotary Encoder stays mounted in the Case Front Assembly.
13. Near the bottom of the case, disconnect the following cables from the Main PCB and fold them over the case edge clear of the PCB:
 - The Battery Cable from connector J1003 ((item 9 in [Figure 7-28](#)))
 - The Fan Cable from connector J1002 ((item 10 in [Figure 7-28](#)))
14. At this point, proceed with any of the following replacement procedures described in the following sections:
 - [Section 7-23 – Replacing Main PCB Assembly – ND72086, ND72087 on page 7-56](#)
 - [Section 7-24 – Replacing LCD Display – 3-15-154 on page 7-59](#)
 - [Section 7-25 – Replacing Clear Plastic LCD Protector – 3-61368 on page 7-61](#)
15. After the required replacement procedures are complete, reassemble the instrument by using the procedure in [Section 7-26 – Installing Main PCB and Reassembling Instrument on page 7-62](#)

Installing Battery:

Refer to [Section 5-4 “Battery Pack Removal and Replacement” on page 5-3](#).

16. Install the Battery.
17. Install the Battery Door.

Restarting the Instrument:

18. Restart the instrument.
19. Perform a function check to verify all repairs and part replacements.

7-23 Replacing Main PCB Assembly – ND72086, ND72087

This procedure is written with the assumption that the Main PCB Assembly has been removed from the instrument as described in [Section 7-22 – Removing Main PCB Assembly on page 7-50](#) and that the Main PCB Assembly is to be replaced. The basic replacement procedure is the same for MS2036C and MS2038C instruments.

If an assembly that is mounted on the Main PCB is to be replaced, then skip to the appropriate section:

- [Section 7-24 – Replacing LCD Display – 3-15-154 on page 7-59](#)
- [Section 7-25 – Replacing Clear Plastic LCD Protector – 3-61368 on page 7-61](#)

Part Numbers

- ND72086 – Main PCB Assembly for MS2036C instruments
 - VNA PCB Assembly not included
 - LCD Display not included
 - GPS Receiver Module PCB not included
- ND72087 – Main PCB Assembly for MS2038C instruments
 - VNA PCB Assembly not included
 - LCD Display not included
 - GPS Receiver Module PCB not included

Procedure

1. The Main PCB Assembly has already been removed from the Case Front Assembly.

Removing the LCD Display:

2. Disconnect the LCD multi-conductor signal cable from connector J4202 on the Main PCB Assembly (refer to [Figure 7-29](#)). The cable is permanently attached to the LCD Panel.
3. Disconnect the LCD backlight cable from connector P6000 on the Main PCB Assembly (refer to item [3](#) [Figure 7-30](#)). The cable is permanently attached to the LCD Panel.

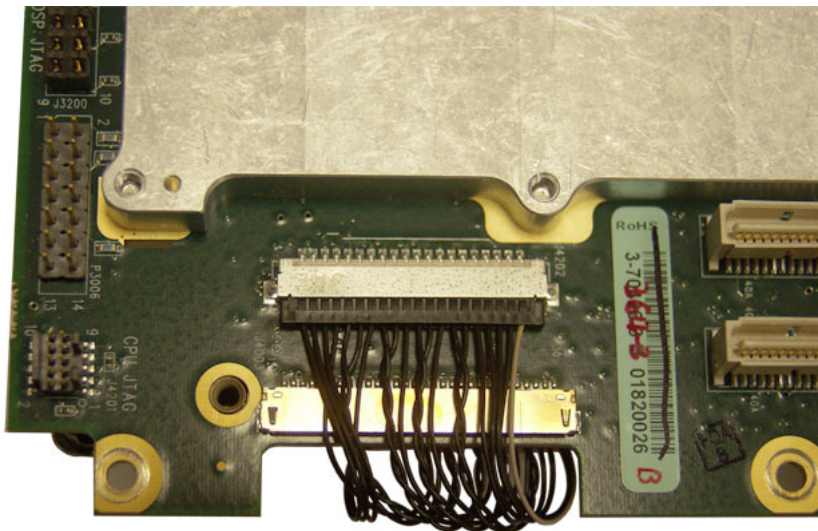
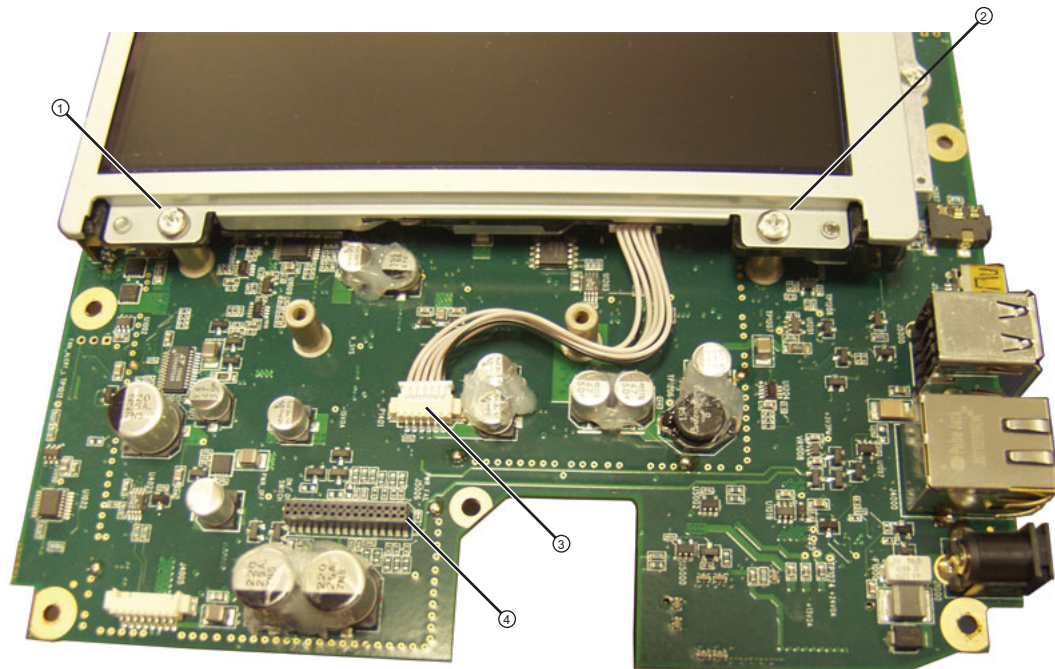

Figure 7-29. Connector J4202, for LCD Signal Cable to Mother Board



1. Phillips-head mounting screws holding the LCD Assembly to the Main PCB (only 2 of 4 screws shown)
2. Phillips-head mounting screws holding the LCD Assembly to the Main PCB (only 2 of 4 screws shown)
3. LCD Backlight Cable connection to P6000 connector on Main PCB Assembly
4. Main PCB Assembly connector J5006 to Main Keyboard Assembly

Figure 7-30. LCD Cable, Mounting Screws, and Backlight Cable

4. Undo the four (4) Phillips-head screws holding the LCD Display in place and set the LCD aside.

Removing the GPS Receiver Module:

5. If the GPS Receiver Module PCB Option 31 is not installed, or if it has already been removed, then skip ahead to the next step. If it is installed and has not been removed, then perform the following sub steps:
 - a. Turn over the Main PCB (Mother Board).
 - a. Undo the two screws holding the GPS Receiver Module in place.
 - b. Gently pull the GPS Receiver Module straight up to disconnect its 14-pin header connector. The header connector should stay with the GPS Receiver Module.

Preparing the Replacement Main PCB:

Prepare the replacement Main PCB by installing the LCD Display and, if equipped, the GPS Receiver Module as described in the following steps.

6. Install the LCD Panel Assembly:
 - a. Fasten the LCD assembly in place with four (4) pan head screws. Torque these screws to 7.5 lbf · in (0.85 N · m).
 - b. Attach the LCD backlight cable to Mother Board connector P6000 ((refer to item 3 Figure 7-29)).
 - c. Attach the LCD Signal cable to the J4202 connector socket on the Main PCB (refer to Figure 7-29).
7. Before installing the reassembled Main PCB Assembly, clean the Clear Plastic LCD Protection Plate by using compressed air and LCD compatible wipes.
8. The Main PCB Assembly is now ready to reassemble in the Case Front Assembly. Continue with the reassembly process in [Section 7-26 – Installing Main PCB and Reassembling Instrument on page 7-62](#).

Installing Battery:

Refer to [Section 5-4 “Battery Pack Removal and Replacement”](#) on page 5-3.

9. Install the Battery.
10. Install the Battery Door.

Restarting the Instrument:

11. Restart the instrument.
12. Perform a function check to verify all repairs and part replacements.

7-24 Replacing LCD Display – 3-15-154

This procedure is written with the assumption that the Main PCB Assembly has been removed from the instrument as described in [Section 7-22](#) and that the LCD Display must be replaced. The replacement procedure is the same for MS2036C and MS2038C instruments.

Part Numbers

- 3-15-154 – LCD Display for MS2036C and MS2038C instruments

Procedure

1. Open the instrument case and remove the Main PCB Assembly.
 - Refer to [Section 7-22 “Removing Main PCB Assembly”](#) on page 7-50

Removing the LCD Display:

2. Disconnect the LCD multi-conductor signal cable from connector J4202 on the Main PCB Assembly (refer to [Figure 7-31](#)). The cable is permanently attached to the LCD Panel.
3. Disconnect the LCD backlight cable from connector P6000 on the Main PCB Assembly (refer to item 3 [Figure 7-32](#)). The cable is permanently attached to the LCD Panel.

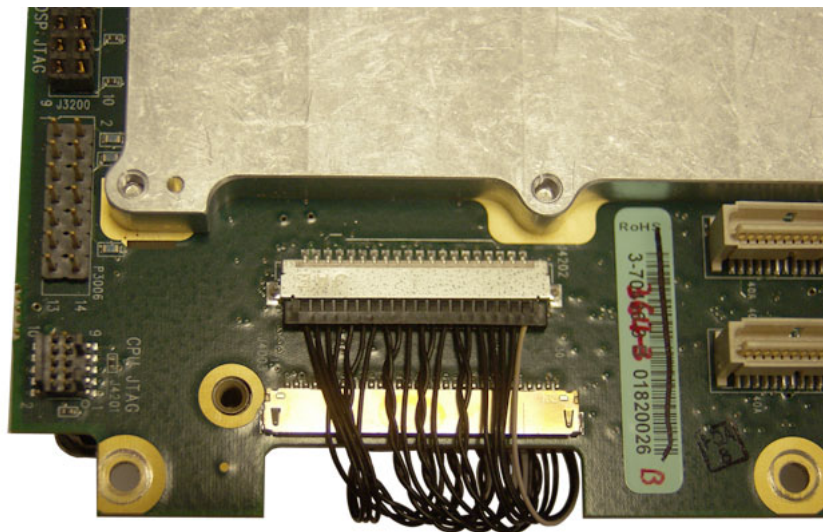
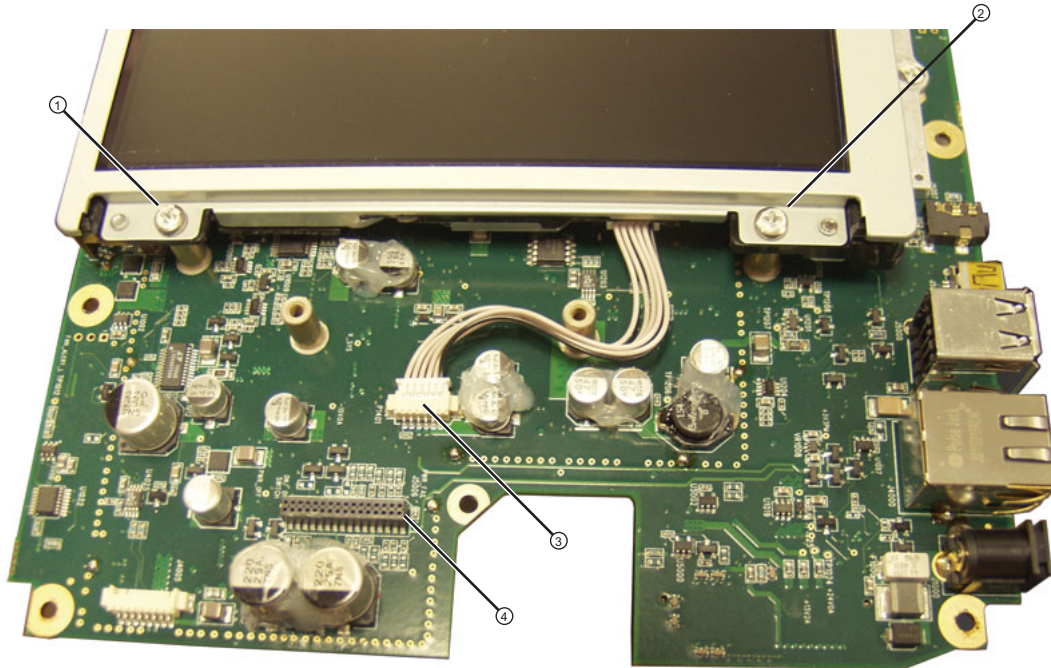

Figure 7-31. Connector J4202, for LCD Signal Cable to Mother Board



1. Phillips-head mounting screws holding the LCD Assembly to the Main PCB (only 2 of 4 screws shown)
2. Phillips-head mounting screws holding the LCD Assembly to the Main PCB (only 2 of 4 screws shown)
3. LCD Backlight Cable connection to P6000 connector on Main PCB Assembly
4. Main PCB Assembly connector J5006 to Main Keyboard Assembly

Figure 7-32. LCD Cable, Mounting Screws, and Backlight Cable

4. Undo the four (4) Phillips-head screws holding the LCD Display in place and set the LCD aside (refer to [Figure 7-32](#)).
5. Clean the replacement LCD Screen by using compressed air and LCD compatible wipes.
6. Install the LCD Panel Assembly:
 - a. Fasten the LCD assembly in place with the 4 pan head screws. Torque these screws to 7.5 lbf · in (0.85 N · m).
 - b. Attach the LCD backlight cable to Mother Board connector P6000 ((refer to item 3 [Figure 7-32](#))).
 - c. Attach the LCD Signal cable to the J4202 connector socket on the Main PCB (refer to [Figure 7-31](#)).
7. If no further replacements are pending, then install the Main PCB and reassemble the instrument by following the procedure in [Section 7-26 “Installing Main PCB and Reassembling Instrument”](#) on page 7-62.

Installing Battery:

Refer to [Section 5-4 “Battery Pack Removal and Replacement”](#) on page 5-3.

8. Install the Battery.
9. Install the Battery Door.

Restarting the Instrument:

10. Restart the instrument.
11. Perform a function check to verify all repairs and part replacements.

7-25 Replacing Clear Plastic LCD Protector – 3-61368

This procedure is written with the assumption that the Main PCB Assembly has been removed from the instrument as described in [Section 7-22](#) and that the Clear Plastic LCD Protector must be replaced. The replacement procedure is the same for MS2036C and MS2038C instruments.

Part Numbers

- 3-61368 – Clear Plastic LCD Protector for MS2036C and MS2038C instruments

Procedure

1. Open the instrument case and remove the Main PCB Assembly.
Refer to [Section 7-22 “Removing Main PCB Assembly”](#) on page 7-50
2. Remove the Clear Plastic LCD Protector by pushing it from the front.
3. The protector has an inset edge which goes into the hole and faces out. The protector “lip” is set towards the inside of the case.
4. The outside of the Protector has a protective “skin” that should be left in place until the instrument is reassembled.
5. Clean the inside of the Protector by using compressed air and LCD compatible wipes.
6. Avoiding fingerprints, install the protector into the Case Front opening. The protector “lip” goes towards the inside of the case.
7. If no further unit replacements are required, then install the Main PCB and reassemble the instrument by following the procedure in [Section 7-26 “Installing Main PCB and Reassembling Instrument”](#) on page 7-62.

Installing Battery:

Refer to [Section 5-4 “Battery Pack Removal and Replacement”](#) on page 5-3.

8. Install the Battery.
9. Install the Battery Door.

Restarting the Instrument:

10. Restart the instrument.
11. Perform a function check to verify all repairs and part replacements.

7-26 Installing Main PCB and Reassembling Instrument

This procedure is written with the assumption that any required assemblies have been replaced and installed on the Main PCB Assembly.

Procedure

Installing the Main PCB Components:

1. If not already done, then install the LCD Display on the Main PCB as described in [Section 7-24 “Replacing LCD Display – 3-15-154” on page 7-59.](#)

Installing the Clear Plastic LCD Protector:

2. If required, but not already done, then install the LCD Protector as described in [Section 7-25 “Replacing Clear Plastic LCD Protector – 3-61368” on page 7-61.](#)
3. If not already done, then clean the inner surface of the Protector with compressed air and LCD compatible wipes, leaving the outer protective film in place, and place the Protector into the Case Front, with the “lip” towards the inside of the case.

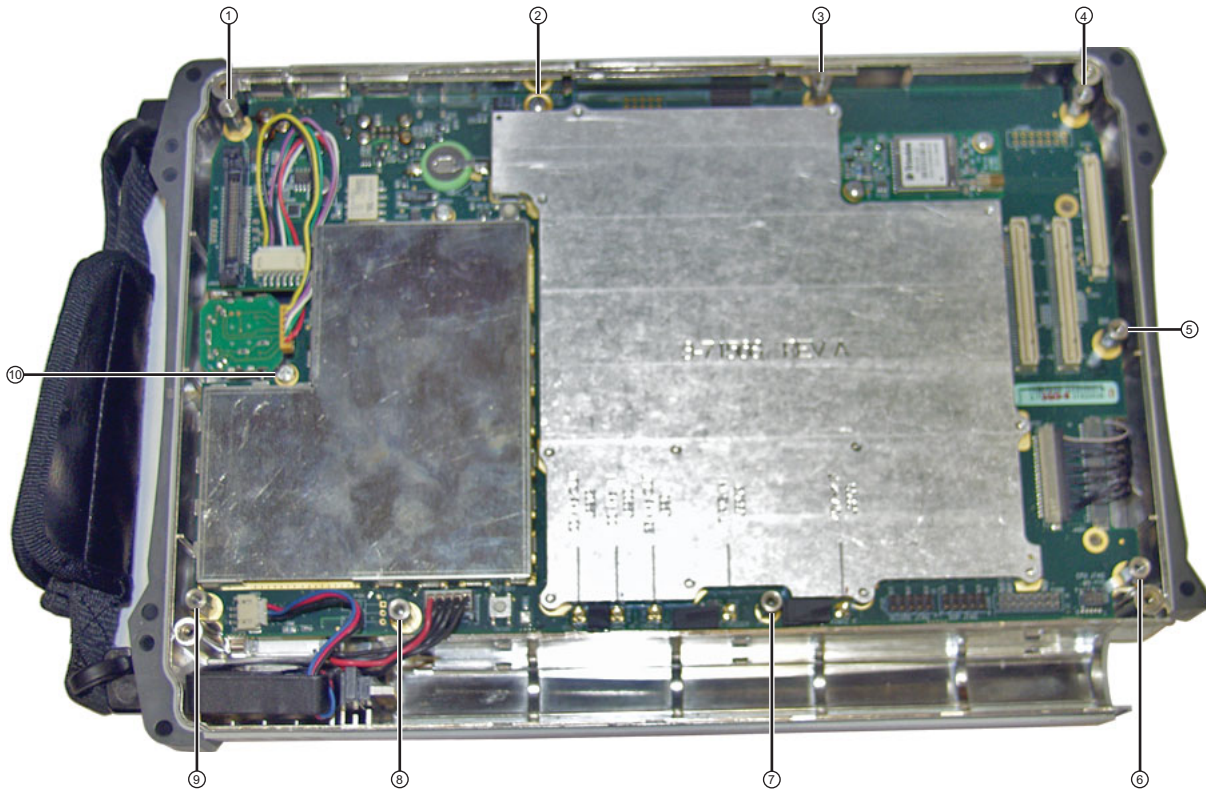

Figure 7-33. Main PCB (Mother Board) in Case – Standoffs and Screws

Installing the Main PCB:

4. The connectors (External Power Input, LAN, USB, and Headset Jack) of the Main PCB will protrude into the Case Front. Holding the standoff (item 7 in [Figure 7-33](#)), insert that connector edge of the Main PCB first into the case.
 - a. Rest the edge of the Main PCB on the screw pads and apply a slight pressure to the Main PCB toward the top of the case by pressing on a shield. If the Main Keypad is not yet installed in the Case Front, then skip to [Step 5](#). If the Main Keypad is already installed in the Case Front, then continue with the following sub steps:

The purpose of the pressure is to ensure that the connectors are properly engaged into the case top. This helps to ensure alignment of the critical connection with the Main Keypad Assembly (J1 and J5006).

- b. Lower the Main PCB while maintaining the slight upward pressure (via the shield) and by holding the standoff and pivoting the Main PCB against the top of the case until connector J1 of the Main Keypad Assembly is engaged in connector J5006 of the Main PCB (for J5006, refer to item 4 in [Figure 7-32 on page 7-60](#), and for J1, refer to item 1 in [Figure 7-34 on page 7-63](#)). Press down gently on the Main PCB shield to fully seat this connector.
- c. Take care to ensure that you do not damage the connection between the Main PCB and the Main Keypad Assembly.

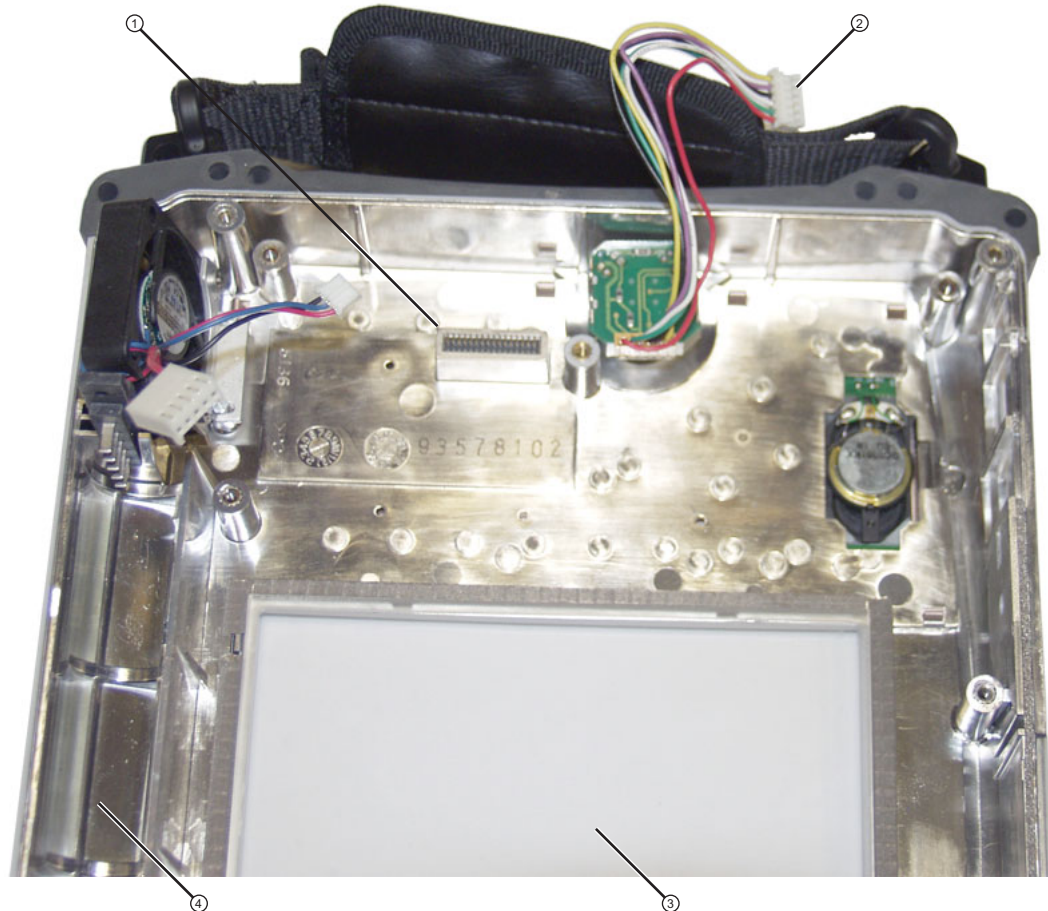

1. Connector J1 of Main Keypad Assembly (mates with J5006 on Mother Board)
2. Rotary Knob Connector (mates with J5010 on Mother Board)
3. Clear Plastic LCD Protector
4. Battery Compartment Section of Case Front

Figure 7-34. Front Case without Mother Board

5. Fasten the Main PCB into place with seven (7) hex standoffs and two (2) pan head screws. Torque these standoffs and screws to 7.5 lbf · in (0.85 N · m).
6. Connect the Battery Power cable to J1003 and the Fan cable to J1002 on the Main PCB (both cables are visible in [Figure 7-34](#), and the connections are shown in [Figure 7-33](#) near the standoffs labelled 8 and 9).

Installing GPS Receiver Module:

7. If the GPS Receiver Module (Option 31) is not installed, then skip ahead to [Step 8](#). If it is equipped, then perform the following sub steps:
 - a. Carefully position the replacement GPS Receiver Module so that it is lined up with its mounting standoff holes and 14-pin header connector on the Main PCB.
 - b. Use extreme care so as to not bend any of the header pins.
 - c. Be careful to not offset the header pins by one row.
 - d. Make sure that the header pins are loosely but correctly positioned before proceeding.
 - e. When perfectly aligned, press on each side of the header strip to mate the connectors and the header pins.
 - f. Insert and tighten the two (2) Phillips-head mounting screws. Note that these screws are shorter than the screws that are used to hold the VNA PCB Assembly in place. Torque these screws to 7.5 lbf · in (0.85 N · m).
 - g. Snap the GPS Antenna Cable MCX connector into place on the GPS Receiver Module. Position the Antenna Cable off the right side of the Case. Do not yet install the GPS Antenna SMA connector in the top connector panel.

Installing VNA PCB Assembly:

[Figure 7-36](#) shows model MS2036C. All steps to remove and replace the VNA PCB Assembly are the same for MS2036C and MS2038C instruments. In model MS2038C, the microwave module replaces the 2 semi-rigid cables. Refer also to the microwave module, item 15 in [Figure 7-7 on page 7-8](#).

If the VNA PCB Assembly is new, then refer first to Section “[Preparing the Replacement VNA Assembly:](#)” on [page 7-38](#) and then continue here. If the original VNA PCB Assembly is being replaced (with cables still attached), or if you have completed performing the preparations in Section “[Preparing the Replacement VNA Assembly:](#)” on [page 7-38](#), then perform the following steps:

8. Place the VNA PCB Assembly upside down next to the Case and the Main PCB (Mother Board).
 - Refer to [Figure 7-35 on page 7-65](#) for an orientation photograph of the Mother Board connections and mounting hardware.
 - Refer to [Figure 7-36 on page 7-66](#) for an orientation photograph of cable routing on the VNA PCB when installed on top of the Mother Board.
9. If the GPS Receiver Module PCB (Option 31) is installed, then ensure that its antenna cable is out of the way.
10. Position the replacement VNA PCB Assembly above the top case and above the Mother Board with the lower edge of the Mother Board and the connectors exposed. Then attach 2 RF cables:
 - Attach the cable from the MCX Connector (J7002) in the top shield of the VNA PCB Assembly (item 4 in [Figure 7-36](#)) to MCX Connector J2201 on the Mother Board (item 7 in [Figure 7-35](#)).
 - Route the cable from the Ext Trig Input connector through the notch to the Main PCB and attach it to Mother Board MMXC connector J3202 Trig In (item 6 in [Figure 7-35](#)).

Installing the GPS Module, Option 31:

If the GPS Receiver Module PCB (Option 31) is not installed, then skip ahead to [Step 11](#). If the GPS Receiver Module PCB is installed, then perform the following sub steps:

- a. Route the GPS Antenna Cable (with its SMA connector from the Main PCB) through the notch between the top connector panel and the PCB, and into its position in the top connector panel.
 - b. Install the lock washer and then the nut.
 - c. Use two 5/16 inch (~8 mm) wrenches to attach the GPS Antenna SMA connector to the top connector panel. Torque the nut to 7.5 lbf · in (0.85 N · m).
11. Carefully position the VNA PCB Assembly over the Main PCB and the eight (8) hex standoffs.

12. Make sure that the top connector panel (part of the VNA PCB Assembly) is correctly positioned and then fasten the VNA PCB Assembly into place by using eight (8) Phillips-head screws. Torque these screws to 7.5 lbf · in (0.85 N · m).

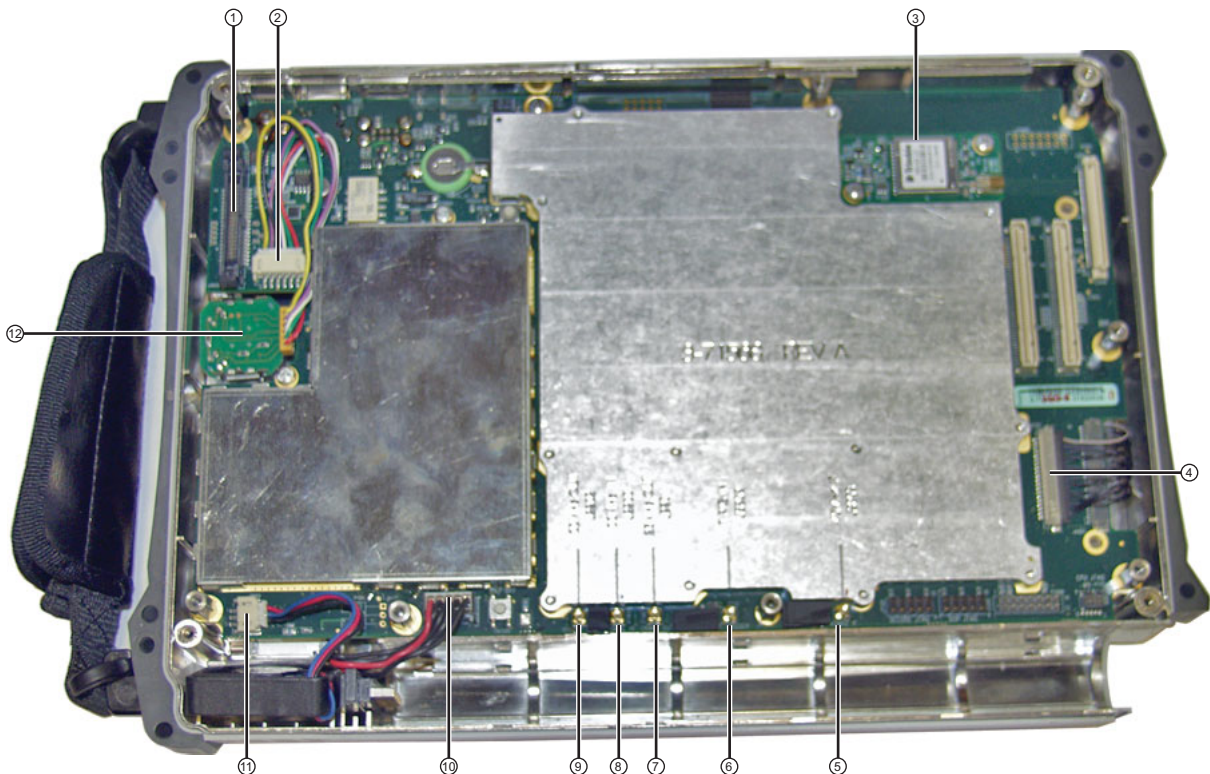

1. Connector J3000, 40-Pin, for ribbon cable to SPA PCB
2. Connector J5010, Twiddle connection for rotary encoder
3. GPS PCB (Option 31)
4. Connector J4202, for multi-conductor signal cable to LCD display
5. MMCX Connector J3203, 140 MHz IF (connects to SPA PCB at J4004)
6. MMCX Connector J3202, External Trigger (BNC connector on top connector panel)
7. MCX Connector J2201, 26 MHz Out (VNA reference, connects to J7002 on upper shield of VNA Module)
8. MMCX Connector J2200, 100 MHz In (connects to SPA PCB at J6002)
9. MMCX Connector J2202 (not used)
10. Connector J1003, Battery connection
11. Connector J1002, Fan connection
12. Rotary Encoder

Figure 7-35. Main PCB (Mother Board) in Case – Connections

Installing GPS Antenna Connector:

13. If the GPS Receiver Module (Option 5) is not installed, then skip ahead to [Step 14](#). Otherwise, perform the following sub steps:
- a. Route the GPS Antenna cable from the Main PCB so that it is located between the top connector panel and the VNA PCB Assembly and routed into its notch
 - b. Install the GPS Antenna SMA connector into the top connector panel, add the lock washer, and finally the nut.
 - c. Use two 5/16 inch (~8 mm) wrenches to attach the GPS Antenna SMA connector to the top connector panel. Torque the nut to 7.5 lbf · in (0.85 N · m).

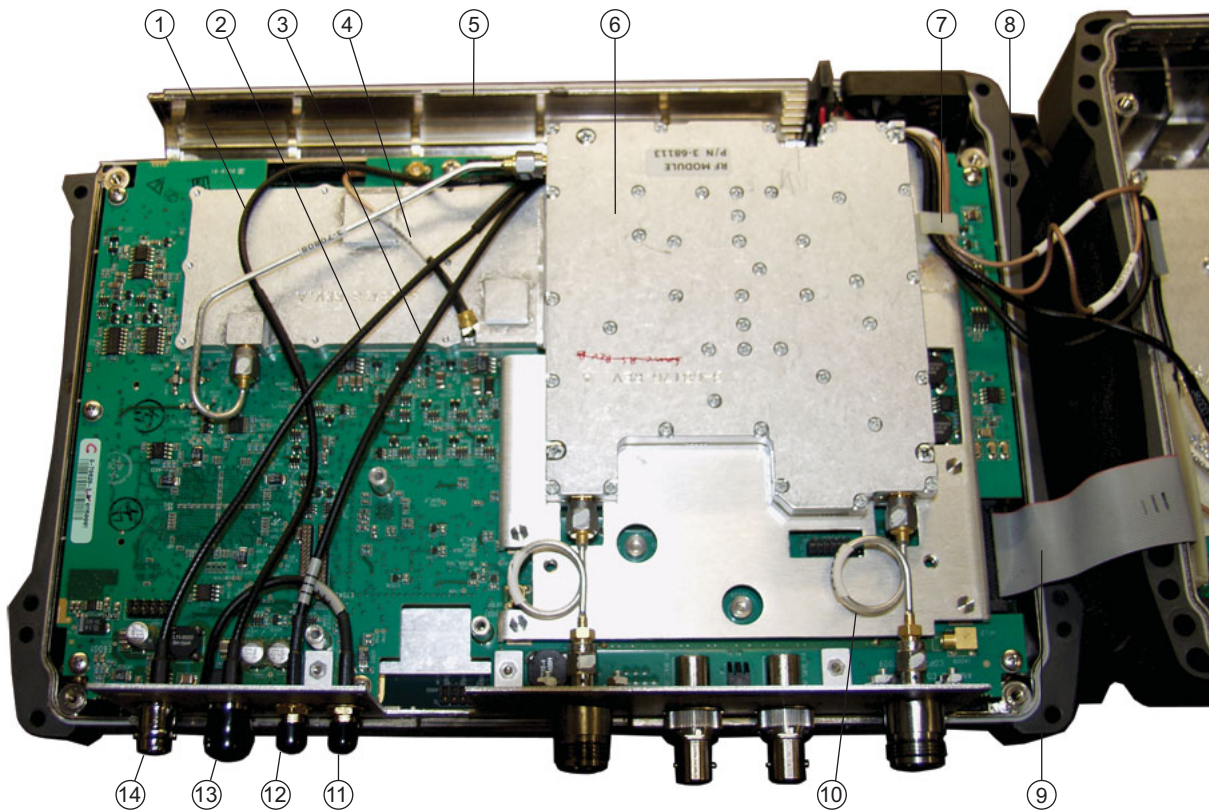

1. External Trigger cable (to MB J3202)
2. External Reference cable (to SPA J6000)
3. 10 MHz Reference Out cable (to SPA J6001)
4. 26 MHz VNA Reference cable (VNA J7002 to MB J2201)
5. Battery Compartment
6. RF Module
7. Cable Tie (part number 3-721-2)
8. Cable bundle between VNA PCB Assembly and SPA PCB (4 cables)
9. Ribbon cable from MB J3000 to SPA J5001
10. Semi-Rigid cable to VNA Port
11. GPS connector
12. 10 MHz REF OUT connector
13. EXT TRIG connector
14. EXT REF connector

Figure 7-36. VNA Assembly – Connected Within Front Case, MS2036C Shown

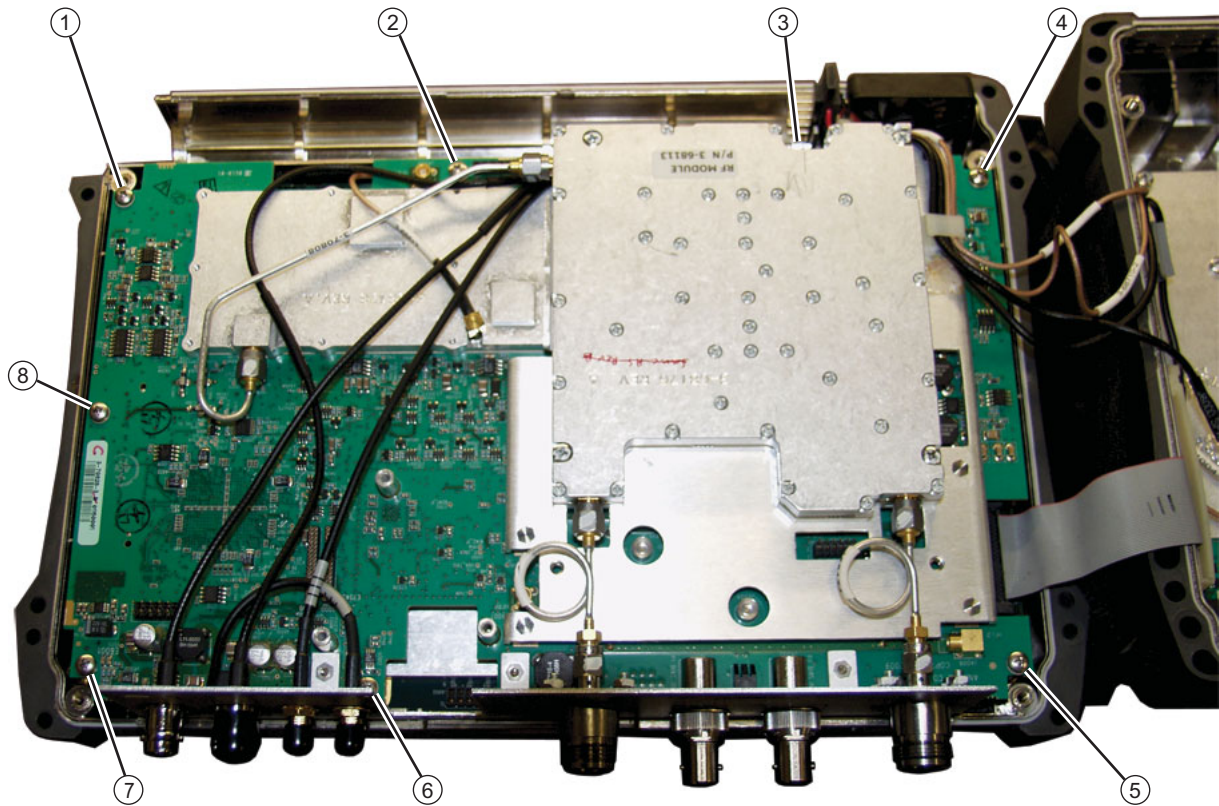

Figure 7-37. VNA PCB Assembly Screw Locations – MS2036C Shown

14. Attach the 2 RF coaxial cables from the VNA PCB to the SPA PCB as follows:

- Route the cable from the Ext Ref In BNC connector on the top connector panel through the notch to the Main PCB and continue routing past the fan to the SPA PCB. Attach the cable to SPA PCB MMCX connector J6000 Ext Ref (item 9 in [Figure 7-38](#)).
- Route the cable from the Ref Out 10 MHz SMA connector on the top connector panel through the notch to the Main PCB and continue routing past the fan to the SPA PCB. Attach the cable to SPA PCB MMCX connector J6001, 10 MHz Out (item 11 in [Figure 7-38](#)).

Replace the cable tie near the fan that holds the 4 RF cables that connect the case front to the case back (item 7 in [Figure 7-36](#), part number 3-721-2, if used).

Caution

All cables along the lower edge of the Mother Board and VNA PCB Assembly must be routed in such a manner that they will not be pinched between, or protrude between, the case halves of the upper battery compartment. If any cable protrudes into the battery compartment when the case is closed, then the cable may be damaged by pinching, or by the battery when it is inserted, or it may prevent battery insertion.

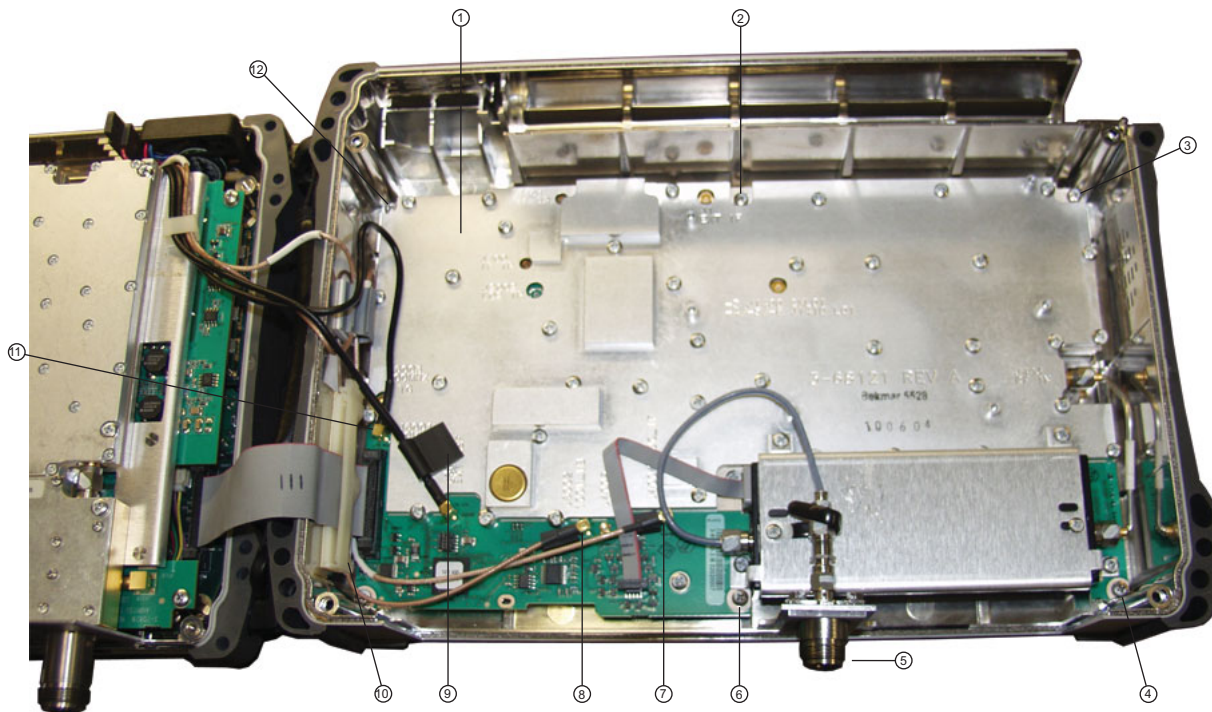

1. PCB
2. Screw (1 of 6 holding PCB to case back)
3. Screw (1 of 6 holding PCB to case back)
4. Screw (1 of 6 holding PCB to case back)
5. SPA RF In Connector (protrudes through connector panel of VAN Assembly when instrument is assembled)
6. Screw (1 of 6 holding PCB to case back)
7. MMCX Connector J4004, 140 MHz IF
8. Connector J6002, 100 MHz to MB (Mother Board)
9. Connector J6000, External Reference In
10. Screw (1 of 6 holding PCB to case back)
11. Connector J6001, 10 MHz Reference Out, located adjacent to J5006 (for ribbon cable)
12. Screw (1 of 6 holding PCB to case back)

Figure 7-38. SPA PCB in Case Back – Cables Connected

15. Snap open the cable clip in the back case (item 13 in [Figure 7-39](#)), and insert the four single RF cables from the Mother Board and the VNA PCB Assembly to the SPA PCB at MMCX connectors J6000, J6001, J6002, and J4004.
 - a. J6000 (item 9 in [Figure 7-38](#)) is for the External Reference cable from the Ext. Ref. connector on the top connector panel (attached to the VNA Assembly).
 - b. J6001 (item 11 in [Figure 7-38](#)) is for the 10 MHz Ref Out connector on the top connector panel (attached to the VNA Assembly).
 - c. J6002 (item 8 in [Figure 7-38](#)) is for the 100 MHz In connector. The other end is connected to J2200 on the Mother Board (item 8 in [Figure 7-35](#) on page 7-65).
 - d. J4004 (item 7 in [Figure 7-38](#)) is for the 140 MHz IF connector. The other end is connected to J3203 on the Mother Board (item 5 in [Figure 7-35](#)).
16. Close the cable clip (item 13 in [Figure 7-39](#)) by pressing inward. It snaps into place.
17. Connect the ribbon cable from Mother Board connector J3000 to the SPA PCB at connector J5001, and then close the cable clamp (item 11 in [Figure 7-39](#)). It snaps closed, as shown in [Figure 7-38](#).

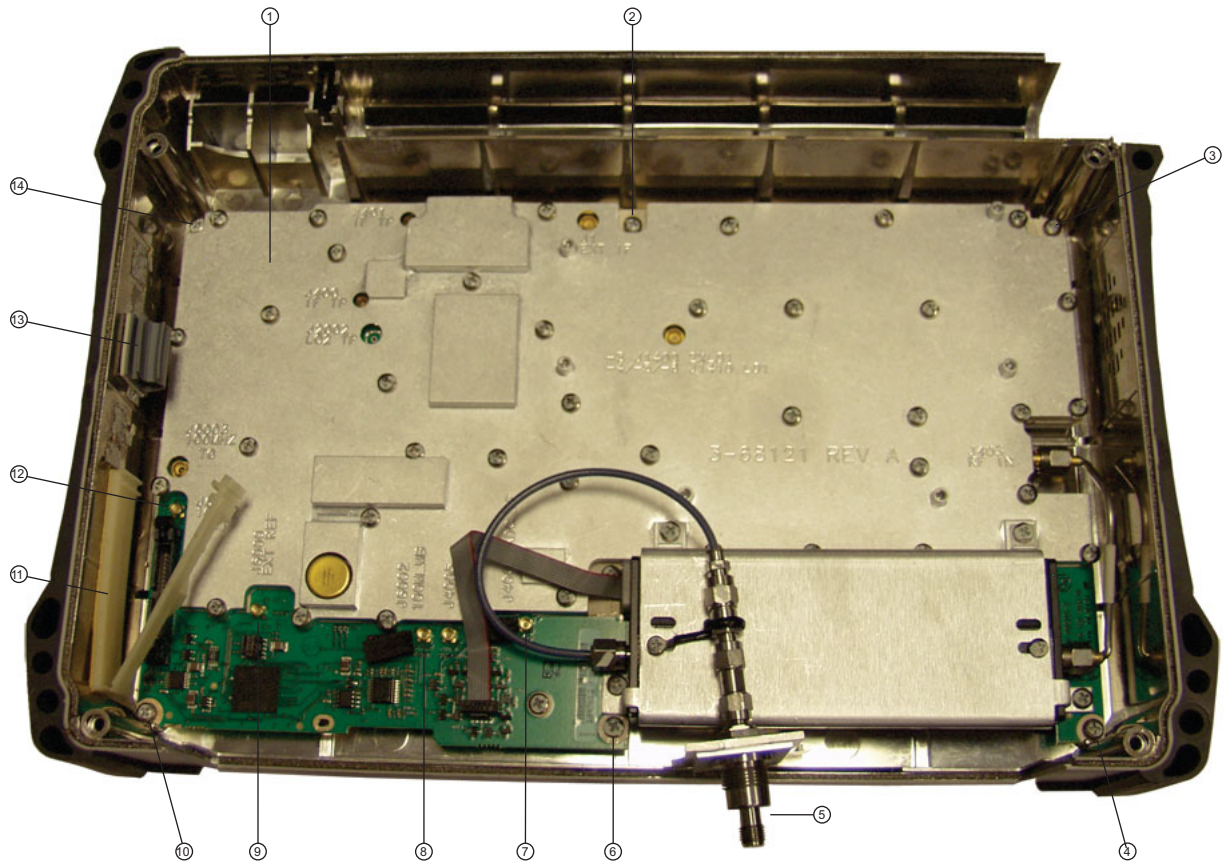

1. SPA PCB inside back case
2. PCB mounting screw (1 of 6)
3. PCB mounting screw (1 of 6)
4. PCB mounting screw (1 of 6)
5. SPA RF In connector (remains with SPA PCB)
6. PCB mounting screw (1 of 6)
7. J4004 MMCX connector for cable to MB J3203 (140 MHz IF)
8. J6002 MMCX connector for cable to MB J2200 (100 MHz)
9. J6000 MMCX connector for cable to External Reference BNC connector on instrument top connector panel
10. PCB mounting screw (1 of 6)
11. Ribbon cable clamp
12. J6001 MMCX connector for cable to 10 MHz Reference Out SMA connector on instrument top connector panel
13. Cable clip
14. PCB mounting screw (1 of 6)

Figure 7-39. SPA PCB Screw Locations

18. The two halves of the instrument can now be safely joined. The **Case Back Assembly** contains the Spectrum Analyzer (SPA) board. The **Case Front Assembly** contains all of the other serviceable parts.

19. Ensure that the 4 RF cables (connecting case front and case back) are safely tucked in along the bottom of the Mother Board.

Caution All cables along the lower edge of the Mother Board and VNA PCB Assembly must be routed in such a manner that they will not be pinched between, or protrude between, the case halves of the upper battery compartment. If any cable protrudes into the battery compartment when the case is closed, then the cable may be damaged by pinching, or by the battery when it is inserted, or it may prevent battery insertion.

Closing the Case Assembly:

20. Replace the Case Back Assembly on top of the Case Front Assembly, making sure that the top connector panel is correctly centered in its mounting groove and that all cables are clear.

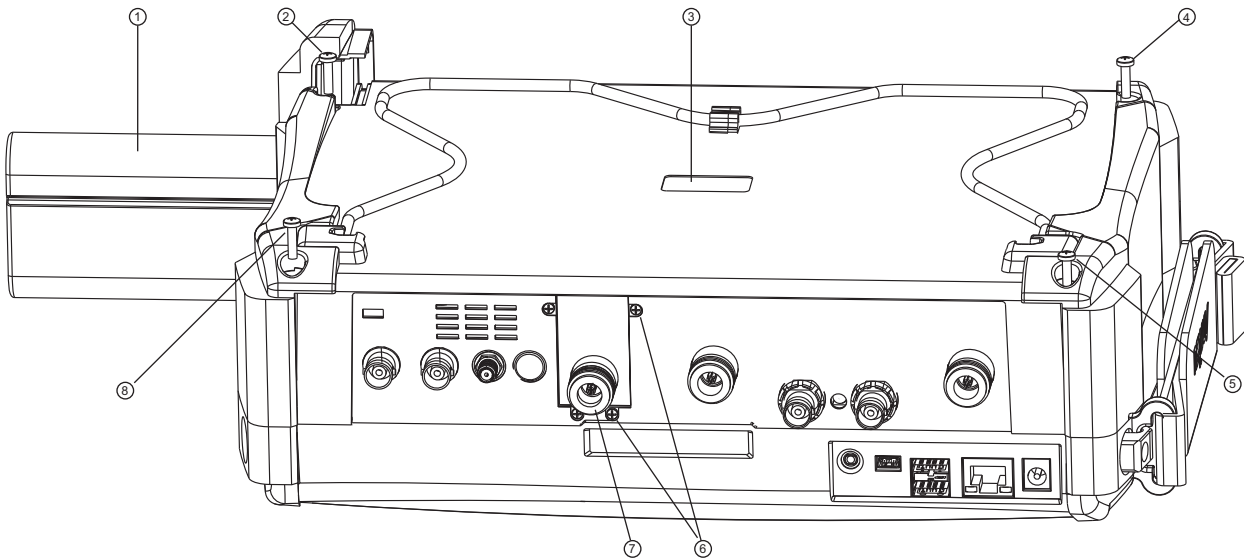

1. Battery
2. Case Back screw (1 of 4)
3. Recess for serial number label (serial number of SPA PCB)
4. Case Back screw (1 of 4)
5. Case Back screw (1 of 4)
6. Screws (4) to hold SPA RF In connector mounting plate to top connector panel
7. SPA RF In port (supplied with SPA PCB)
8. Case Back screw (1 of 4)

Figure 7-40. Case for MS203xC

21. Ensure that the SPA RF In connector mounting plate is properly engaged within the top connector panel. Ensure that the top connector panel is correctly centered in its mounting groove and that all cables are clear.
- a. Insert and tighten the four SPA connector plate mounting screws (refer to item 6 in [Figure 7-40](#)). Torque these screws to 4.0 lbf·in (0.45 N·m).
 - b. Insert and tighten the four case mounting screws (refer to [Figure 7-40](#)). Torque the screws to 7.5 lbf·in (0.85 N·m).

Installing Battery:

Refer to [Section 5-4 “Battery Pack Removal and Replacement”](#) on page 5-3.

22. Install the Battery.
23. Install the Battery Door.

Restarting the Instrument:

24. Restart the instrument.
25. Perform a function check to verify all repairs and part replacements.

7-27 Replacing Fan Assembly – ND70948

This replacement procedure provides instructions for replacing the Fan Assembly for all variants of the MS203xC VNA Masters. In general, the case is opened and the Fan Assembly is replaced without disturbing any of the PCBs, and without disconnecting any RF cables. The entire Fan Assembly is then exchanged for a replacement part.

Part Numbers

- ND70948 – Fan Assembly for MS2036C and MS2038C instruments

Procedure

Opening the Case:

1. Open the case as described in [Section 7-17 “Opening the Instrument Case”](#) on page 7-24.
2. Follow [Step 1](#) through [Step 7](#).

[Figure 7-41](#) shows model MS2036C. All steps to remove and replace the Fan Assembly are the same for MS2036C and MS2038C instruments.

Disconnecting GPS Antenna Cable:

3. If the GPS Receiver Module PCB (Option 31) is NOT installed, then skip ahead to [Step 4](#), noting the preliminary directions in section [“Moving the VNA PCB Assembly:”](#). If the GPS Receiver Module PCB is installed, then perform the following sub steps:
 - a. Use two 5/16 inch (\cong 8 mm) wrenches to disconnect the GPS Antenna SMA connector (item 11 in [Figure 7-18](#)) from the top connector panel.
 - b. Remove the nut and lock washer and then remove the SMA connector from the top connector panel.
 - c. Replace the lock washer and nut onto the SMA connector for safe keeping.
 - d. Route the cable to the side, clearing the notch and the top connector panel, so it is clear of the VNA PCB Assembly.
 - e. Removing the GPS Antenna SMA connector also provides easier access to one of the VNA PCB Assembly mounting screws.

Moving the VNA PCB Assembly:

In this procedure, the VNA PCB Assembly is not removed completely, but is moved only far enough to expose the required Fan Assembly components.

Identifying VNA PCB Assembly Mounting Screws:

[Figure 7-41](#) shows model MS2036C. All steps to remove and replace the VNA PCB Assembly are the same for MS2036C and MS2038C instruments. In model MS2038C, the microwave module replaces the 2 semi-rigid cables.

4. Using [Figure 7-41](#), identify the locations of the eight (8) Phillips-head mounting screws that hold the VNA Assembly PCB in place. [Figure 7-42](#) shows the 8 hexagonal standoffs on the Mother Board. The 8 VNA Assembly PCB screws attach to the 8 hexagonal standoffs in the Main PCB (Mother Board).

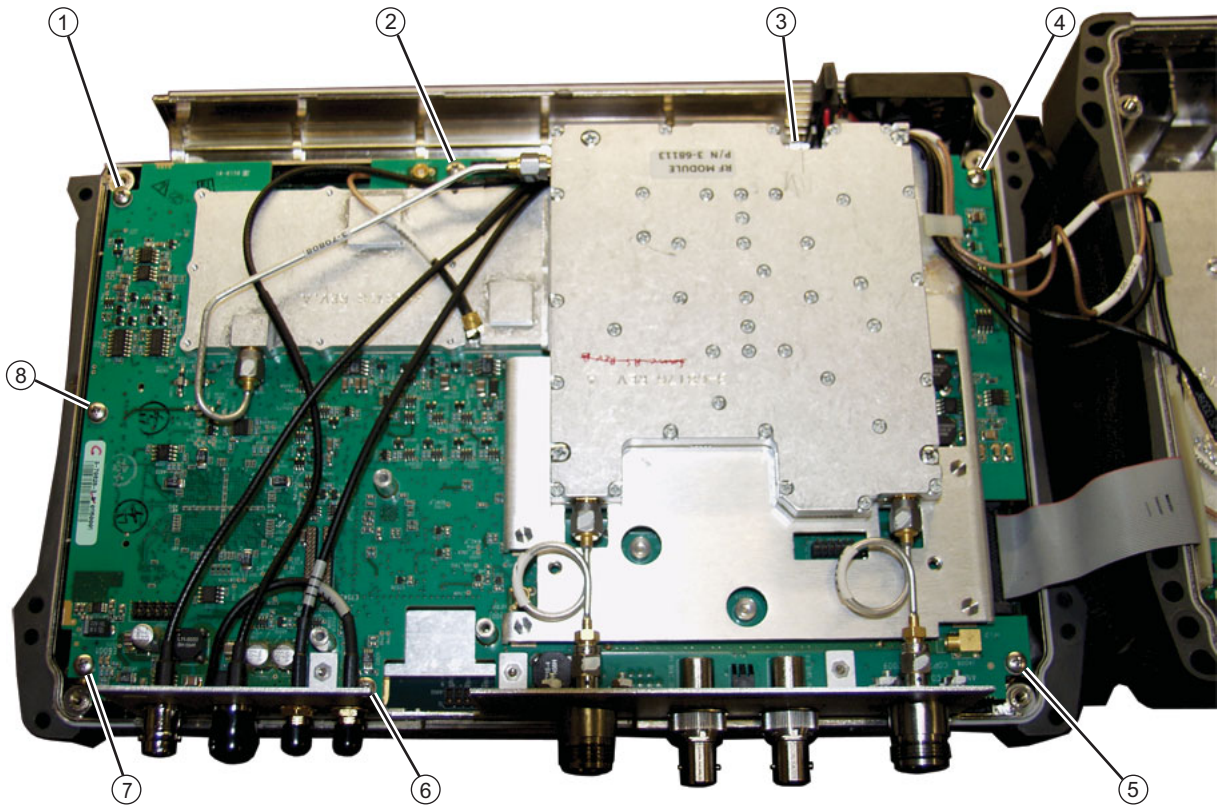

Figure 7-41. VNA PCB Assembly Screw Locations – MS2036C Shown

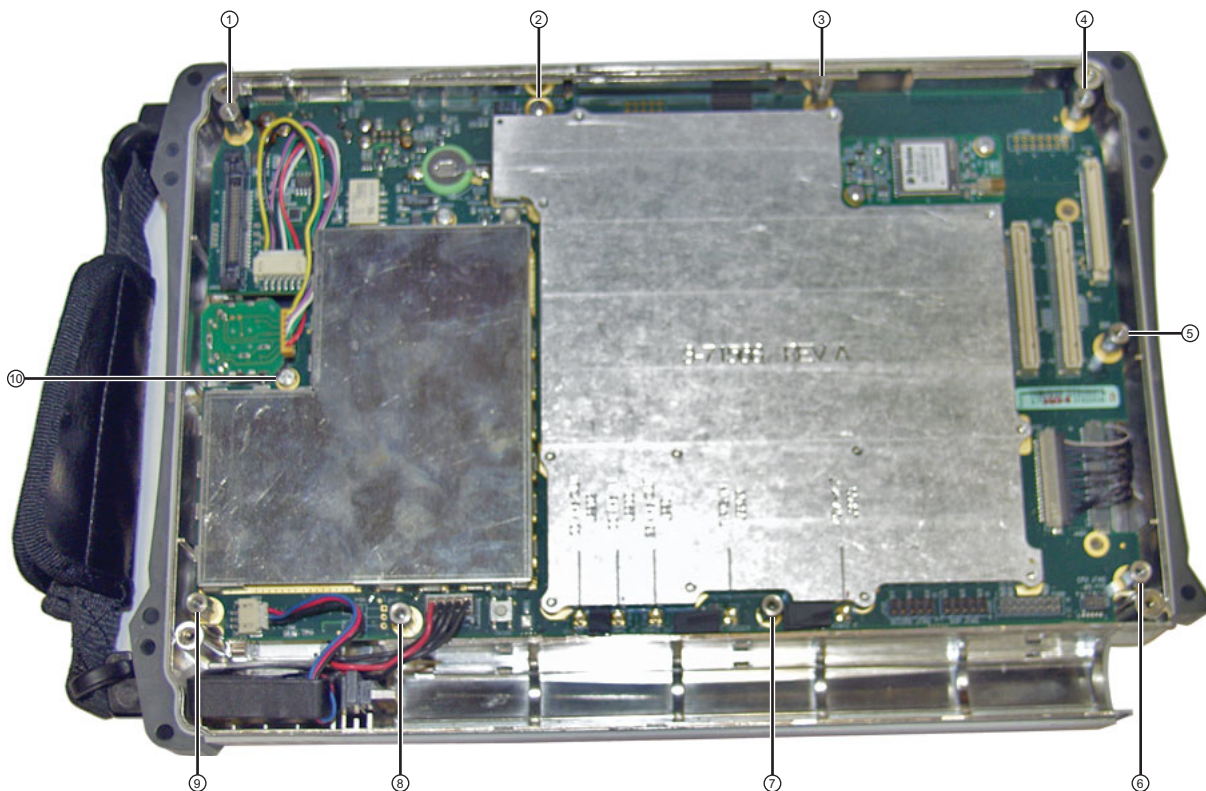
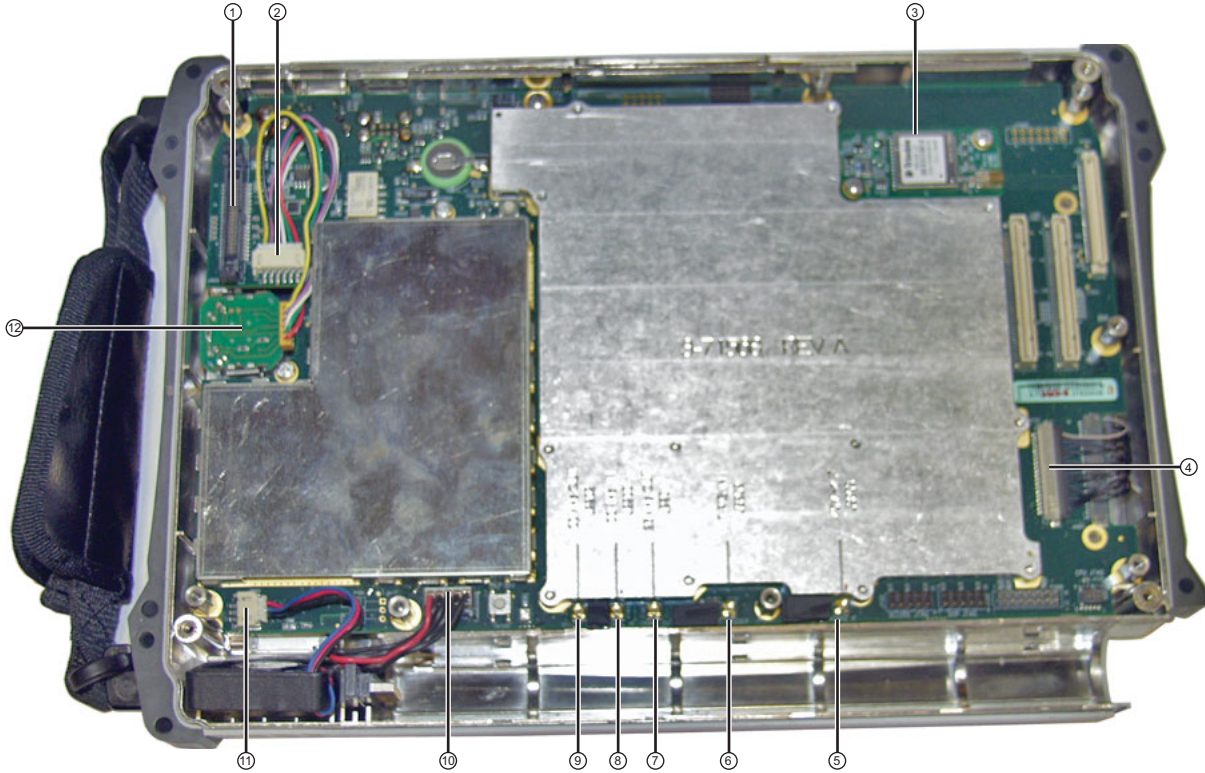

Figure 7-42. Main PCB (Mother Board) in Case – Standoffs and Screws

5. Using a Phillips-head screwdriver, remove the eight (8) screws holding the VNA PCB Assembly in place.
6. The VNA PCB Assembly is connected to the Mother Board and the SPA PCB with several cables. None of these cables are disconnected during Fan Assembly replacement. Observe all cables as the VNA PCB Assembly is moved and then replaced. Take care not to stress any of these cables.
7. Lift the top edge of the VNA Assembly (with the attached top connector panel) and carefully move the VNA Assembly up and in the direction of the top of the case in order to expose the cable connection for the Fan Assembly, connector J1002 on the Mother Board. Refer to item 11 in Figure 7-43. Note that the VNA PCB Assembly and the SPA PCB Assembly cables are not shown in Figure 7-43.



1. Connector J3000, 40-Pin, for ribbon cable to SPA PCB
2. Connector J5010, Twiddle connection for rotary encoder
3. GPS PCB (Option 31)
4. Connector J4202, for multi-conductor signal cable to LCD display
5. MMCX Connector J3203, 140 MHz IF (connects to SPA PCB at J4004)
6. MMCX Connector J3202, External Trigger (BNC connector on top connector panel)
7. MCX Connector J2201, 26 MHz Out (VNA reference, connects to J7002 on upper shield of VNA Module)
8. MMCX Connector J2200, 100 MHz In (connects to SPA PCB at J6002)
9. MMCX Connector J2202, not used for MS203xC models.
10. Connector J1003, Battery connection
11. Connector J1002, Fan connection
12. Rotary Encoder

Figure 7-43. Main PCB (Mother Board) in Case – Connections

8. Gently pry the fan cable from Mother Board connector J1002. Refer to item 2 in [Figure 7-44](#).



1. Fan
2. Fan Cable connected to MB

Figure 7-44. Removing the Fan

9. Use a Phillips-head screwdriver to remove the 2 mounting screws that hold the Fan Assembly in place, and then remove the Fan Assembly.

Installing the Fan Assembly:

10. Install the replacement Fan Assembly and tighten the 2 mounting screws. Torque these screws to 4.0 lbf · in (0.45 N · m).
11. Connect the fan cable to connector J1002 on the Mother Board.

Installing the VNA PCB Assembly:

12. Carefully reposition the VNA PCB Assembly over the Mother Board and prepare to secure it in place.
13. Using [Figure 7-41](#), identify the locations of the eight (8) Phillips-head mounting screws that hold the VNA Assembly PCB in place. [Figure 7-42](#) shows the 8 hexagonal standoffs on the Mother Board. The 8 VNA Assembly PCB screws attach to the 8 hexagonal standoffs in the Main PCB (Mother Board).
14. Check all cables to be sure that they are securely connected and that the RF cables are outside the standoffs on the Mother Board, and are tucked in and kept away from the case parts, especially the battery compartment.

Caution

All cables along the lower edge of the Mother Board and VNA PCB Assembly must be routed in such a manner that they will not be pinched between, or protrude between, the case halves of the upper battery compartment. If any cable protrudes into the battery compartment when the case is closed, then the cable may be damaged by pinching, or by the battery when it is inserted, or it may prevent battery insertion.

15. Make sure that the VNA PCB Assembly is correctly positioned over the standoffs on the Mother Board, and then fasten it into place using eight (8) Phillips-head screws.
Torque these screws to 7.5 lbf ·in (0.85 N ·m).

Installing the GPS Antenna SMA Connector:

16. If the GPS Receiver Module (Option 5) is not installed, then skip ahead to [Step 17](#). Otherwise, perform the following sub steps:
 - a. Route the GPS Antenna cable from the Main PCB so that it is located between the top connector panel and the VNA PCB Assembly and routed into its notch
 - b. Install the GPS Antenna SMA connector into the top connector panel, add the lock washer, and finally the nut.
 - c. Use two 5/16 inch (~8 mm) wrenches to attach the GPS Antenna SMA connector to the top connector panel. Torque the nut to 7.5 lbf ·in (0.85 N ·m).
17. The next step is to close the case. Verify that all cables are properly positioned. Refer to section “[Closing the Case](#)” on [page 7-27](#), following any required steps in that section. Also refer to [Figure 7-45](#) on [page 7-77](#).

Installing Battery:

Refer to [Section 5-4 “Battery Pack Removal and Replacement”](#) on [page 5-3](#).

18. Install the Battery.
19. Install the Battery Door.

Restarting the Instrument:

20. Restart the instrument.
21. Perform a function check to verify all repairs and part replacements.

Replacing Case Rear Assembly:

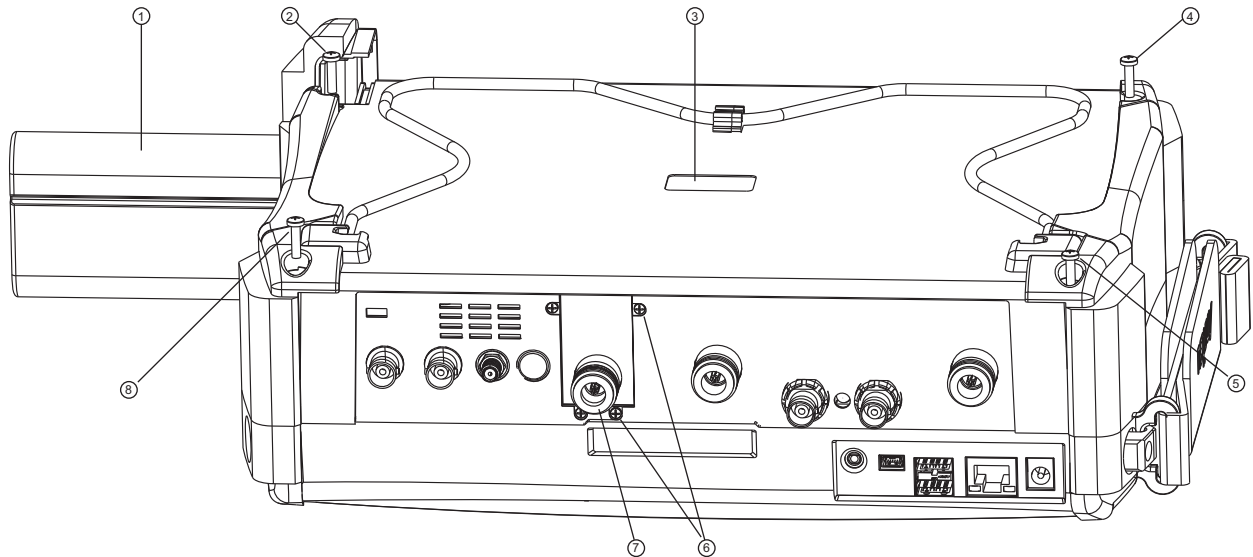

1. Battery
2. Case Back screw (1 of 4)
3. Recess for serial number label (serial number of SPA PCB)
4. Case Back screw (1 of 4)
5. Case Back screw (1 of 4)
6. Screws (4) to hold SPA RF In connector mounting plate to top connector panel
7. SPA RF In port (supplied with SPA PCB)
8. Case Back screw (1 of 4)

Figure 7-45. Case for MS203xC

22. Replace the Case Bottom Assembly. Ensure that the SPA connector plate is properly engaged within the top connector panel. Ensure that the top connector panel is correctly centered in its mounting groove in the case back and that all cables are clear.
 - a. Insert and tighten the four SPA connector plate mounting screws. Torque these screws to 4.0 lbf · in (0.45 N · m).
 - b. Insert and tighten the four case mounting screws. Torque the screws to 7.5 lbf · in (0.85 N · m).

Chapter 8 — Troubleshooting

8-1 Introduction

This chapter describes the primary troubleshooting operations that can be performed. Perform the troubleshooting suggestions in the order in which they are listed.

Only qualified service personnel should replace internal assemblies. Major subassemblies that are shown in the replaceable parts list are typically the items that may be replaced.

Because they are highly fragile, items that must be soldered may not be replaced without special training. Removal of RF shields from PC boards or adjustment of screws on or near the RF shields will de tune sensitive RF circuits and will result in degraded instrument performance.

8-2 Turn-on Problems

Unit Cannot Boot Up (Battery Powered)

Unit cannot boot up, no activity occurs when the **On/Off** key is pressed:

1. Battery may have been fully discharged. Use an external charger (Anritsu PN 2000-1374) to charge a completely discharged battery.
2. Battery may be the wrong type. Use only Anritsu approved battery packs. Some non-approved battery packs will fit into the MS202xC and MS203xC but they are electrically incompatible and will not charge correctly.
3. **On/Off** switch may have damaged. Replace the rubber keypad Rubber Membrane.
4. Main PCB may have failed. Replace the Main PCB Assembly.

Unit Cannot Boot Up (AC Powered)

1. External AC power adapter may have failed or be the wrong type. Replace the external power adapter.
2. **On/Off** switch may have damaged. Replace the rubber keypad rubber Membrane.
3. Main PCB may have failed. Replace the Main PCB Assembly.

Unit Cannot Complete Boot-Up

Unit begins the boot process, but does not complete boot-up:

1. Firmware update may not have completed. Reload firmware.

Note	Run Master Software Tools on a PC to download the latest firmware and load the firmware to a blank formatted USB memory stick, insert the USB memory stick to the USB A connector of the VNA Master and then load the firmware via the USB port of the instrument.
-------------	--

2. Main PCB may have failed. Replace the Main PCB Assembly.

Unit Boots with No Display

Unit produces a ding sound after a while, but with no display:

1. If the display is dim, then check the Brightness setting under the System Menu | System Options.
2. LCD may have failed. Replace the LCD Display Assembly.
3. The Main PCB may have failed. Replace the Main PCB Assembly.

Boot-up Self Test Fails

The unit boot-up self test fails with an error message:

1. Perform a Master Reset (Press **Esc** and **On/Off** key to turn on power to the unit after power off the unit).
2. The Main PCB may have failed. Replace the Main PCB Assembly.

8-3 Operating Problems

IF Out of Range Message (Vector Network Analyzer Mode)

1. VNA PCB Assembly may have damaged. Replace VNA PCB Assembly.

Lock Error Message

Vector Network Analyzer Mode Related

1. VNA PCB Assembly may have damaged. Replace VNA PCB Assembly.
2. Check the condition of the 26 MHz Inter-connect cable connections on both the Main PCB and VNA Module.
3. Main PCB may have failed. Replace Main PCB Assembly.

Spectrum Analyzer Mode Related

1. This message normally appears for 2 to 3 seconds when an external 10 MHz Reference is applied.
2. Spectrum Analyzer PCB may have failed. Replace Spectrum Analyzer PCB Assembly.
3. Main PCB may have failed. Replace Main PCB Assembly.

Inaccurate Amplitude Measurements (Spectrum Analyzer Mode)

1. Inspect the Spectrum Analyzer RF In connector for damage.
2. Spectrum Analyzer PCB Assembly may have damaged or failed. Replace Spectrum Analyzer PCB Assembly.

Option 5, Power Monitor Problems

1. Verify correct operation of RF detector.
2. Power Monitor PCB Assembly Option 5 PCB may have failed. Replace Option 5 PCB.

Option 10, VNA Bias Tee Problems

1. Verify that VNA Bias Tee Voltage and Current are within their respective expected range.
2. VNA PCB Assembly may have failed. Replace VNA PCB Assembly.

Option 31, GPS Problems

1. Verify that GPS Bias Tee is functional.
2. Swap GPS Antenna.
3. GPS Receiver Module may have failed. Replace GPS Receiver Module.

Appendix A — Test Records

A-1 Introduction

This appendix provides test records that can be used to record the performance of the MS2026C, MS2028C, MS2036C, and MS2038C VNA Master.

Make a copy of the following Test Record pages and document the measured values each time performance verification is performed. Continuing to document this process each performance verification session provides a detailed history of the instrument's performance.

The following test record forms are available:

- [“MS2026C VNA Master Test Record” on page A-2](#)
- [“MS2028C VNA Master Test Record” on page A-3](#)
- [“MS2036C VNA Master Test Record” on page A-4](#)
- [“MS2038C VNA Master Test Record” on page A-14](#)

Instrument Information

Serial Number:	Firmware Revision:	Operator:
Options:		Date:

A-2 MS2026C VNA Master Test Record**VNA Frequency Accuracy – MS2026C****Table A-1.** VNA Frequency Accuracy

VNA Output Frequency	Specification	Frequency Counter Reading
2.6 GHz	± 3.9 kHz	kHz

VNA Transmission Dynamic Range – MS2026C

_____ Attached Test Data Report

VNA S-Parameter Measurements Verification – MS2026C

_____ Attached Verification Report

Power Monitor Measurement Accuracy (For instruments with Option 5) – MS2026C**Table A-2.** Power Monitor Measurement Accuracy

Power Level @ 1 GHz	Specification	Measured Value
+13 dBm	± 1 dB	dBm
0 dBm	± 1 dB	dBm
-7 dBm	± 1 dB	dBm
-21 dBm	± 1 dB	dBm
-40 dBm	± 1 dB	dBm

Serial Number:	Firmware Revision:	Operator:
Options:		Date:

A-3 MS2028C VNA Master Test Record

VNA Frequency Accuracy – MS2028C

Table A-3. VNA Frequency Accuracy

VNA Output Frequency	Specification	Frequency Counter Reading
2.6 GHz	± 3.9 kHz	kHz

VNA Transmission Dynamic Range – MS2028C

_____ Attached Test Data Report

VNA S-Parameter Measurements Verification – MS2028C

_____ Attached Verification Report

Power Monitor Measurement Accuracy (For instruments with Option 5) – MS2028C

Table A-4. Power Monitor Measurement Accuracy

Power Level @ 1 GHz	Specification	Measured Value
+13 dBm	± 1 dB	dBm
0 dBm	± 1 dB	dBm
-7 dBm	± 1 dB	dBm
-21 dBm	± 1 dB	dBm
-40 dBm	± 1 dB	dBm

Serial Number:	Firmware Revision:	Operator:
Options:		Date:

A-4 MS2036C VNA Master Test Record

VNA Frequency Accuracy – MS2036C

Table A-5. VNA Frequency Accuracy

VNA Output Frequency	Specification	Frequency Counter Reading
2.6 GHz	± 3.9 kHz	kHz

VNA Transmission Dynamic Range – MS2036C

_____ Attached Test Data Report

VNA S-Parameter Measurements Verification – MS2036C

_____ Attached Verification Report

Serial Number:	Firmware Revision:	Operator:
Options:		Date:

Spectrum Analyzer Residual Spurious Response – MS2036C

Table A-6. Spectrum Analyzer Residual Spurious Response with Preamp Off

Start Freq	Stop Freq	RBW	VBW	Specification	Measured Values
9 kHz	100 kHz	300 Hz	10 Hz	≤ -90 dBm	dBm
100 kHz	10 MHz	300 Hz	100 Hz	≤ -90 dBm	dBm
10 MHz	2 GHz	30 kHz	3 kHz	≤ -90 dBm	dBm
2 GHz	4 GHz	10 kHz	1 kHz	≤ -90 dBm	dBm
4 GHz	5.35 GHz	10 kHz	300 Hz	≤ -90 dBm	dBm
5.35 GHz	7.2 GHz	3 kHz	300 Hz	≤ -90 dBm	dBm
7.2 GHz	8.2 GHz	3 kHz	300 Hz	≤ -90 dBm	dBm
8.2 GHz	9 GHz	3 kHz	300 Hz	≤ -90 dBm	dBm

Table A-7. Spectrum Analyzer Residual Spurious Response with Preamp On

Start Freq	Stop Freq	RBW	VBW	Specification	Measured Values
1 MHz	10 MHz	3 kHz	300 Hz	≤ -100 dBm	dBm
10 MHz	2 GHz	30 kHz	3 kHz	≤ -100 dBm	dBm
2 GHz	4 GHz	30 kHz	3 kHz	≤ -100 dBm	dBm
4 GHz	5.35 GHz	30 kHz	3 kHz	≤ -100 dBm	dBm
5.35 GHz	7.2 GHz	30 kHz	1 kHz	≤ -100 dBm	dBm
7.2 GHz	9 GHz	30 kHz	3 kHz	≤ -100 dBm	dBm

Serial Number:	Firmware Revision:	Operator:
Options:		Date:

Spectrum Analyzer Displayed Average Noise Level (DANL) – MS2036C

Table A-8. Spectrum Analyzer DANL with Preamp Off

Start Freq	Stop Freq	RBW	VBW	Specification	Measured Value (100 kHz RBW)	Calculated Value (1 Hz RBW)
10 MHz	4 GHz	100 kHz	1 kHz	≤ -141 dBm	dBm	dBm
4 GHz	9 GHz	100 kHz	1 kHz	≤ -134 dBm	dBm	dBm

Table A-9. Spectrum Analyzer DANL with Preamp On

Start Freq	Stop Freq	RBW	VBW	Specification	Measured Value (100 kHz RBW)	Calculated Value (1 Hz RBW)
10 MHz	4 GHz	100 kHz	1 kHz	≤ -160 dBm	dBm	dBm
4 GHz	9 GHz	100 kHz	1 kHz	≤ -156 dBm	dBm	dBm

Spectrum Analyzer Frequency Accuracy – MS2036C

Table A-10. Spectrum Analyzer Frequency Accuracy

Frequency	Specification	Measured Value	Deviation
1 GHz	± 300 Hz	GHz	Hz
7 GHz	± 2.1 kHz	GHz	kHz

Spectrum Analyzer Frequency Accuracy (Option 31, GPS) – MS2036C

Table A-11. Spectrum Analyzer Frequency Accuracy with GPS On

Frequency	Specification	Measured Value	Deviation
7 GHz	$< \pm 350$ Hz	GHz	Hz

Serial Number:	Firmware Revision:	Operator:
Options:		Date:

Spectrum Analyzer Single Side Band (SSB) Phase Noise – MS2036C

Table A-12. Spectrum Analyzer SSB Phase Noise

Offset Frequency	Specification	Measured Value	Calculated Value
10 kHz	≤ -100 dBc/Hz	dB	dBc/Hz
100 kHz	≤ -102 dBc/Hz	dB	dBc/Hz
1 MHz	≤ -107 dBc/Hz	dB	dBc/Hz
10 MHz	≤ -120 dBc/Hz	dB	dBc/Hz

Spectrum Analyzer Spurious Response (Second Harmonic Distortion) – MS2036C

Table A-13. Spectrum Analyzer Spurious Response (Second Harmonic Distortion)

Frequency	Specification	Measured Value	2nd Harmonic Level
50.1 MHz		dBm	
100.2 MHz	≤ -54 dBc	dBm	dBc

Spectrum Analyzer Input Related Spurious (IRS) Signals – MS2036C

Table A-14. Spectrum Analyzer Input Related Spurious (IRS) Signals

Frequency	Specification	Measured Value	Calculated IRS
1000 MHz		dBm	
719 MHz to 721 MHz	≤ -60 dBc	dBm	dBc
3273 MHz		dBm	
2423 MHz to 3271 MHz	≤ -60 dBc	dBm	dBc
3275 MHz to 4123 MHz	≤ -60 dBc	dBm	dBc
8000 MHz		dBm	
7719 MHz to 7721 MHz	≤ -60 dBc	dBm	dBc

Serial Number:	Firmware Revision:	Operator:
Options:		Date:

Spectrum Analyzer Resolution Bandwidth Accuracy – MS2036C

Table A-15. Spectrum Analyzer Resolution Bandwidth Accuracy

RBW	Span	VBW	Lower Limit	Measured Values	Upper Limit
10 MHz	20 MHz	1 MHz	9 MHz	MHz	11 MHz
3 MHz	6 MHz	300 kHz	2.7 MHz	MHz	3.3 MHz
1 MHz	2 MHz	100 kHz	0.9 MHz	MHz	1.1 MHz
300 kHz	600 kHz	30 kHz	270 kHz	kHz	330 kHz
100 kHz	200 kHz	10 kHz	90 kHz	kHz	110 kHz
30 kHz	60 kHz	3 kHz	27 kHz	kHz	33 kHz
10 kHz	20 kHz	1 kHz	9 kHz	kHz	11 kHz
3 kHz	6 kHz	300 Hz	2.7 kHz	kHz	3.3 kHz
1 kHz	2 kHz	100 Hz	0.9 kHz	kHz	1.1 kHz
300 Hz	600 Hz	30 Hz	270 Hz	Hz	330 Hz
100 Hz	200 Hz	10 Hz	90 Hz	Hz	110 Hz
30 Hz	60 Hz	3 Hz	27 Hz	Hz	33 Hz
10 Hz	20 Hz	3 Hz	9 Hz	Hz	11 Hz
3 Hz	10 Hz	1 Hz	2.7 Hz	Hz	3.3 Hz
1 Hz	2 Hz	1 Hz	0.9 Hz	Hz	1.1 Hz

Serial Number:	Firmware Revision:	Operator:
Options:		Date:

Spectrum Analyzer Amplitude Accuracy – MS2036C

Note The listed Amplitude Accuracy specifications apply when the instrument is being verified in an environment between 20°C and 30°C after a 30 minute warm-up. For an instrument that is not being verified in a temperature controlled environment but within a temperature range between –10°C and 50°C and after a 60 minute warm-up, add ±1 dB to the Amplitude Accuracy specification.

Table A-16. Spectrum Analyzer 50 MHz Amplitude Accuracy Setup Table

Test Power Level @ 50 MHz	Required Sensor B Reading
0 dBm	dBm
–4 dBm	dBm
–10 dBm	dBm
–14 dBm	dBm
–20 dBm	dBm
–24 dBm	dBm
–30 dBm	dBm
–34 dBm	dBm
–40 dBm	dBm
–44 dBm	dBm
–50 dBm	dBm

Table A-17. Spectrum Analyzer 50 MHz Amplitude Accuracy

Test Power	Specification	Reference Level	Atten Lvl	Measured Value	Deviation
0 dBm	±1.3 dB	10 dBm	30 dB	dBm	dB
–4 dBm	±1.3 dB	10 dBm	30 dB	dBm	dB
–10 dBm	±1.3 dB	0 dBm	20 dB	dBm	dB
–14 dBm	±1.3 dB	0 dBm	20 dB	dBm	dB
–20 dBm	±1.3 dB	–10 dBm	10 dB	dBm	dB
–24 dBm	±1.3 dB	–10 dBm	10 dB	dBm	dB
–30 dBm	±1.3 dB	–20 dBm	0 dB	dBm	dB
–34 dBm	±1.3 dB	–20 dBm	0 dB	dBm	dB
–40 dBm	±1.3 dB	–30 dBm	0 dB	dBm	dB
–44 dBm	±1.3 dB	–30 dBm	0 dB	dBm	dB
–50 dBm	±1.3 dB	–40 dBm	0 dB	dBm	dB

Serial Number:	Firmware Revision:	Operator:
Options:		Date:

Spectrum Analyzer Amplitude Accuracy – MS2036C (continued)

Table A-18. Spectrum Analyzer Amplitude Accuracy Across Frequency Setup Table

Frequency	Required Sensor B reading for –2 dBm @Attenuator output	Required Sensor B reading for –30 dBm @Attenuator output
10.1 MHz	dBm	dBm
100 MHz	dBm	dBm
500 MHz	dBm	dBm
1000 MHz	dBm	dBm
2000 MHz	dBm	dBm
3000 MHz	dBm	dBm
4000 MHz	dBm	dBm
5000 MHz	dBm	dBm
6000 MHz	dBm	dBm
7000 MHz	dBm	dBm
8000 MHz	dBm	dBm
8999 MHz	dBm	dBm

Table A-19. Spectrum Analyzer Amplitude Accuracy Across Frequency – 10.1 MHz and 100 MHz

Freq (MHz)	Test Power (dBm)	Atten Level (dB)	Spec (dB)	Marker M1 Reading (dBm)	Dev (dB)	Freq (MHz)	Test Power (dBm)	Atten Level (dB)	Spec (dB)	Marker M1 Reading (dBm)	Dev (dB)
10.1	–30	0	±1.3			100	–30	0	±1.3		
	–30	5	±1.3				–30	5	±1.3		
	–30	10	±1.3				–30	10	±1.3		
	–30	20	±1.3				–30	20	±1.3		
	–2	30	±1.3				–2	30	±1.3		
	–2	40	±1.3				–2	40	±1.3		
	–2	50	±1.3				–2	50	±1.3		
	–2	60	±1.3				–2	60	±1.3		

Serial Number:	Firmware Revision:	Operator:
Options:		Date:

Spectrum Analyzer Amplitude Accuracy – MS2036C (continued)

Table A-20. Spectrum Analyzer Amplitude Accuracy Across Frequency – 500 MHz and 1000 MHz

Freq (MHz)	Test Power (dBm)	Atten Level (dB)	Spec (dB)	Marker M1 Reading (dBm)	Dev (dB)	Freq (MHz)	Test Power (dBm)	Atten Level (dB)	Spec (dB)	Marker M1 Reading (dBm)	Dev (dB)
500	-30	0	±1.3			1000	-30	0	±1.3		
	-30	5	±1.3				-30	5	±1.3		
	-30	10	±1.3				-30	10	±1.3		
	-30	20	±1.3				-30	20	±1.3		
	-2	30	±1.3				-2	30	±1.3		
	-2	40	±1.3				-2	40	±1.3		
	-2	50	±1.3				-2	50	±1.3		
	-2	60	±1.3				-2	60	±1.3		

Table A-21. Spectrum Analyzer Amplitude Accuracy Across Frequency – 2000 MHz and 3000 MHz

Freq (MHz)	Test Power (dBm)	Atten Level (dB)	Spec (dB)	Marker M1 Reading (dBm)	Dev (dB)	Freq (MHz)	Test Power (dBm)	Atten Level (dB)	Spec (dB)	Marker M1 Reading (dBm)	Dev (dB)
2000	-30	0	±1.3			3000	-30	0	±1.3		
	-30	5	±1.3				-30	5	±1.3		
	-30	10	±1.3				-30	10	±1.3		
	-30	20	±1.3				-30	20	±1.3		
	-2	30	±1.3				-2	30	±1.3		
	-2	40	±1.3				-2	40	±1.3		
	-2	50	±1.3				-2	50	±1.3		
	-2	60	±1.3				-2	60	±1.3		

Serial Number:	Firmware Revision:	Operator:
Options:		Date:

Spectrum Analyzer Amplitude Accuracy – MS2036C (continued)

Table A-22. Spectrum Analyzer Amplitude Accuracy Across Frequency – 4000 MHz and 5000 MHz

Freq (MHz)	Test Power (dBm)	Atten Level (dB)	Spec (dB)	Marker M1 Reading (dBm)	Dev (dB)	Freq (MHz)	Test Power (dBm)	Atten Level (dB)	Spec (dB)	Marker M1 Reading (dBm)	Dev (dB)
4000	-30	0	±1.3			5000	-30	0	±1.3		
	-30	5	±1.3				-30	5	±1.3		
	-30	10	±1.3				-30	10	±1.3		
	-30	20	±1.3				-30	20	±1.3		
	-2	30	±1.3				-2	30	±1.3		
	-2	40	±1.3				-2	40	±1.3		
	-2	50	±1.3				-2	50	±1.3		
	-2	60	±1.3				-2	60	±1.3		

Table A-23. Spectrum Analyzer Amplitude Accuracy Across Frequency – 6000 MHz and 7000 MHz

Freq (MHz)	Test Power (dBm)	Atten Level (dB)	Spec (dB)	Marker M1 Reading (dBm)	Dev (dB)	Freq (MHz)	Test Power (dBm)	Atten Level (dB)	Spec (dB)	Marker M1 Reading (dBm)	Dev (dB)
6000	-30	0	±1.3			7000	-30	0	±1.3		
	-30	5	±1.3				-30	5	±1.3		
	-30	10	±1.3				-30	10	±1.3		
	-30	20	±1.3				-30	20	±1.3		
	-2	30	±1.3				-2	30	±1.3		
	-2	40	±1.3				-2	40	±1.3		
	-2	50	±1.3				-2	50	±1.3		
	-2	60	±1.3				-2	60	±1.3		

Serial Number:	Firmware Revision:	Operator:
Options:		Date:

Spectrum Analyzer Amplitude Accuracy – MS2036C (continued)

Table A-24. Spectrum Analyzer Amplitude Accuracy Across Frequency – 8000 MHz and 8999 MHz

Freq (MHz)	Test Power (dBm)	Atten Level (dB)	Spec (dB)	Marker M1 Reading (dBm)	Dev (dB)	Freq (MHz)	Test Power (dBm)	Atten Level (dB)	Spec (dB)	Marker M1 Reading (dBm)	Dev (dB)
8000	-30	0	±1.3			8999	-30	0	±1.3		
	-30	5	±1.3				-30	5	±1.3		
	-30	10	±1.3				-30	10	±1.3		
	-30	20	±1.3				-30	20	±1.3		
	-2	30	±1.3				-2	30	±1.3		
	-2	40	±1.3				-2	40	±1.3		
	-2	50	±1.3				-2	50	±1.3		
	-2	60	±1.3				-2	60	±1.3		

Spectrum Analyzer Third Order Intercept – MS2036C

Table A-25. Spectrum Analyzer Third Order Intercept

Frequency	Specification	Marker Reading	Calculated TOI
2399.851 MHz		dBm	
2400.151 MHz		dBm	
2400 MHz	≥ +15 dBm		dBm

Serial Number:	Firmware Revision:	Operator:
Options:		Date:

A-5 MS2038C VNA Master Test Record

VNA Frequency Accuracy – MS2038C

Table A-26. VNA Frequency Accuracy

VNA Output Frequency	Specification	Frequency Counter Reading
2.6 GHz	± 3.9 kHz	kHz

VNA Transmission Dynamic Range – MS2038C

_____ Attached Test Data Report

VNA S-Parameter Measurements Verification – MS2038C

_____ Attached Verification Report

Serial Number:	Firmware Revision:	Operator:
Options:		Date:

Spectrum Analyzer Residual Spurious Response – MS2038C

Table A-27. Spectrum Analyzer Residual Spurious Response with Preamp Off

Start Freq	Stop Freq	RBW	VBW	Specification	Measured Values
9 kHz	100 kHz	300 Hz	10 Hz	≤ -90 dBm	dBm
100 kHz	10 MHz	300 Hz	100 Hz	≤ -90 dBm	dBm
10 MHz	2 GHz	30 kHz	3 kHz	≤ -90 dBm	dBm
2 GHz	4 GHz	10 kHz	1 kHz	≤ -90 dBm	dBm
4 GHz	5.35 GHz	10 kHz	300 Hz	≤ -90 dBm	dBm
5.35 GHz	7.2 GHz	3 kHz	300 Hz	≤ -90 dBm	dBm
7.2 GHz	8.2 GHz	3 kHz	300 Hz	≤ -90 dBm	dBm
8.2 GHz	9 GHz	3 kHz	300 Hz	≤ -90 dBm	dBm
9 GHz	10 GHz	1 kHz	100 Hz	≤ -90 dBm	dBm
10 GHz	11.1 GHz	300 Hz	100 Hz	≤ -90 dBm	dBm
11.1 GHz	13 GHz	1 kHz	100 Hz	≤ -90 dBm	dBm
13 GHz	16.5 GHz	1 kHz	100 Hz	≤ -85 dBm	dBm
16.5 GHz	17.5 GHz	300 Hz	30 Hz	≤ -85 dBm	dBm
17.5 GHz	18.5 GHz	300 Hz	30 Hz	≤ -85 dBm	dBm
18.5 GHz	19.25 GHz	300 Hz	30 Hz	≤ -85 dBm	dBm
19.25 GHz	20 GHz	300 Hz	30 Hz	≤ -85 dBm	dBm

Serial Number:	Firmware Revision:	Operator:
Options:		Date:

Spectrum Analyzer Residual Spurious Response – MS2038C (continued)

Table A-28. Spectrum Analyzer Residual Spurious Response with Preamp On

Start Freq	Stop Freq	RBW	VBW	Specification	Measured Values
1 MHz	10 MHz	3 kHz	300 Hz	≤ -100 dBm	dBm
10 MHz	2 GHz	30 kHz	3 kHz	≤ -100 dBm	dBm
2 GHz	4 GHz	30 kHz	3 kHz	≤ -100 dBm	dBm
4 GHz	5.35 GHz	30 kHz	3 kHz	≤ -100 dBm	dBm
5.35 GHz	7.2 GHz	30 kHz	1 kHz	≤ -100 dBm	dBm
7.2 GHz	9 GHz	30 kHz	3 kHz	≤ -100 dBm	dBm
9 GHz	11.1 GHz	10 kHz	1 kHz	≤ -100 dBm	dBm
11.1 GHz	13 GHz	30 kHz	3 kHz	≤ -100 dBm	dBm
13 GHz	16.2 GHz	30 kHz	3 kHz	≤ -100 dBm	dBm
16.2 GHz	18 GHz	3 kHz	300 Hz	≤ -100 dBm	dBm
18 GHz	18.8 GHz	10 kHz	1 kHz	≤ -100 dBm	dBm
18.8 GHz	20 GHz	3 kHz	300 Hz	≤ -100 dBm	dBm

Spectrum Analyzer Displayed Average Noise Level (DANL) – MS2038C

Table A-29. Spectrum Analyzer DANL with Preamp Off

Start Freq	Stop Freq	RBW	VBW	Specification	Measured Value (100 kHz RBW)	Calculated Value (1 Hz RBW)
10 MHz	4 GHz	100 kHz	1 kHz	≤ -141 dBm	dBm	dBm
4 GHz	9 GHz	100 kHz	1 kHz	≤ -134 dBm	dBm	dBm
9 GHz	13 GHz	100 kHz	1 kHz	≤ -129 dBm	dBm	dBm
13 GHz	20 GHz	100 kHz	1 kHz	≤ -123 dBm	dBm	dBm

Table A-30. Spectrum Analyzer DANL with Preamp On

Start Freq	Stop Freq	RBW	VBW	Specification	Measured Value (100 kHz RBW)	Calculated Value (1 Hz RBW)
10 MHz	4 GHz	100 kHz	1 kHz	≤ -160 dBm	dBm	dBm
4 GHz	9 GHz	100 kHz	1 kHz	≤ -156 dBm	dBm	dBm
9 GHz	13 GHz	100 kHz	1 kHz	≤ -152 dBm	dBm	dBm
13 GHz	20 GHz	100 kHz	1 kHz	≤ -145 dBm	dBm	dBm

Serial Number:	Firmware Revision:	Operator:
Options:		Date:

Spectrum Analyzer Frequency Accuracy – MS2038C

Table A-31. Spectrum Analyzer Frequency Accuracy

Frequency	Specification	Measured Value	Deviation
1 GHz	± 300 Hz	GHz	Hz
7 GHz	± 2.1 kHz	GHz	kHz

Spectrum Analyzer Frequency Accuracy (Option 31, GPS) – MS2038C

Table A-32. Spectrum Analyzer Frequency Accuracy with GPS On

Frequency	Specification	Measured Value	Deviation
7 GHz	$< \pm 350$ Hz	GHz	Hz

Spectrum Analyzer Single Side Band (SSB) Phase Noise – MS2038C

Table A-33. Spectrum Analyzer SSB Phase Noise

Offset Frequency	Specification	Measured Value	Calculated Value
10 kHz	≤ -100 dBc/Hz	dB	dBc/Hz
100 kHz	≤ -102 dBc/Hz	dB	dBc/Hz
1 MHz	≤ -107 dBc/Hz	dB	dBc/Hz
10 MHz	≤ -120 dBc/Hz	dB	dBc/Hz

Spectrum Analyzer Spurious Response (Second Harmonic Distortion) – MS2038C

Table A-34. Spectrum Analyzer Spurious Response (Second Harmonic Distortion)

Frequency	Specification	Measured Value	2nd Harmonic Level
50.1 MHz		dBm	
100.2 MHz	≤ -54 dBc	dBm	dBc

Serial Number:	Firmware Revision:	Operator:
Options:		Date:

Spectrum Analyzer Input Related Spurious (IRS) Signals – MS2038C

Table A-35. Spectrum Analyzer Input Related Spurious (IRS) Signals

Frequency	Specification	Measured Values	Calculated IRS
1000 MHz		dBm	
719 MHz to 721 MHz	≤ -60 dBc	dBm	dBc
3273 MHz		dBm	
2423 MHz to 3271 MHz	≤ -60 dBc	dBm	dBc
3275 MHz to 4123 MHz	≤ -60 dBc	dBm	dBc
8000 MHz		dBm	
7719 MHz to 7721 MHz	≤ -60 dBc	dBm	dBc
15000 MHz		dBm	
14719 MHz to 14721 MHz	≤ -60 dBc	dBm	dBc

Spectrum Analyzer Resolution Bandwidth Accuracy – MS2038C

Table A-36. Spectrum Analyzer Resolution Bandwidth Accuracy

RBW	Span	VBW	Lower Limit	Measured Values	Upper Limit
10 MHz	20 MHz	1 MHz	9 MHz	MHz	11 MHz
3 MHz	6 MHz	300 kHz	2.7 MHz	MHz	3.3 MHz
1 MHz	2 MHz	100 kHz	0.9 MHz	MHz	1.1 MHz
300 kHz	600 kHz	30 kHz	270 kHz	kHz	330 kHz
100 kHz	200 kHz	10 kHz	90 kHz	kHz	110 kHz
30 kHz	60 kHz	3 kHz	27 kHz	kHz	33 kHz
10 kHz	20 kHz	1 kHz	9 kHz	kHz	11 kHz
3 kHz	6 kHz	300 Hz	2.7 kHz	kHz	3.3 kHz
1 kHz	2 kHz	100 Hz	0.9 kHz	kHz	1.1 kHz
300 Hz	600 Hz	30 Hz	270 Hz	Hz	330 Hz
100 Hz	200 Hz	10 Hz	90 Hz	Hz	110 Hz
30 Hz	60 Hz	3 Hz	27 Hz	Hz	33 Hz
10 Hz	20 Hz	3 Hz	9 Hz	Hz	11 Hz
3 Hz	10 Hz	1 Hz	2.7 Hz	Hz	3.3 Hz
1 Hz	2 Hz	1 Hz	0.9 Hz	Hz	1.1 Hz

Serial Number:	Firmware Revision:	Operator:
Options:		Date:

Spectrum Analyzer Amplitude Accuracy – MS2038C

Note The listed Amplitude Accuracy specifications apply when the instrument is being verified in an environment between 20°C and 30°C after a 30 minute warm-up. For an instrument that is not being verified in a temperature controlled environment but within a temperature range between –10°C and 50°C and after a 60 minute warm-up, add ± 1 dB to the Amplitude Accuracy specification.

Table A-37. Spectrum Analyzer 50 MHz Amplitude Accuracy Setup Table

Test Power Level @ 50 MHz	Required Sensor B Reading
0 dBm	dBm
–4 dBm	dBm
–10 dBm	dBm
–14 dBm	dBm
–20 dBm	dBm
–24 dBm	dBm
–30 dBm	dBm
–34 dBm	dBm
–40 dBm	dBm
–44 dBm	dBm
–50 dBm	dBm

Table A-38. Spectrum Analyzer 50 MHz Amplitude Accuracy

Test Power	Specification	Reference Level	Atten Lvl	Measured Value	Deviation
0 dBm	±1.3 dB	10 dBm	30 dB	dBm	dB
–4 dBm	±1.3 dB	10 dBm	30 dB	dBm	dB
–10 dBm	±1.3 dB	0 dBm	20 dB	dBm	dB
–14 dBm	±1.3 dB	0 dBm	20 dB	dBm	dB
–20 dBm	±1.3 dB	–10 dBm	10 dB	dBm	dB
–24 dBm	±1.3 dB	–10 dBm	10 dB	dBm	dB
–30 dBm	±1.3 dB	–20 dBm	0 dB	dBm	dB
–34 dBm	±1.3 dB	–20 dBm	0 dB	dBm	dB
–40 dBm	±1.3 dB	–30 dBm	0 dB	dBm	dB
–44 dBm	±1.3 dB	–30 dBm	0 dB	dBm	dB
–50 dBm	±1.3 dB	–40 dBm	0 dB	dBm	dB

Serial Number:	Firmware Revision:	Operator:
Options:		Date:

Spectrum Analyzer Amplitude Accuracy – MS2038C (continued)

Table A-39. Spectrum Analyzer Amplitude Accuracy Across Frequency Setup Table

Frequency	Required Sensor B reading for –2 dBm @Attenuator output	Required Sensor B reading for –30 dBm @Attenuator output
10.1 MHz	dBm	dBm
100 MHz	dBm	dBm
500 MHz	dBm	dBm
1000 MHz	dBm	dBm
2000 MHz	dBm	dBm
3000 MHz	dBm	dBm
4000 MHz	dBm	dBm
5000 MHz	dBm	dBm
6000 MHz	dBm	dBm
7000 MHz	dBm	dBm
8000 MHz	dBm	dBm
9000 MHz	dBm	dBm
10000 MHz	dBm	dBm
11000 MHz	dBm	dBm
12000 MHz	dBm	dBm
13000 MHz	dBm	dBm
14000 MHz	dBm	dBm
15000 MHz	dBm	dBm
16000 MHz	dBm	dBm
17000 MHz	dBm	dBm
18000 MHz	dBm	dBm
19000 MHz (For Unit with Opt 11 Only)	dBm	dBm
19999 MHz (For Unit with Opt 11 Only)	dBm	dBm

Serial Number:	Firmware Revision:	Operator:
Options:		Date:

Spectrum Analyzer Amplitude Accuracy – MS2038C (continued)

Table A-40. Spectrum Analyzer Amplitude Accuracy Across Frequency – 10.0 MHz and 100 MHz

Freq (MHz)	Test Power (dBm)	Atten Level (dB)	Spec (dB)	Marker M1 Reading (dBm)	Dev (dB)	Freq (MHz)	Test Power (dBm)	Atten Level (dB)	Spec (dB)	Marker M1 Reading (dBm)	Dev (dB)
10.1	-30	0	±1.3			100	-30	0	±1.3		
	-30	5	±1.3				-30	5	±1.3		
	-30	10	±1.3				-30	10	±1.3		
	-30	20	±1.3				-30	20	±1.3		
	-2	30	±1.3				-2	30	±1.3		
	-2	40	±1.3				-2	40	±1.3		
	-2	50	±1.3				-2	50	±1.3		
	-2	60	±1.3				-2	60	±1.3		

Table A-41. Spectrum Analyzer Amplitude Accuracy Across Frequency – 500 MHz and 1000 MHz

Freq (MHz)	Test Power (dBm)	Atten Level (dB)	Spec (dB)	Marker M1 Reading (dBm)	Dev (dB)	Freq (MHz)	Test Power (dBm)	Atten Level (dB)	Spec (dB)	Marker M1 Reading (dBm)	Dev (dB)
500	-30	0	±1.3			1000	-30	0	±1.3		
	-30	5	±1.3				-30	5	±1.3		
	-30	10	±1.3				-30	10	±1.3		
	-30	20	±1.3				-30	20	±1.3		
	-2	30	±1.3				-2	30	±1.3		
	-2	40	±1.3				-2	40	±1.3		
	-2	50	±1.3				-2	50	±1.3		
	-2	60	±1.3				-2	60	±1.3		

Serial Number:	Firmware Revision:	Operator:
Options:		Date:

Spectrum Analyzer Amplitude Accuracy – MS2038C (continued)

Table A-42. Spectrum Analyzer Amplitude Accuracy Across Frequency – 2000 MHz and 3000 MHz

Freq (MHz)	Test Power (dBm)	Atten Level (dB)	Spec (dB)	Marker M1 Reading (dBm)	Dev (dB)	Freq (MHz)	Test Power (dBm)	Atten Level (dB)	Spec (dB)	Marker M1 Reading (dBm)	Dev (dB)
2000	-30	0	±1.3			3000	-30	0	±1.3		
	-30	5	±1.3				-30	5	±1.3		
	-30	10	±1.3				-30	10	±1.3		
	-30	20	±1.3				-30	20	±1.3		
	-2	30	±1.3				-2	30	±1.3		
	-2	40	±1.3				-2	40	±1.3		
	-2	50	±1.3				-2	50	±1.3		
	-2	60	±1.3				-2	60	±1.3		

Table A-43. Spectrum Analyzer Amplitude Accuracy Across Frequency – 4000 MHz and 5000 MHz

Freq (MHz)	Test Power (dBm)	Atten Level (dB)	Spec (dB)	Marker M1 Reading (dBm)	Dev (dB)	Freq (MHz)	Test Power (dBm)	Atten Level (dB)	Spec (dB)	Marker M1 Reading (dBm)	Dev (dB)
4000	-30	0	±1.3			5000	-30	0	±1.3		
	-30	5	±1.3				-30	5	±1.3		
	-30	10	±1.3				-30	10	±1.3		
	-30	20	±1.3				-30	20	±1.3		
	-2	30	±1.3				-2	30	±1.3		
	-2	40	±1.3				-2	40	±1.3		
	-2	50	±1.3				-2	50	±1.3		
	-2	60	±1.3				-2	60	±1.3		

Serial Number:	Firmware Revision:	Operator:
Options:		Date:

Spectrum Analyzer Amplitude Accuracy – MS2038C (continued)

Table A-44. Spectrum Analyzer Amplitude Accuracy Across Frequency – 6000 MHz and 7000 MHz

Freq (MHz)	Test Power (dBm)	Atten Level (dB)	Spec (dB)	Marker M1 Reading (dBm)	Dev (dB)	Freq (MHz)	Test Power (dBm)	Atten Level (dB)	Spec (dB)	Marker M1 Reading (dBm)	Dev (dB)
6000	-30	0	±1.3			7000	-30	0	±1.3		
	-30	5	±1.3				-30	5	±1.3		
	-30	10	±1.3				-30	10	±1.3		
	-30	20	±1.3				-30	20	±1.3		
	-2	30	±1.3				-2	30	±1.3		
	-2	40	±1.3				-2	40	±1.3		
	-2	50	±1.3				-2	50	±1.3		
	-2	60	±1.3				-2	60	±1.3		

Table A-45. Spectrum Analyzer Amplitude Accuracy Across Frequency – 8000 MHz and 9000 MHz

Freq (MHz)	Test Power (dBm)	Atten Level (dB)	Spec (dB)	Marker M1 Reading (dBm)	Dev (dB)	Freq (MHz)	Test Power (dBm)	Atten Level (dB)	Spec (dB)	Marker M1 Reading (dBm)	Dev (dB)
8000	-30	0	±1.3			9000	-30	0	±1.3		
	-30	5	±1.3				-30	5	±1.3		
	-30	10	±1.3				-30	10	±1.3		
	-30	20	±1.3				-30	20	±1.3		
	-2	30	±1.3				-2	30	±1.3		
	-2	40	±1.3				-2	40	±1.3		
	-2	50	±1.3				-2	50	±1.3		
	-2	60	±1.3				-2	60	±1.3		

Serial Number:	Firmware Revision:	Operator:
Options:		Date:

Spectrum Analyzer Amplitude Accuracy – MS2038C (continued)

Table A-46. Spectrum Analyzer Amplitude Accuracy Across Frequency – 10,000 MHz and 11,000 MHz

Freq (MHz)	Test Power (dBm)	Atten Level (dB)	Spec (dB)	Marker M1 Reading (dBm)	Dev (dB)	Freq (MHz)	Test Power (dBm)	Atten Level (dB)	Spec (dB)	Marker M1 Reading (dBm)	Dev (dB)
10000	-30	0	±1.3			11000	-30	0	±1.3		
	-30	5	±1.3				-30	5	±1.3		
	-30	10	±1.3				-30	10	±1.3		
	-30	20	±1.3				-30	20	±1.3		
	-2	30	±1.3				-2	30	±1.3		
	-2	40	±1.3				-2	40	±1.3		
	-2	50	±1.3				-2	50	±1.3		
	-2	60	±1.3				-2	60	±1.3		

Table A-47. Spectrum Analyzer Amplitude Accuracy Across Frequency – 12,000 MHz and 13,000 MHz

Freq (MHz)	Test Power (dBm)	Atten Level (dB)	Spec (dB)	Marker M1 Reading (dBm)	Dev (dB)	Freq (MHz)	Test Power (dBm)	Atten Level (dB)	Spec (dB)	Marker M1 Reading (dBm)	Dev (dB)
12000	-30	0	±1.3			13000	-30	0	±1.3		
	-30	5	±1.3				-30	5	±1.3		
	-30	10	±1.3				-30	10	±1.3		
	-30	20	±1.3				-30	20	±1.3		
	-2	30	±1.3				-2	30	±1.3		
	-2	40	±1.3				-2	40	±1.3		
	-2	50	±1.3				-2	50	±1.3		
	-2	60	±1.3				-2	60	±1.3		

Serial Number:	Firmware Revision:	Operator:
Options:		Date:

Spectrum Analyzer Amplitude Accuracy – MS2038C (continued)

Table A-48. Spectrum Analyzer Amplitude Accuracy Across Frequency – 14,000 MHz and 15,000 MHz

Freq (MHz)	Test Power (dBm)	Atten Level (dB)	Spec (dB)	Marker M1 Reading (dBm)	Dev (dB)	Freq (MHz)	Test Power (dBm)	Atten Level (dB)	Spec (dB)	Marker M1 Reading (dBm)	Dev (dB)
14000	-30	0	±2.3			15000	-30	0	±2.3		
	-30	5	±2.3				-30	5	±2.3		
	-30	10	±2.3				-30	10	±2.3		
	-30	20	±2.3				-30	20	±2.3		
	-2	30	±2.3				-2	30	±2.3		
	-2	40	±2.3				-2	40	±2.3		
	-2	50	±2.3				-2	50	±2.3		
	-2	60	±2.3				-2	60	±2.3		

Table A-49. Spectrum Analyzer Amplitude Accuracy Across Frequency – 16,000 MHz and 17,000 MHz

Freq (MHz)	Test Power (dBm)	Atten Level (dB)	Spec (dB)	Marker M1 Reading (dBm)	Dev (dB)	Freq (MHz)	Test Power (dBm)	Atten Level (dB)	Spec (dB)	Marker M1 Reading (dBm)	Dev (dB)
16000	-30	0	±2.3			17000	-30	0	±2.3		
	-30	5	±2.3				-30	5	±2.3		
	-30	10	±2.3				-30	10	±2.3		
	-30	20	±2.3				-30	20	±2.3		
	-2	30	±2.3				-2	30	±2.3		
	-2	40	±2.3				-2	40	±2.3		
	-2	50	±2.3				-2	50	±2.3		
	-2	60	±2.3				-2	60	±2.3		

Serial Number:	Firmware Revision:	Operator:
Options:		Date:

Spectrum Analyzer Amplitude Accuracy – MS2038C (continued)

Table A-50. Spectrum Analyzer Amplitude Accuracy Across Frequency – 18,000 MHz and 19,000 MHz

Freq (MHz)	Test Power (dBm)	Atten Level (dB)	Spec (dB)	Marker M1 Reading (dBm)	Dev (dB)	Freq (MHz)	Test Power (dBm)	Atten Level (dB)	Spec (dB)	Marker M1 Reading (dBm)	Dev (dB)
18000	-30	0	±2.3			19000 (For Unit with Opt 11 Only)	-30	0	±2.3		
	-30	5	±2.3				-30	5	±2.3		
	-30	10	±2.3				-30	10	±2.3		
	-30	20	±2.3				-30	20	±2.3		
	-2	30	±2.3				-2	30	±2.3		
	-2	40	±2.3				-2	40	±2.3		
	-2	50	±2.3				-2	50	±2.3		
	-2	60	±2.3				-2	60	±2.3		

Table A-51. Spectrum Analyzer Amplitude Accuracy Across Frequency – 19,999 MHz

Freq (MHz)	Test Power (dBm)	Atten Level (dB)	Spec (dB)	Marker M1 Reading (dBm)	Dev (dB)						
19999 (For Unit with Opt 11 Only)	-30	0	±2.3								
	-30	5	±2.3								
	-30	10	±2.3								
	-30	20	±2.3								
	-2	30	±2.3								
	-2	40	±2.3								
	-2	50	±2.3								
	-2	60	±2.3								

Serial Number:	Firmware Revision:	Operator:
Options:		Date:

Spectrum Analyzer Third Order Intercept – MS2038C

Table A-52. Spectrum Analyzer Third Order Intercept

Frequency	Specification	Marker Reading	Calculated TOI
2399.851 MHz		dBm	
2400.151 MHz		dBm	
2400 MHz	≥ +15 dBm		dBm

Appendix B — Test Fixture Schematics

B-1 Introduction

The following schematics are provided for those wishing to build their own test fixtures for the Option 10 verification test. The part numbers referenced in the schematics are Anritsu part numbers.

B-2 T2904 Test Fixture Schematic

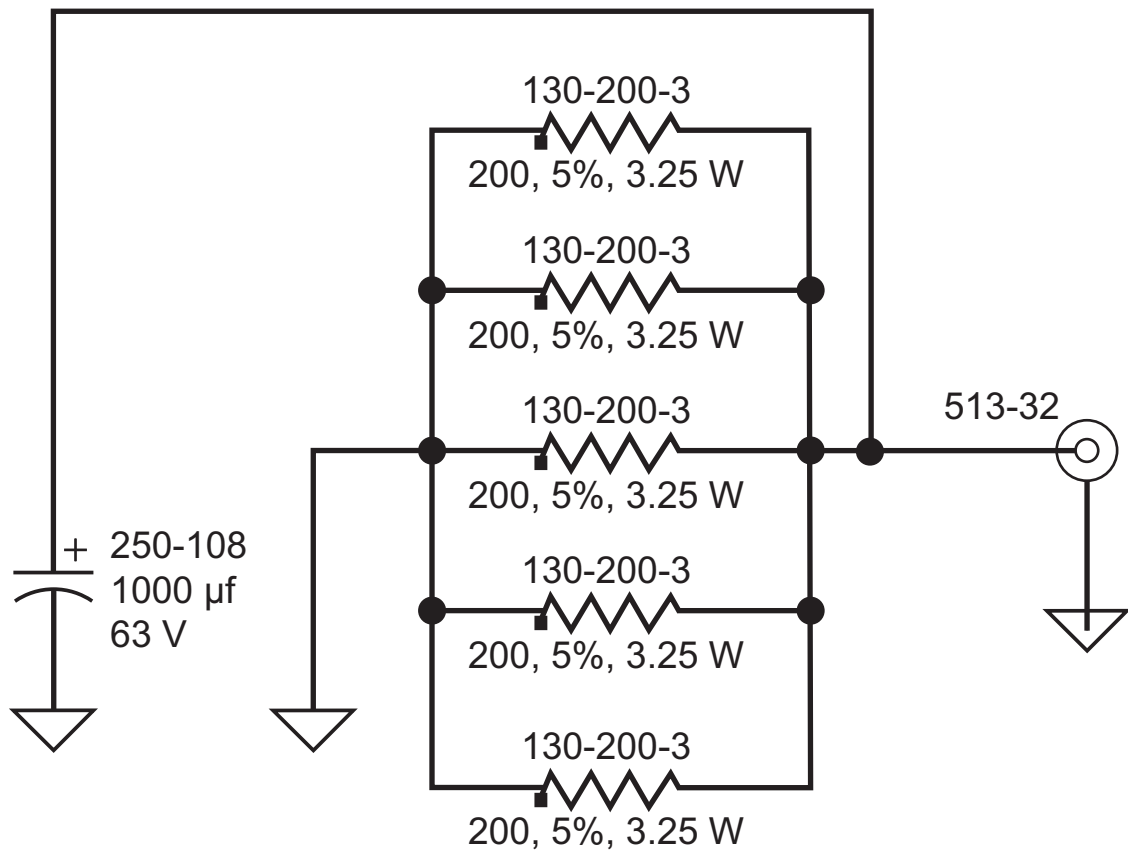

Figure B-1. T2904 Test Fixture Schematic

B-3 T3377 Test Fixture Schematic

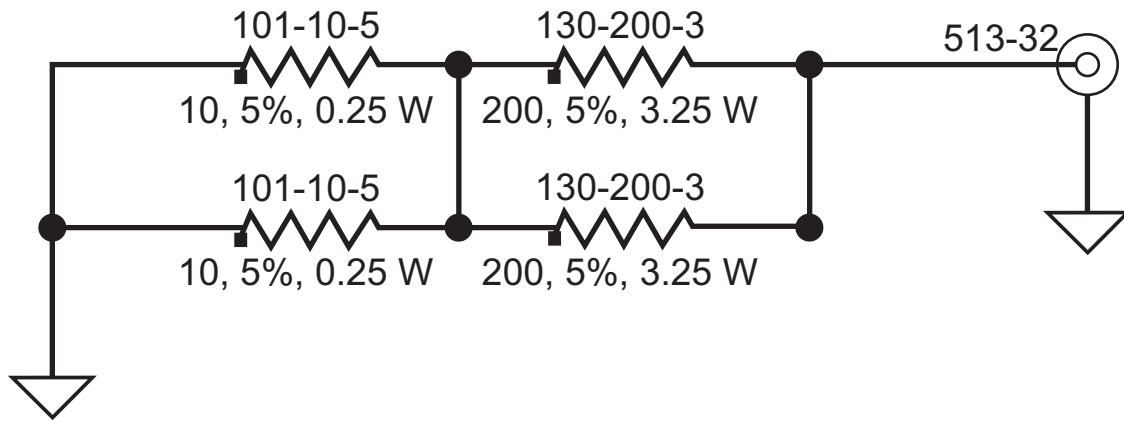

Figure B-2. T3377 Test Fixture Schematic

B-4 T3536 Test Fixture Schematic

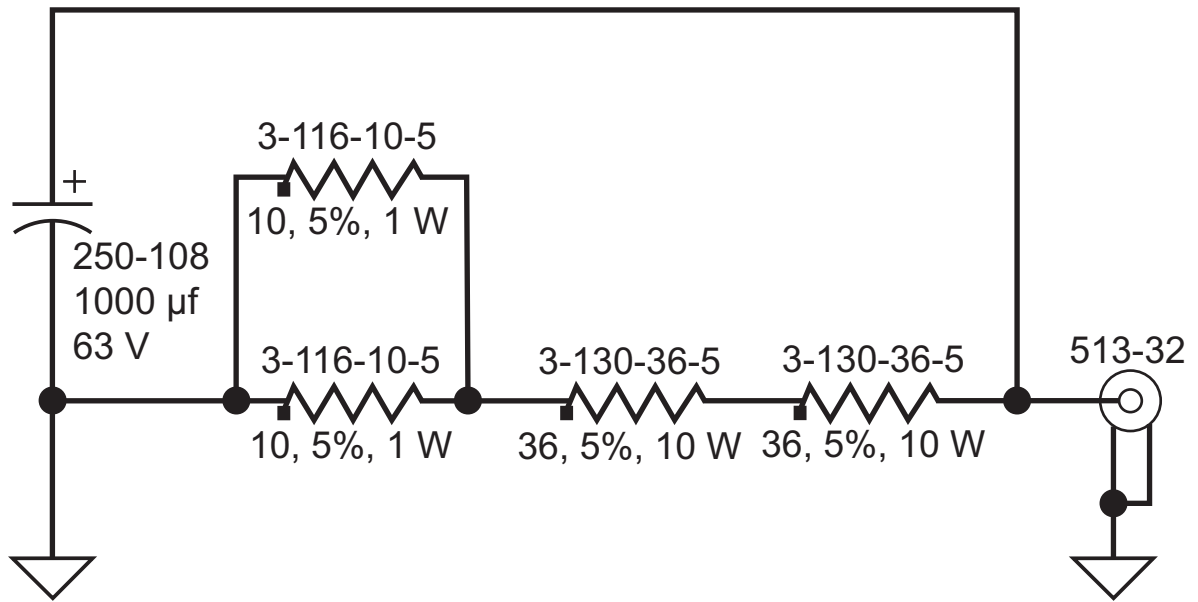

Figure B-3. T3536 Test Fixture Schematic

Index

- B**
- batteries
 - approved batteries only 5-1
 - battery access door 5-4
 - battery pack removal and replacement 5-3
 - care when analyzer not in use 5-2
 - completely discharged 8-1
 - contacts 5-7
 - disposal 5-2
 - disposal warning 5-2
 - physical handling 5-2
 - real time clock 6-1, 7-1
 - recharging 5-2
 - replaceable parts and assemblies 5-1
 - Beatty standard, VNA test 2-5
 - Bias Tee (Option 10)
 - fault test 4-5
 - Operational Check 4-4
 - Verification Specification 4-5
 - boot up
 - self test fails 8-2
 - turn-on problem 8-1
- C**
- cables
 - LCD backlight cable 6-46, 7-57, 7-60
 - case, opening 6-23, 7-25
 - cautions
 - cable routing during assembly 6-24, 7-27
 - cable routing to avoid pinching . 6-26, 6-34, 6-37, 6-38, . . 6-40, 6-41, 6-53, 7-39, 7-44, 7-48, 7-49, 7-67, 7-70, 7-75
 - connecting 10 MHz reference 3-6, 4-9
 - header pins, Power Monitor PCB 6-26
 - LCD display 6-15, 6-18
 - main keypad bezel holds speaker 6-13, 7-13, 7-19
 - maintaining test setup integrity 3-22
 - non-Anritsu test equipment 2-5
 - PCB for keypad 6-13, 6-19
 - ribbon cables for keypads 6-16, 6-19
 - speaker under main keypad bezel 6-13, 7-13, 7-19
 - use torque wrench 2-6
 - completely discharged battery 8-1
 - critical factors
 - S-parameter measurement verification 2-5
- D**
- disassembly sequence overview 6-10, 7-10
 - displayed average noise level
 - with preamp off 3-4
 - with preamp on 3-5
 - disposal of batteries 5-2
- E**
- drawings
 - MS2026C internal anatomy drawing 6-6
 - MS2028C internal anatomy drawing 6-8
 - MS202xC front panel parts drawing 6-2
 - MS202xC main keypad parts 6-4
 - MS2036C connections to SPA PCB 7-6
 - MS2036C internal anatomy drawing 7-5
 - MS2038C connections to SPA PCB 7-8
 - MS2038C internal anatomy drawing 7-7
 - MS203xC case and back screws 7-9
 - MS203xC front panel parts drawing 7-2
 - MS203xC main keypad parts 7-3
 - electrostatic discharge (ESD) 6-1, 7-1
- F**
- failure
 - VNA verification 2-7
 - fault test, Bias Tee 4-5
 - frequency accuracy test, VNA 2-1
 - front panel parts drawing
 - MS202xC 6-2
 - MS203xC 7-2
- G**
- GPS (Option 31)
 - GPS operational check test 4-6
- I**
- IF out of range message 8-2
 - install main PCB assembly 6-50, 7-62
 - internal anatomy drawing
 - MS2026C 6-6
 - MS2028C 6-8
 - MS2036C 7-5
 - MS2038C 7-7
- J**
- J2 keypad connector
 - removing Main Flex PCB 6-19
 - removing Main Keypad bezel 6-17
 - removing Main Keypad PCB 7-14
 - removing Main Menu Flex PCB 7-20
 - replacing Main Keypad PCB 6-14, 7-14
 - replacing Main Menu Flex PCB 7-21
 - shown in drawing for MS202xC 6-2
 - shown in drawing for MS203xC 7-2
- L**
- LCD backlight cable 6-46, 7-57, 7-60
 - lock error message 8-2
- M**
- MS2026C internal anatomy drawing 6-6
 - MS2028C internal anatomy drawing 6-8

MS202xC front panel parts drawing 6-2
 MS2036C internal anatomy drawing 7-5
 MS2038C internal anatomy drawing 7-7
 MS203xC front panel parts drawing 7-2

N

National Instruments VISA software 2-5
 No display, troubleshooting 8-1

O

open the VNA instrument case 6-23, 7-24
 opening the case 6-23, 7-25
 operating problems 8-2

P

PC software 2-5
 physical handling of batteries 5-2
 positive peak detection mode 3-1
 Power Monitor
 problems 8-2
 verification specifications 4-3
 preamp off
 DANL 3-4
 residual spurious response 3-1
 preamp on
 DANL 3-5
 residual spurious response 3-2
 precautions
 S-parameter measurement verification 2-6

R

real time clock (RTC) battery 6-1, 7-1
 reassemble instrument 6-50, 7-62
 recharging batteries 5-2
 removal and replacement
 battery pack 5-3
 remove
 Main PCB assembly 6-42, 7-50
 replace
 clear plastic LCD protector 6-49, 7-61
 GPS receiver module 6-35, 7-41
 hand strap handle 6-21, 7-22
 LCD display PCB assembly 6-48, 7-59
 Main PCB assembly 6-45, 7-56
 Power Monitor PCB 6-25
 rotary encoder 6-39, 7-45
 rotary knob 6-22, 7-23
 soft key keypad membrane 6-15, 7-16
 SPA module assembly 7-28
 VNA PCB assembly 6-28, 7-33
 residual spurious response
 preamp off 3-1
 preamp on 3-2
 SPA 3-1
 RMS/Avg detection mode 3-4

S

Safety Symbols
 General Symbols Safety-2
 In Manuals Safety-1
 On Equipment Safety-1
 self test fails 8-2
 SPA test
 positive peak detection mode 3-1
 residual spurious response 3-1
 S-parameter measurement verification
 critical factors 2-5
 precautions 2-6
 VNA 2-5
 S-Parameters
 measurements verification test 2-5
 specifications
 Bias Tee Verification 4-5
 Power Monitor verification 4-3

T

T2904 test fixture schematic B-1
 T3377 test fixture schematic B-2
 T3536 test fixture schematic B-3
 test fixture schematic
 T2904 B-1
 T3377 B-2
 T3536 B-3
 tests
 Bias Tee operational check 4-4
 frequency accuracy 2-1
 GPS (Option 31) operational check 4-6
 S-Parameter measurements verification 2-5
 transmission dynamic range test, VNA 2-3
 troubleshooting
 instrument boots with no display 8-1
 instrument cannot boot up 8-1
 instrument cannot complete boot-up 8-1

V

verification
 failure, VNA 2-7
 VISA software 2-5
 VNA test
 frequency accuracy 2-1
 S-parameter measurement verification 2-5
 transmission dynamic range 2-3
 voltage and current test 4-4

W

warm-up period 2-1
 warnings
 battery disposal 5-2
 electrostatic discharge (ESD) 6-1, 7-1

Anritsu



Anritsu prints on recycled paper with vegetable soybean oil ink.

Anritsu Company
490 Jarvis Drive
Morgan Hill, CA 95037-2809
USA
<http://www.anritsu.com>